

**LOS ANGELES COUNTY  
DEPARTMENT OF PUBLIC WORKS**

**HYDROLOGIC REPORT**

**1994-96**

PREPARED BY THE  
HYDRAULIC/WATER CONSERVATION DIVISION  
DECEMBER 1996

## TABLE OF CONTENTS

Credits .....	1
Introduction .....	2
The Los Angeles County .....	3
Flood Control and Water Conservation .....	7

### PRECIPITATION

General Discussion .....	A1
Los Angeles County Rainfall Indices (Oct. '94 through Sept. '96) .....	A3
Location Map of Rainfall Stations .....	PA1
Active Rainfall Stations .....	A5
Isohyetal Map (Jan. 4 & 5, 1995 Storm) .....	PA2
“ ” (Jan. 10, 1995 Storm) .....	PA3
“ ” (March 10-13, 1995 Storm) .....	PA4
“ ” (Total Rainfall 1994-1995 Storm Season) .....	PA5
“ ” (February 19-22, 1996 Storm) .....	PA6
“ ” (Total Rainfall 1995-1996 Storm Season) .....	PA7

### EVAPORATION

General Discussion/Evaporation Station List .....	B1
Summary of Monthly Evaporation Amounts at Selected Station .....	B2
Location Map of Evaporation Stations .....	PB1

### RUNOFF

General Discussion .....	C1
Location Map of Streamflow Recording Stations .....	PC1

Index of Stream Gaging Stations .....	C3
---------------------------------------	----

Summary of Monthly Discharge Records at Selected Stations

<u>STATION NO.</u>	<u>STATION NAME</u>	
L1-R	LITTLE ROCK CREEK above Little Rock Dam .....	C5
U7-R	FISH CREEK above Mouth of Canyon .....	C6
U8-R	SAN GABRIEL RIVER below Morris Dam .....	C7
F34D-R	LOS ANGELES RIVER below Firestone Boulevard .....	C8
F37B-R	COMPTON CREEK near Greenleaf Drive .....	C9
F38C-R	BALLONA CREEK above Sawtelle Boulevard .....	C10
F42B-R	SAN GABRIEL RIVER above Spring Street .....	C11
F45B-R	RIO HONDO above Stewart and Gray Road .....	C12
F64-R	RIO HONDO above Mission Bridge .....	C13
F81D-R	ALHAMBRA WASH near Klingerman Street .....	C14
F82C-R	RUBIO WASH at Glendon Wash .....	C15
F92C-R	SANTA CLARA RIVER below Highway 5 .....	C16
F122-R	PALLETT CREEK at Valyermo Highway .....	C17
F125-R	SANTIAGO CREEK above Little Rock Creek .....	C18
F130B-R	MALIBU CREEK below Cold Creek .....	C19
F181-R	MONTEBELLO STORM DRAIN above Rio Hondo .....	C20
F190-R	SAN GABRIEL RIVER at Foothill Boulevard .....	C21
F192B-R	RIO HONDO below Lower Azusa Road .....	C22
F193B-R	SANTA ANITA WASH at Longden Avenue .....	C23
F194B-R	SAWPIT WASH below Live Oak Avenue .....	C24

Summary of Monthly Discharge Records at Selected Stations (cont.)

<u>STATION NO.</u>	<u>STATION NAME</u>	
F250-R	SAN GABRIEL - AZUSA CONDUIT at 25 ft. Weir below San Gabriel Dam .....	C25
F252-R	VERDUGO WASH at Estelle Avenue .....	C26
F261C-R	SAN GABRIEL RIVER below Valley Boulevard .....	C27
F262C-R	SAN GABRIEL RIVER above Florence Avenue .....	C28
F263C-R	SAN GABRIEL RIVER below San Gabriel River Parkway .....	C29
F274B-R	DALTON WASH at Merced Avenue .....	C30
F280-R	SANTA FE CHANNEL below Santa Fe Dam .....	C31
E285-R	BURBANK - WESTERN STORM DRAIN at Riverside Drive .....	C32
F300-R	LOS ANGELES RIVER at Tujunga Avenue .....	C33
F304-R	WALNUT CREEK above Puente Avenue .....	C34
F312-R	SAN JOSE CHANNEL above Workman Mill Road .....	C35
F317-R	ARCADIA WASH below Grand Avenue .....	C36
F318-R	EATON WASH at Loftus Drive .....	C37
F319-R	LOS ANGELES RIVER below Wardlow Road .....	C38
F328-R	MINT CANYON CREEK at Fitch Avenue .....	C39
F329-R	BRADBURY CHANNEL below Central Avenue .....	C40
F338-R	RUBIO DIVERSION CHANNEL below Gooseberry Canyon Inlet .....	C41
F342-R	BRANFORD STREET CHANNEL below Sharp Avenue .....	C42
F354-R	COYOTE CREEK below Spring Street .....	C43
F377-R	BOUQUET CANYON CREEK at Urbandale Avenue .....	C44



## RESERVOIRS

General Discussion .....	D1
Location Map of District Reservoirs .....	PD1
<u>Dam Operation Records</u>	
BIG DALTON .....	D3
BIG TUJUNGA .....	D6
COGSWELL .....	D9
DEVIL'S GATE .....	D12
EATON WASH .....	D15
LIVE OAK .....	D18
MORRIS .....	D21
PACOIMA .....	D24
PUDDINGSTONE .....	D27
PUDDINGSTONE DIVERSION .....	D30
SAN DIMAS .....	D33
SAN GABRIEL .....	D36
SANTA ANITA .....	D39
SAWPIT .....	D42
THOMPSON CREEK .....	D45

## EROSION CONTROL

General Discussion .....	E1
Location Map of Debris Basins .....	PE1
Debris Basin-Design Data (1994-95 Storm Season) .....	E3

**EROSION CONTROL (cont.)**

Debris Basin-Debris Production History (1994-95 Storm Season) ..... E8

Debris Basin-Design Data (1995-96 Storm Season) ..... E11

Debris Basin-Debris Production History (1995-96 Storm Season) ..... E16

Burned Area Location Map (Oct. '94 through Sept. '95) ..... PE2

Burned Area Location Map (Oct. '95 through Sept. '96) ..... PE3

**WATER QUALITY**

General Discussion ..... F1

1994-95 Surface Water Quality Monitoring Locations ..... PF1

1995-96 Surface Water Quality Monitoring Locations ..... PF2

**WATER CONSERVATION**

General Discussion ..... G1

Data on Spreading Facilities owned by the Department ..... G9

Data on Spreading Facilities owned by Others ..... G13

Water Conserved in all Department Facilities (Water Year 1994-95) ..... G14

Imported and Reclaimed Water Spread Amounts (Water Year 1994-95) ..... G15

Water Conserved in all Department Facilities (Water Year 1995-96) ..... G16

Imported and Reclaimed Water Spread Amounts (Water Year 1995-96) ..... G17

Key Well Hydrographs (Listing and Locations) ..... G19

Location Map ..... PG1

West Coast ..... G21

Central Basin ..... G22/23/24

Main San Gabriel ..... G25/26

Key Well Hydrographs (Cont.)

San Gabriel Canyon .....	G27
Pomona .....	G28
Claremont Heights .....	G29
Raymond Basin .....	G30
Santa Clara Valley .....	G31
Antelope Valley .....	G32/33
Main San Fernando .....	G34/35
<u>Location Map of Water Conservation Facilities</u> .....	PG2
<u>Santa Clarita Valley Groundwater Basin</u> .....	PG3
<u>Groundwater Contour Maps</u>	
San Fernando Valley (Upper Los Angeles River Area-ULARA/W.Y. 1994-95) .....	PG4
San Fernando Valley (Upper Los Angeles River Area-ULARA/W.Y. 1995-96) .....	PG5
San Gabriel Valley (Water Year 1994-95) .....	PG6
San Gabriel Valley (Water Year 1995-96) .....	PG7
Coastal Plain (Water Year 1994-95) .....	PG8
Coastal Plain (Water Year 1995-96) .....	PG9
Santa Clarita Valley (Water Year 1994-95) .....	PG10
Santa Clarita Valley (Water Year 1995-96) .....	PG11

This report was prepared in the Hydraulic/Water Conservation Division under the direction of Robert D. Pedigo, Assistant Deputy Director. The following people contributed to the completion of this report:

**General Supervision and Coordination**

A. Gribnau

**Supervision**

T. Su

**Coordination**

S. Etman  
G. Farag  
J. Keith

**Collection and Computation**

M. Bonaparte	S. Morrison
R. Brown	M. Ramos
D. Carpenter	A. Rivera
S. Dagher	A. Rodriguez
J. Doughly	K. Smith
E. Esquerra	R. Sy
P. Gonda	R. Velez
A. Gotingo	I. Wong
H. Khachikian	D. Wilson
S. Khoo	

**Graphic Design, Layout, Art Production**

R. Brown  
J. Garcia  
J. Raccippio

## INTRODUCTION

This report contains hydrologic data relative to Los Angeles County for the period beginning October 1, 1994 and ending September 30, 1996. The data are presented in seven sections.

**Precipitation** - lists 284 active rainfall stations and presents corresponding seasonal rainfall amounts.

**Evaporation** - lists all locations for which evaporation data is on file and provides monthly evaporation amounts at 14 locations.

**Runoff** - presents the maximum, minimum, and mean of the daily flow rates for each month and the monthly volumes for 40 streamflow stations.

**Dam Operation** - presents the maximum and minimum of the daily inflow and outflow rates for each month, the instantaneous peak inflow and outflow rates and storage volumes for 15 dams and reservoirs.

**Erosion Control** - lists debris basins and debris production amounts.

**Water Quality Monitoring** - presents maps of surface and groundwater sampling locations.

**Conservation and Groundwater** - presents records of water conserved at various facilities, water injected at seawater barrier projects, well hydrographs, and Falls of 1994 and 1995 static groundwater contour maps.

Where practical, data which would satisfy immediate needs and serve as useful reference are published in these reports. Several tables lists locations for which unpublished data are available. Additional information may be obtained by writing to:

**Los Angeles County Department of Public Works  
Hydraulic/Water Conservation Division  
P.O. Box 1460  
Alhambra, CA 91802-1460**

or telephone: **(818) 458-6112**

## LOS ANGELES COUNTY

### TOPOGRAPHY

The County of Los Angeles covers an area of 4,083 square miles and measures approximately 66 miles in the east - west and 73 miles in the north - south directions.

The terrain within the County can be classified in broad terms as being 25 percent mountainous; 14 percent coastal plain; and 61 percent hills, valleys, or deserts. Relief of the terrain ranges from sea level to a maximum elevation of 10,000 feet. The coastal plain is generally of mild slope and contains relatively few depressions or natural ponding areas. The slopes of main river systems crossing the coastal plain, such as the San Gabriel River, Los Angeles River, and Ballona Creek, range from 4 to 14 feet per mile.

Topography in the mountainous area is generally rugged with deep, V-shaped canyons separated by sharp dividing ridges. Steep walled canyons with side slopes of 70 percent or more are common. The gradient of principal canyons in the San Gabriel Mountains ranges from 150 to 850 feet per mile. Mountain ranges are aligned in a general east-west direction with the dominant range being the San Gabriel Mountains. The majority of mountain ridges lie below Elevation 5,000 feet. The total area above this level is approximately 210 square miles.

### GEOLOGY - SOILS

Igneous, metamorphic, and sedimentary rock groups are all present within the County. The San Gabriel Mountains and Verdugo Hills are composed primarily of highly fractured igneous rock, with large areas of granitic rock formation being exposed. Faulting and deep weathering have produced porous zones in the rock formation; however, rock masses have produced a comparatively shallow soil mantle due to the steepness of slopes which accelerates erosion of the fine material.

Other mountains and hilly reaches are composed primarily of folded and faulted sedimentary rocks, including shale, sandstone, and conglomerate. Residual soils in these areas are shallow and generally less pervious than those of the San Gabriel Mountain range.

Valley and desert soils are alluvial and vary from coarse sand and gravel near canyon mouths to silty clay, clay and sand and gravel in lower valleys and the coastal plain. The alluvial fill has accumulated by repeated deposition of sediments to depths as great as several thousand feet. This fill is quite porous in areas of relatively low clay content. Geologic structures and irregularities in the underlying bedrock divide the alluvium into several groundwater basins. Valley soils are generally well drained but there are a few areas containing perched water.

### LAND USE

The principal vegetative cover of upper mountain areas consists of various species of brush and shrubs known as chaparral. Most trees found on mountain slopes are oak, with alder, willow, and sycamore found along streambeds at lower elevations. Pine, cedar, and juniper are found in ravines at higher elevations and along high mountain summits.

The chaparral is extremely flammable, and extensive burns of the mountain vegetation frequently occur during dry, low-humidity weather accompanied by high winds. Chaparral has the ability to sprout following fire and grows rapidly to re-establish the watershed cover within a period of 5 to 10 years.

Grasses are the principal natural vegetation on the hills. Much of the hill land and nearly all of the valley land in the densely populated portion of the County south of the San Gabriel Mountains has been converted to urban and suburban use. Development of the Santa Clarita Valley and desert areas to the north of the San Gabriel Mountains is sparse at present but is proceeding rapidly.

## **CLIMATE**

The climate within the County varies between subtropical on the Pacific Ocean side of the San Gabriel Mountain range to arid in the Mojave Desert. Nearly all precipitation occurs during the months of December through March. Precipitation during summer months is infrequent, and rainless periods of several months are common. Snowfall at elevations above 5,000 feet is frequently experienced during the winter storms, but the snow melts rapidly except on higher peaks and the northern slopes. Snow is rarely experienced on the coastal plain.

January and July are the coldest and warmest months of the year, respectively. At the Los Angeles civic center, the 30-year average daily minimum temperature for January is 48 degrees (Fahrenheit) above zero. The average daily maximum temperature for July is 84 degrees. At Mount Wilson (Elevation 5,850 feet), the 30-year average daily minimum temperature for January is 35 degrees above zero and the average daily maximum temperature for July is 80 degrees.

## **HYDROMETEOROLOGIC CHARACTERISTICS**

### Coastal and Mountain Areas

Precipitation in the Los Angeles area occurs primarily in the form of winter orographic rainfall associated with extra tropical cyclones of North Pacific origin. Major storms consist of one or more frontal systems and occasionally last four days or longer. Air masses and frontal systems associated with major storms commonly extend for 500 to 1,000 miles in length and produce rainfall simultaneously throughout the County. Major storms approach Southern California from the west or northwest with southerly winds which continue until frontal passage. The mountain ranges lie directly across the path of the inflow of warm, moist air, and orographic effects greatly intensify precipitation.

The seasonal normal rainfall in Los Angeles County ranges from 27.50 inches in the San Gabriel Mountains to 7.83 inches in the desert. The annual County average for the annual rainfall for Los Angeles County is 15.65 inches.

The effects of snowmelt upon flood runoff is of significance in the few cases when warm spring rains from southerly storms fall on a snowpack. During major storms, temperatures throughout the County may remain above freezing. Average individual storm rainfall amounts and intensities conform to a fairly definite aerial pattern which reflects general effects of topographic differences.

### Desert Areas

Summer convective rainfall is principally experienced in the upper San Gabriel Mountains and the Mojave Desert regions. In many desert areas, the most serious flooding occurs as a result of summer convective storms.

### **RUNOFF CHARACTERISTICS**

#### Mountain Areas

In mountain areas, the steep canyon slopes and channel gradients promote a rapid concentration of storm runoff. Depression storage and detention storage effects are minor in the rugged terrain. Soil moisture during a storm has a pronounced effect on runoff from the porous soils supporting a good growth of deep-rooted vegetation such as chaparral. Soil moisture deficiency is greatest at the beginning of a rainy season, having been depleted by the evapotranspiration process during the dry summer months. Precipitation during periods of soil moisture deficiency is nearly entirely absorbed by soils, and except for periods of extremely intense rainfall, significant runoff does not occur until soils are wetted to capacity. Due to high infiltration rates and porosity of mountain soils, runoff occurs primarily as subsurface flow or interflow in addition to direct runoff. Spring or base flow is essentially limited to portions of the San Gabriel Mountain range. Consequently, most streams in the County are intermittent.

Runoff from a mountain watershed recently denuded by fire exceeds that for the unburned state due to greatly increased quantities of inorganic debris present in the flow and increased direct runoff resulting from lowered infiltration rates. Debris production from a major storm has amounted to as much as 223,000 cubic yards per square mile of watershed. Boulders up to eight feet in diameter have been deposited in valley areas a considerable distance from their source.

Debris quantities equal in volume to storm runoff, representing a 100 percent bulking of runoff from a major storm, have been recorded. Where debris-laden flow traverses an alluvial fill unconfined by flood control works, flood discharges follow an unpredictable path across the debris cone formed at the canyon mouth.

#### Hill and Valley Areas

In hill areas, runoff concentrates rapidly from the generally steep slopes; however, runoff rates from undeveloped hill areas are normally smaller than those from mountain areas of the same size. In those hill areas which have been developed for residential use, concentration times become considerably decreased due to drainage improvement, and runoff volumes and rates have increased due to increased imperviousness. On the other hand, erosion is controlled and debris is minimized from storm flows. Debris production rates from undeveloped hill areas are normally smaller than those from mountain areas of the same size.

In highly developed valley areas, local runoff volumes have increased as the soil surface has become covered by impervious materials. Peak runoff rates for valley areas have also increased due to



elimination of natural ponding areas and improved hydraulic efficiency of water carriers such as streets and storm drain systems.

## **FLOOD CONTROL AND WATER CONSERVATION**

### **FLOODS. . .AN OLD STORY**

Floods in Los Angeles County have been recorded as far back as the days of the Mission Padres. For centuries waters have swept out of the San Gabriel Mountains causing extensive property damage and taking a great toll of lives.

Such a flood occurred in 1914 causing over \$10 million in property damage and taking many lives. As a result, the State legislature in 1915 enacted the statute creating the Los Angeles County Flood Control District. The responsibilities and authority vested in the Flood Control District were, in 1985, transferred to and are now part of the Los Angeles County Department of Public Works.

The Department, under the Flood Control Act, has two tasks. . .control the floods and conserve the water.

### **CONTROLLING THE WATERS**

Successful early bond issues financed construction of the 15 dams which the Department built in the San Gabriel Mountains and foothills to impound storm waters until they could be safely released. Debris basins were constructed to trap eroded materials which had caused terrible damage in the past. Flood channel improvements were undertaken to confine the waters and convey them safely through the urbanized areas to the ocean.

District engineers prepared a Comprehensive Plan in the early 1930's which would control flooding and save as much of the water as practicable when fully implemented.

Federal legislation in 1936 brought the United States Army Corps of Engineers into the local flood control picture. Since that time, the two agencies have been jointly pursuing implementation of the Comprehensive Plan. The Department also cooperates with the United States Natural Resources Conservation Service and Forest Service in erosion control.

### **CONSERVING THE WATERS**

In addition to its flood control program, the Department has the equally important mission of conserving as much of the storm and other waste waters as practicable. The use of water conservation facilities in or adjacent to river channels and their tributaries permits water to be percolated into groundwater reservoirs for later pumping and supply to consumers. These water conservation facilities are located in areas where the underlying soils are composed of porous sands and gravel formations. Some are shallow and resemble rice paddies, while others are deep basins which were once gravel pits.

The importance of this activity is apparent when it is realized that about 30 to 40 percent of the water used in the County is pumped from ground supplies. The growth of the County, combined with periodic droughts, seriously depleted these supplies on numerous occasions throughout the history of the County.

Other major conservation efforts by the Department include combatting the serious salt water intrusion into groundwater supplies inland from the Pacific Ocean and utilizing imported and reclaimed water to help replenish groundwater supplies.

**ORGANIZED TO DO THE JOB**

Day-to-day administration of Department affairs is vested in the Director of Public Works who is appointed by and responsible to the Los Angeles County Board of Supervisors. A part of the Department's activities involve the planning, design and construction of flood control and water conservation facilities, and the operation and maintenance of dams, debris basins, spreading grounds, channels, and storm drains.

# **PRECIPITATION**

## **PRECIPITATION**

This section contains annual precipitation data collected by the Department for the period beginning October 1, 1994 and ending September 30, 1996. Although the Department operates and maintains 271 rainfall stations, including 199 standard and 72 automatic gages which record amounts for durations ranging from 5 minutes to 24 hours, only annual amounts for the report period are listed herein. Additional data can be obtained by contacting the custodian of hydrologic records at the location shown in the front of the report.

### **RAINFALL AMOUNTS**

For 1994-95 water year, the rainfall recorded at the downtown Los Angeles station (No. 716) reached 27.43 inches, or 177 percent of the station's long-term average of 15.51 inches. The Cogswell Dam station (No. 334B) recorded 58.85 inches for the year which is 179 percent of the station's long-term average of 32.88 inches.

During this reporting period, Los Angeles County experienced a series of severe winter storms that brought heavy rainfall throughout the County resulting in localized flood damages, personal injury, and three deaths.

The first severe storm started on January 3, 1995 afternoon and intensified the next day. Raingage No. 415 which is located at Signal Hill and Carson, recorded 6.4 inches during the 24-hour period started 3:45 P.M. on January 4, 1995, which is all time maximum rainfall intensity ever recorded at this station and exceeded the 100-year event. The January 4th storm was severe in the southern County area, lesser rainfall and intensities in the northern areas. Isohyetal map for this storm is shown on page PA2.

The second severe storm moved into the County on January 10, 1995. The 24-hour period rainfall intensities in the Malibu area for this storm were consistent 5- to 10-year rainfall events, and those in most of the other parts of the county were consistent with 2- to 5-year rainfall events. Isohyetal map for this storm is shown on page PA3.

The third powerful Pacific storm began on March 10, 1995 and continued through March 11 bringing with 5- to 25-year rainfall events to the County. Isohyetal map for this storm is shown on page PA4.

For the 1995-96 Water Year, the rainfall recorded at the downtown Los Angeles station (No. 716) reached 13.23 inches, or 85 percent of the station's long term average. The Cogswell Dam station (No. 334B) recorded 26.40 inches for the year which is 80 percent of the station's long term average.

The 1995-96 Water Year was very dry until February 1996. The isohyetal map for the February 19 - 22 1996 is shown on page PA6.

### **ALERT SYSTEM (AUTOMATIC LOCAL EVALUATION IN REAL TIME)**

The Department of Public Works has installed a state-of-the-art ALERT computer system to monitor meteorological conditions in the County and Southern California in real time, i.e., as they occur. The system includes a network of field sensors that monitor precipitation amounts.

During the report period, the Department has continued to install and expand its ALERT System. The Department's ALERT System is also now automatically receiving rainfall data from the Corps of Engineers' Los Angeles Telemetry System.

#### **COOPERATION**

The cooperation of observers in furnishing rainfall data to the Department as a public service is appreciated. The effort of the many agencies and individuals who have so freely cooperated with us in the collection of this data have resulted in the large number of complete records for the period covered by this report.

Data from 22 stations of the Departments records are reported and published by the National Oceanic and Atmospheric Administration (NOAA).

**LOS ANGELES COUNTY RAINFALL INDICES  
USING SELECTED STATIONS FOR THE PERIOD  
OCTOBER 1, 1994 THROUGH SEPTEMBER 30, 1996**

	PERCENT OF AREA	SEASONAL NORMAL PRECIP. (inches)	94-95		95-96	
			TOTAL PRECIP. TO DATE	PERCENT OF SEASONAL NORMAL	TOTAL PRECIP. TO DATE	PERCENT OF SEASONAL NORMAL
A. COASTAL PLAIN	14.10	13.71	25.19	184	11.38	83
B. SAN FERNANDO VALLEY	7.90	17.62	35.01	199	13.22	75
C. SAN GABRIEL VALLEY	7.50	17.64	29.61	168	14.35	81
D. SAN GABRIEL MTS.	13.40	27.50	44.78	163	23.56	86
E. LITTLE ROCK, BIG ROCK	4.50	18.61	30.80	166	12.77	69
F. SANTA MONICA MTS.	5.70	19.96	40.14	201	14.81	74
G. SANTA CLARA	18.90	16.64	28.17	169	11.05	66
H. DESERT	28.00	7.83	13.35	170	4.65	59
<b>COUNTY</b>	<b>100.00</b>	<b>15.65</b>	<b>27.27</b>	<b>174</b>	<b>11.69</b>	<b>75</b>
LOS ANGELES (STATION #716)		15.51	27.43	177	13.23	85
COGSWELL DAM (STATION #334B)		32.88	58.85	179	25.15	81

MAX., MIN. & NORMAL CURVES

LOS ANGELES (STATION #716)  
SEASONAL NORMAL PRECIPITATION - 15.51"

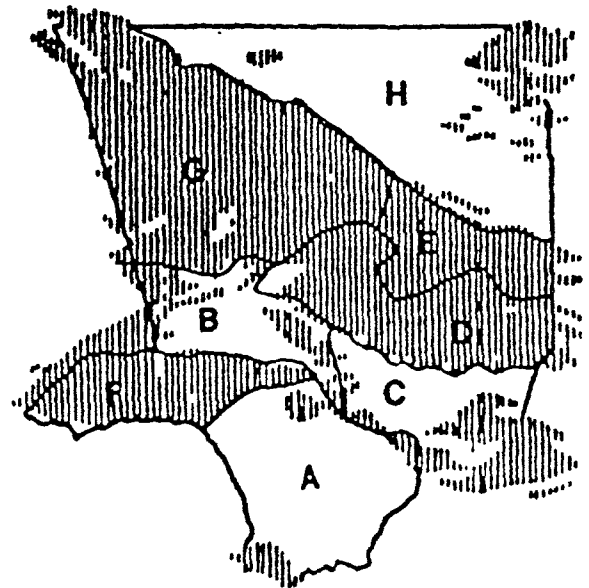
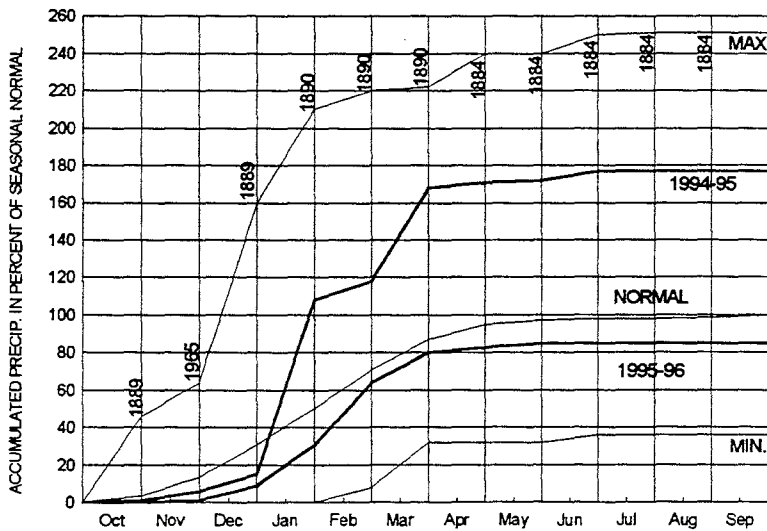





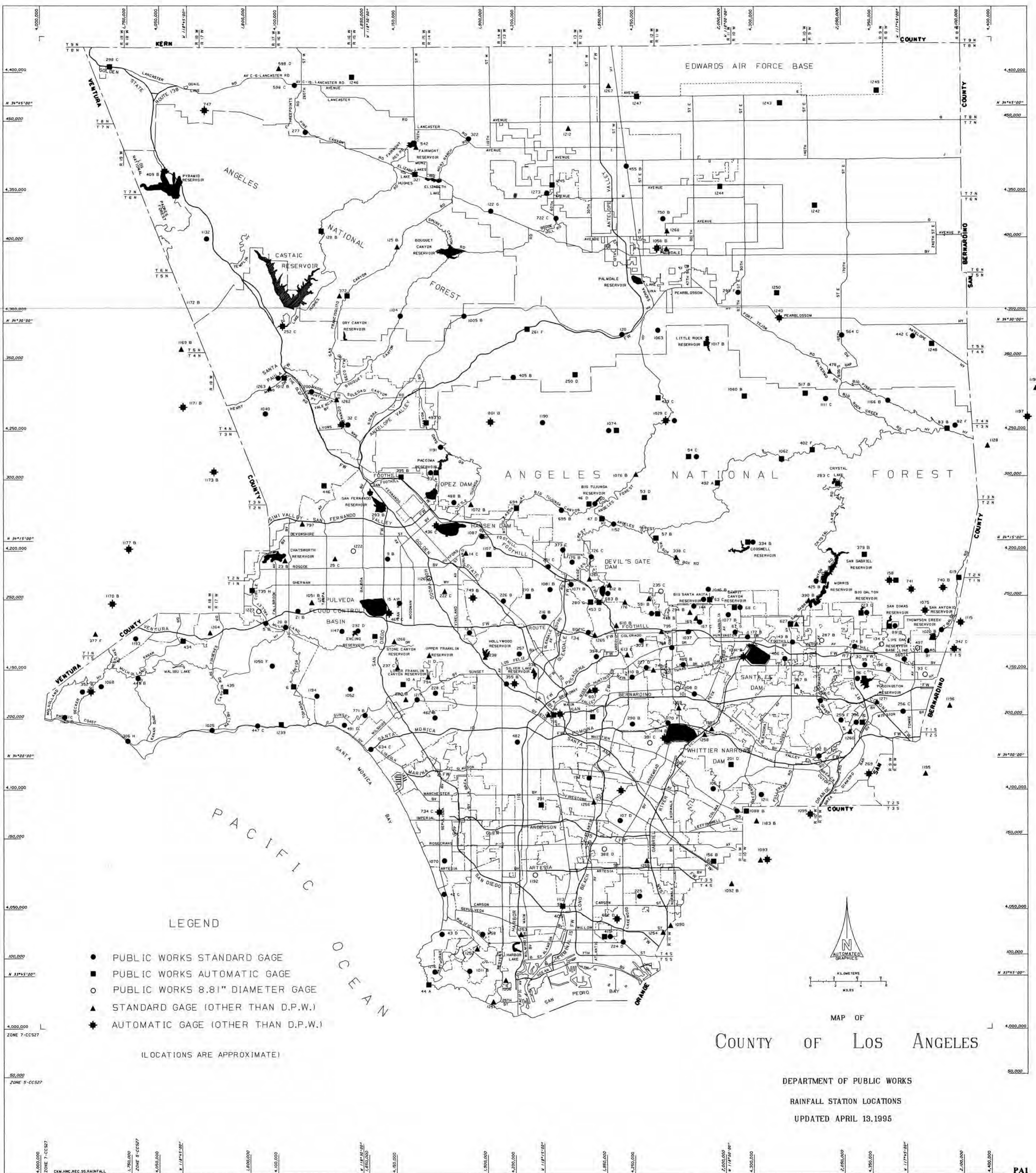

LEGEND

- PUBLIC WORKS STANDARD GAGE
- PUBLIC WORKS AUTOMATIC GAGE
- PUBLIC WORKS 8.81" DIAMETER GAGE
- ▲ STANDARD GAGE (OTHER THAN D.P.W.)
- ✱ AUTOMATIC GAGE (OTHER THAN D.P.W.)

(LOCATIONS ARE APPROXIMATE)



MAP OF  
COUNTY OF LOS ANGELES

DEPARTMENT OF PUBLIC WORKS  
RAINFALL STATION LOCATIONS  
UPDATED APRIL 13, 1995



## Active Rainfall Stations During Water Years 1994-95 And 1995-96

Station No.	Station Name	Type of Gage	Thomas Guide Page	North Latitude	West Longitude	Gage Elev. (Feet)	Seasonal 94-95 Total (Inches)	Seasonal 95-96 Total (Inches)
5B	CALABASAS	S	100 F3	34-09-24	118-38-14	924	33.06	11.01
6	TOPANGA PATROL STATION	A	590 A7	34-05-03	118-35-57	745	47.43	18.90
9B	SEPULVEDA AND RAYEN	S	531 H1	34-13-52	118-28-04	828	29.61	10.42
10A	BEL AIR HOTEL	A	592 B7	34-05-11	118-26-45	540	38.08	13.50
11D	UPPER FRANKLIN CYN RES.	SP	592 F2	34-07-10	118-24-35	867	31.25 †	12.18
13C	NORTH HOLLYWOOD-LAKESIDE	S	563 B5	34-08-46	118-21-13	550	41.31	12.19
14C	ROSCOE-MERRILL	S	503 B6	34-14-19	118-21-32	1050	27.50	10.28
15A	VAN NUYS	S	561 G1	34-10-48	118-27-03	695	33.48	10.47 †
17	SEPULVEDA CYN AT MULHOLLAND	A	561 E7	34-07-51	118-29-26	1425	44.45	15.60
20B	GIRARD RESERVOIR	S	559 J4	34-09-07	118-36-36	986	35.97	10.59
21B	WOODLAND HILLS	S	560 A2	34-10-14	118-35-33	875	28.44	9.98
23B	CHATSWORTH RESERVOIR	SP AP	529 G1	34-13-44	118-37-18	900	26.61	12.20
25C	NORTHRIDGE-L.A.D.W.P.	SP	530 H1	34-13-52	118-32-28	810	26.04	10.61
32C	NEWHALL-SOLEDAD DIV. HDQTRS	AP S	4550 J7	34-23-07	118-31-54	1243	29.94	9.31
33A	PACOIMA DAM	S A	4642 F7	34-19-48	118-23-59	1500	33.82	15.18
42C	REDONDO BEACH-CITY HALL	S	762 G5	33-50-43	118-23-20	70	23.89	10.95
43D	PALOS VERDES ESTATES	S	792 H4	33-47-58	118-23-29	216	25.88	8.92
44A	POINT VICENTE LIGHTHOUSE	A	822 F5	33-44-30	118-24-38	125	23.25	8.50
46D	BIG TUJUNGA DAM	S A	4725 C6	34-17-40	118-11-14	2315	44.64	20.43
47D	CLEAR CREEK-CITY SCHOOL	A	505 F1	34-16-38	118-10-12	3150	51.90	28.10
53D	COLBYS	A	4726 C4	34-18-05	118-06-39	3620	44.71	21.90
54C	LOOMIS RANCH-ALDER CREEK	S A	4557	34-20-55	118-02-54	4325	28.61	11.32
57B	CAMP HI HILL (OPIDS)	A	506	34-15-18	118-05-41	4250	69.90	31.10
63C	SANTA ANITA DAM	S A	537 E2	34-11-03	118-01-12	1400	50.88	29.41
67G	MONROVIA-MOUNTAIN AVENUE	S	567 J4	34-08-46	117-59-05	602	35.49	19.11
68C	SAWPIT DAM	S A	537 J7	34-10-30	117-59-07	1375	47.67	29.29
82F	TABLE MOUNTAIN	S	4561 G6	34-22-56	117-40-39	7420	26.78	11.87
83B	BIG PINES RECREATION PARK	A	4561 F6	34-22-44	117-41-20	6860	37.50	17.50
89B	SAN DIMAS DAM	S A	570 F2	34-09-10	117-46-17	1350	39.31	21.73
91	CLAREMONT-INDIAN HILL	S	571 C7	34-07-22	117-43-11	1403	27.97	17.00 †
93C	CLAREMONT-POLICE STATION	8.81	601 C3	34-05-45	117-43-18	1170	26.52	14.91
95	SAN DIMAS-FIRE WARDEN	S	600 B3	34-06-26	117-48-19	955	28.26	14.46
96C	PUDDINGSTONE DAM	S A	600 B4	34-05-31	117-48-24	1030	29.41	15.89
102D	WALNUT-N.J. INDUSTRIES	S	679 E3	34-00-11	117-52-10	500	28.73	12.02
106F	WHITTIER CITY YARD	S	677 B5	33-58-57	118-02-50	300	22.05	12.06
107D	DOWNEY-FIRE DEPARTMENT	S	705 J7	33-55-48	118-08-47	110	26.82	10.68
108D	EL MONTE FIRE STATION	S	597 C7	34-04-30	118-02-30	275	28.25	15.07
109D	WEST ARCADIA	S	566 G7	34-07-42	118-04-22	547	34.45	18.02
110B	ALHAMBRA	S	569 A4	34-05-40	118-07-41	533	32.02	16.22
120	VINCENT PATROL STATION	S	4375 H6	34-29-17	118-08-27	3135	14.06	5.18
125B	SAN FRANCISQUITO CYN P.H. 1	SP	X	34-35-25	118-27-15	2105	26.76	14.40
128B	ELIZABETH LAKE	A	X	34-36-28	118-33-40	2075	36.20	15.60
134C	PUDDINGSTONE DIVERSION	8.81	570 F5	34-07-52	117-46-55	1160	30.67	17.84
143B	AZUSA-CITY PARK	S	568 J5	34-08-03	117-54-17	610	33.55	18.95
144	SIERRA MADRE DAM	S	537 B4	34-10-34	118-02-32	1100	46.85	28.64
156B	LA MIRADA-STANDARD OIL CO.	A	737 F5	33-52-59	118-01-00	75	24.20	10.60
158	TANBARK FLATS	AP A	X	34-12-20	117-45-40	2750	47.60 †	26.10 †
167C	ARCADIA PUMPING PLANT #1	S	567 D2	34-09-31	118-02-02	611	36.60	20.80
169	SIERRA MADRE PUMPING PLANT	SP	567 B2	34-09-47	118-02-21	700	41.44	24.71
170F	POTRERO HEIGHTS	S	636 H5	34-02-32	118-04-44	285	31.68	14.83 †
172B	DUARTE	S	568 C4	34-08-26	117-58-02	548	31.28	17.27
174B	GLENDORA	S	570 A6	34-07-43	117-49-08	930	30.88	18.48
175B	LA CANADA IRRIGATION DIS.	S	535 A1	34-13-39	118-12-40	2020	47.27	20.87

## Active Rainfall Stations During Water Years 1994-95 And 1995-96

Station No.	Station Name	Type of Gage	Thomas Guide Page	North Latitude	West Longitude	Gage Elev. (Feet)	Seasonal 94-95 Total (Inches)	Seasonal 95-96 Total (Inches)
176	ALTADENA-RUBIO CANYON	SP	536 A1	34-10-55	118-08-15	1125	35.39	16.72
191C	L.A.C.D.P.W.-WAREHOUSE	A	635 B1	34-03-48	118-11-58	400	31.80	15.04
192C	BELL-FIRE STATION	8.81	675 D7	33-58-45	118-11-16	145	27.41 †	12.50 †
193C	COVINA-NIGG	S	599 D5	34-04-55	117-52-25	575	30.19	15.93
196C	LA VERNE-FIRE STATION	S	600 G2	34-06-06	117-46-20	1050	29.34	13.09
200	SAUGUS-S. C. EDISON CO.	S	4550 C2	34-25-21	118-34-26	1096	23.00 †	10.20 †
201D	HACIENDA HEIGHTS	A	677 J4	33-59-40	117-59-28	875	32.70	16.40
210C	BRAND PARK	A	534 C6	34-11-18	118-16-20	1250	33.80	15.70
216B	GLENDALE-ANDREE	S	564 F2	34-09-54	118-15-01	615	33.38	13.56
222C	NORTH HOLLYWOOD P. P.	SP	532 G5	34-11-39	118-23-17	717	31.78 †	10.65 †
223C	BIG DALTON DAM	S A	570 B1	34-10-06	117-48-36	1587	45.78	25.66
224D	LONG BEACH-ALAMITOS LAND CO.	S	796 A5	33-46-42	118-08-04	45	24.37 †	9.30 †
225	MONTANA RANCH-LAKEWOOD	S	766 C4	33-50-35	118-07-09	47	23.82	12.87
226B	BURBANK-FIRE STATION	S	533 H7	34-10-58	118-18-23	680	34.95 †	11.15
227D	SAN GABRIEL-BRUNGTON-ORTON	S	596 D2	34-06-18	118-06-32	472	34.45	17.19
228C	BEVERLY HILLS CITY HALL	AP S	632 G1	34-06-00	118-23-40	245	31.60	13.60 †
235C	HENNIGER FLATS	A 8.81	536 F5	34-11-38	118-05-17	2550	45.44	22.64
237C	STONE CANYON RESERVOIR	SP	591 J3	34-06-21	118-27-13	865	43.60	14.32
238	HOLLYWOOD DAM	SP	593 F2	34-07-04	118-19-55	750	31.86	13.06
250D	ACTON CAMP	A	4465 A5	34-27-02	118-11-55	2625	16.90	6.30
251C	LA CRESCENTA	S	534 F1	34-13-20	118-14-40	1440	42.91	19.76
252C	CASTAIC DAM	SP AP	4369	34-29-53	118-36-53	1150	24.90	10.18
255F	MT. SAN ANTONIO COLLEGE	S	639 J4	34-02-41	117-50-19	720	25.83	12.70
256C	POMONA-FIRE STATION	S	640 J2	34-03-16	117-45-10	844	27.09 †	13.20 †
261F	ACTON-ESCONDIDO CANYON	A	4374 B6	34-29-42	118-16-22	2960	17.50	8.60
269D	DIAMOND BAR FIRE STATION	SP AP	680 B2	33-59-50	117-48-55	870	30.72	14.99
277	SAWMILL MOUNTAIN	S	X	34-43-15	118-35-00	3700	41.84	13.66
280C	FLINTRIDGE-SACRED HEART	A	535 E7	34-10-54	118-11-08	1600	44.20	20.00
283C	CRYSTAL LAKE-EAST PINE FLAT	A	4651	34-19-02	117-50-28	5370	65.20	29.80
287B	GLENDDORA-CITY HALL	8.81	569 E5	34-08-09	117-51-52	785	38.22	20.39
290B	MONTEREY PARK-FIRE STATION	S	636 A5	34-02-27	118-07-42	305	31.20	16.91
291	LOS ANGELES-96th AND CENTRAL	A	704 E5	33-56-56	118-15-17	121	28.00	12.90
292D	ENCINO RESERVOIR	S A	561 B4	34-08-56	118-30-57	1075	37.86	8.58
293B	LAKE LOS ANGELES	SP	481 E5	34-17-18	118-28-54	1150	32.43	13.80
294B	SIERRA MADRE-MIRA MONTE P.P.	SP	567 A1	34-10-11	118-02-51	985	46.20	26.99
298C	GORMAN - SHERIFF	A	X	34-47-47	118-51-27	3835	29.30	6.00
299F	LITTLE ROCK - SCHWAB	S	4287 H7	34-32-12	117-58-43	2800	9.50 †	4.04
303F	PASADENA - CALTECH	S	566 B6	34-08-14	118-07-25	800	37.26 †	18.52
306H	ZUMA BEACH	S	667 B1	34-01-15	118-49-42	15	31.37	13.12
321	PINE CANYON PATROL STATION	A	4102 C3	34-40-24	118-25-45	3286	33.60	7.50
322	MUNZ VALLEY RANCH	S	4013 A4	34-42-50	118-21-15	2600	20.78	5.92
334B	COGSWELL DAM	S A	XI	34-14-37	117-57-35	2300	58.57	25.37
336	SILVER LAKE RESERVOIR	SP	594 C4	34-06-08	118-15-54	445	27.78	12.19
338C	MT. WILSON-OBSERVATORY	SP	537 A1	34-14-07	118-04-28	5709	61.80	34.32
342C	UPLAND-CHAPPEL	AP	571 G6	34-07-33	117-40-52	1610	30.74	16.88
352B	LECHUZA PATROL STATION	AP S	626 F2	34-04-38	118-52-47	1620	40.03	18.99
355B	LOS ANGELES CITY COLLEGE	AP S	594 A5	34-05-14	118-17-28	310	28.31 †	12.04
356C	SPADRA-LANTERMAN HOSPITAL	S A	640 B4	34-02-31	117-48-35	690	27.29	12.96
372	SAN FRANCISQUITO P. H. NO.2	SP A	X	34-32-02	118-31-27	1580	19.60	8.10
373C	BRIGGS TERRACE	S A	504 H6	34-14-17	118-13-27	2200	42.59	22.03 †
377F	LAKE SHERWOOD ESTATES	SP AP	557 A4	34-08-26	118-52-31	960	38.20	14.15 †
379B	SAN GABRIEL-EAST FORK	A	510	34-14-09	117-48-18	1600	45.93	26.20
387B	COVINA CITY YARD	SP	599 B5	34-05-02	117-53-57	508	28.41	14.30

## Active Rainfall Stations During Water Years 1994-95 And 1995-96

Station No.	Station Name	Type of Gage	Thomas Guide Page	North Latitude	West Longitude	Gage Elev. (Feet)	Seasonal 94-95 Total (Inches)	Seasonal 95-96 Total (Inches)
388D	PARAMOUNT-COUNTY FIRE DEPT.	8.81	735 G4	33-53-50	118-10-02	80	31.58	14.56
390B	MORRIS DAM	SP	539	34-10-53	117-52-43	1210	45.20	26.02
391C	MONTEBELLO-FIRE DEPARTMENT	8.81	676 E2	34-01-08	118-06-15	250	27.13	11.37
394	HIGHLAND PARK	S	595 E1	34-07-06	118-10-39	620	30.51	14.36
395B	OLIVE VIEW SANITARIUM	A	481 J1	34-19-29	118-26-55	1425	36.30	17.10
402F	CEDAR SPRINGS	A	XI	34-21-21	117-52-34	6780	55.40	28.40
405B	SOLEDAD CANYON	S	4463 J6	34-26-23	118-17-33	2150	21.72	9.76 †
406C	WEST AZUSA	S	598 H2	34-06-53	117-54-56	505	28.98	14.00
409B	PYRAMID RESERVOIR	SP AP	X	34-40-34	118-46-47	2505	31.81	6.71
415	SIGNAL HILL-CITY HALL	S A	795 G3	33-47-49	118-10-03	140	24.37	9.31
423C	ANGELES FOREST-ALISO CYN	A	XI	34-24-57	118-05-26	3920	30.10	12.80
425B	SAN GABRIEL DAM	S A	509	34-12-19	117-51-38	1481	50.16	28.22
434	AGOURA	A	558 B7	34-08-08	118-45-08	800	35.70	11.00
435	MONTE NIDO	A	628 J1	34-04-41	118-41-35	600	45.50	17.90
436C	HANSEN DAM	AP	502 G3	34-16-08	118-23-59	1110	26.80	8.85
442C	MESCAL CREEK	S	XI	34-29-05	117-44-10	3570	10.31	4.61
443B	LATIGO CANYON-BEACH RANCH	S	587 D6	34-05-35	118-48-52	1700	51.46	19.65
446	ALISO CANYON-OAT MOUNTAIN	A	480 F3	34-18-53	118-33-25	2367	42.40	22.90
447C	CARBON CANYON	S	629 F6	34-02-18	118-38-56	50	26.34 †	12.23 †
449B	EATON WASH DAM	S A	566 E1	34-10-06	118-05-33	880	37.08	18.00
453D	DEVILS GATE DAM	A	535 E7	34-10-53	118-10-27	980	29.78	19.90
455B	LANCASTER-HWY MAINTENANCE	S	4105 J1	34-40-57	118-08-02	2395	10.85	4.34
462B	HILLCREST COUNTRY CLUB	S	632 F4	34-02-54	118-24-06	185	31.23	13.63
465C	SEPULVEDA DAM	AP	561 G2	34-10-06	118-28-11	683	33.84 †	9.39
480B	TEMPLE CITY FIRE STATION	S	597 A2	34-06-31	118-03-25	404	34.70 †	9.11 †
482	LOS ANGELES-U.S.C.	S	674 A1	34-01-14	118-17-15	208	23.05	12.27
488B	KAGEL CANYON PATROL STATION	S	482 D5	34-17-45	118-22-30	1450	31.62 †	14.18 †
491D	PACIFIC PALISADES	S	630 J6	34-02-22	118-31-43	293	34.05	12.00 †
492A	CHILAO-HWY MAINTENANCE STA.	A	4557	34-19-05	118-00-30	5275	38.80	15.80
493D	SAND CANYON-MACMILLAN RANCH	A	4552 D7	34-23-17	118-24-50	1805	42.26	18.70
497	CLAREMONT-SLAUGHTER	8.81	571 B7	34-07-35	117-43-55	1350	31.29	17.44
517B	LEWIS RANCH	A	XI	34-25-12	117-53-11	4615	27.50	9.40
542	FAIRMONT	SP	X	34-42-15	118-25-40	3050	27.62	9.12
560A	LA VERNE HEIGHTS	S	640 A1	34-06-48	117-45-02	1210	30.04	16.60
564C	LLANO	S	4379 F5	34-29-13	117-50-02	3390	10.09	5.00 †
591B	SANTA ANITA RESERVOIR	SP	536 E7	34-11-08	118-06-16	1205	39.90	19.01
598C	NEENACH-ERSTAD	S	X	34-46-28	118-35-55	3062	21.91	3.82
598D	NEENACH-CHECK 43-D.W.R.	SP	X	34-47-40	118-37-15	2965	21.34	3.95
610B	PASADENA-CITY HALL	SP	27 A4	34-08-54	118-08-36	864	36.51	16.59
612B	PASADENA-CHLORINE PLANT	SP	535 F3	34-12-04	118-09-49	1160	42.32	19.52
613C	PASADENA FIRE STATION	SP	566 A6	34-07-15	118-08-05	779	35.86	15.16
619	SAN ANTONIO CYN-SIERRA P. H.	A	XI	34-12-29	117-40-26	3110	48.10	29.30
627	SAN GABRIEL CANYON-P. H.	SP A	568 J3	34-09-20	117-54-28	744	42.72	22.69
634C	SANTA MONICA	S	671 E2	34-00-43	118-29-27	94	26.86	10.20
662D	LONG BEACH AIRPORT	SP	791 J1	33-49-00	118-09-00	34	20.56	9.90
680B	WESTWOOD (U.C.L.A.)	SP	632 B1	34-04-10	118-26-30	430	35.36	13.61
683B	SUNSET RIDGE	S A	535 F5	34-12-53	118-08-47	2110	43.38	21.44
694G	BIG TUJUNGA CANYON-CAMP 15	A	X	34-17-22	118-17-17	1525	31.20	14.40
695B	TUJUNGA CANYON-VOGEL FLAT	S	X	34-17-12	118-13-32	1850	51.77	22.92
716	LOS ANGELES-DUCOMMUN ST.	SP A AP	634 H4	34-03-09	118-14-13	306	27.50	13.23
722C	BELLEVUE	S	4194 F1	34-37-23	118-13-55	2880	13.50 †	5.00 †
726C	ANGELES CREST GUARD STATION	S	X	34-14-01	118-11-04	2300	53.98	25.70 †
734C	L. A. INTERNATIONAL AIRPORT	SP AP	702 G5	33-56-25	118-23-44	105	22.86	10.23

## Active Rainfall Stations During Water Years 1994-95 And 1995-96

Station No.	Station Name	Type of Gage	Thomas Guide Page	North Latitude	West Longitude	Gage Elev. (Feet)	Seasonal 94-95 Total (Inches)	Seasonal 95-96 Total (Inches)
735H	BELL CANYON	A	529 D6	34-11-40	118-39-23	895	31.80	12.70
740B	SAN DIMAS CANYON-FERN NO.2	AP	IX	34-11-48	117-41-45	5200	48.10 †	24.00 †
741	SAN DIMAS CYN	AP	IX	34-11-41	117-44-26	2675	45.93 †	23.00 †
742C	SAN GABRIEL FIRE DEPARTMENT	SP	596 F4	34-06-11	118-05-56	445	28.88	16.03
747	SANDBERG-AIRWAYS STATION	SP AP	X	34-44-47	118-43-29	4517	25.72 †	6.06
749B	BURBANK VALLEY PUMP PLANT	SP AP	533 C6	34-11-11	118-20-54	655	31.78	11.57
750B	PALMDALE REGIONAL AIRPORT	S	4196 E5	34-37-20	118-05-00	2528	9.28	4.22
771B	PACIFIC PALISADES-RIVIERA	S	631 D5	34-03-03	118-29-58	315	44.20 †	13.00 †
794	LOWER FRANKLIN RESERVOIR	SP	592 F6	34-05-43	118-24-40	585	33.92	12.60
795	PASADENA-JOURDAN	SP	566 F5	34-08-52	118-05-14	705	33.43	17.30
797	DE SOTO RESERVOIR	SP	500 B2	34-16-17	118-35-12	1127	32.38	14.03
801B	MAGIC MOUNTAIN	AP	X	34-23-18	118-19-27	4720	46.68 †	22.78
802C	EAGLE ROCK RESERVOIR	SP	565 C5	34-08-47	118-11-20	970	29.15	13.49
807	ASCOT RESERVOIR	SP AP	595 C6	34-04-46	118-11-14	620	29.68	14.13
1005B	MINT CANYON FIRE STATION	S	X	34-30-35	118-21-40	2300	17.32	10.77 †
1006	SAN PEDRO-CITY RESERVOIR	SP A	824 B4	33-44-37	118-17-47	150	21.57	9.91
1011B	PALOS VERDES FIRE STATION	S	823 D3	33-45-25	118-21-11	1275	25.24	12.47 †
1012B	CASTAIC JUNCTION	S A	4459 H7	34-26-18	118-36-43	1005	23.00 †	10.24 †
1017B	LITTLE ROCK CREEK ABOVE DAM	A	XI	34-28-41	118-01-24	3280	15.70	5.80
1020B	PADUA HILLS PATROL STATION	S	571 F3	34-08-52	117-41-55	1800	33.17	19.05
1025	MALIBU BEACH-DUNNE	S	628 G7	34-02-00	118-42-42	160	20.95	12.02
1029C	TUJUNGA-MILL CREEK SUMMIT	AP S	X	34-23-22	118-04-49	4990	33.59	16.13
1037	ARCADIA-ARBORETUM	S	567 A5	34-08-48	118-02-59	565	33.71	19.48
1041B	SANTA FE DAM	AP	598 A1	34-07-04	117-58-24	427	31.80	17.08
1046B	SANTA ANITA CYN-CHANNY FLAT	S	537 E1	34-11-46	118-01-20	2175	63.52	37.67
1050F	OLD TOPANGA CANYON	S	589 G5	34-06-24	118-37-43	1000	52.19	15.67
1051B	CANOGA PARK-PIERCE COLLEGE	SP	530 D7	34-10-51	118-34-23	800	30.21	10.45
1058B	PALMDALE	SP AP	4196 D6	34-35-17	118-05-31	2595	9.19	3.95
1060B	LITTLE ROCK-SYCAMORE CAMP	A	XI	34-25-02	117-58-13	4000	19.60	10.60
1062	BUCKHORN FLAT	A	XI	34-20-44	117-55-08	6760	55.85 †	22.00 †
1063	SOLEDAD PASS	S	4376 D6	34-29-35	118-05-28	3520	15.86	6.27
1068	RATTLESNAKE CANYON	S	586 G7	34-05-00	118-51-55	1290	40.55 †	19.00 †
1070	MANHATTAN BEACH	S	732 J6	33-53-00	118-23-19	182	22.71	9.06
1071B	DESCANSO GARDENS	S	535 B2	34-12-07	118-12-46	1325	42.44	19.06
1072B	LITTLE TUJUNGA RANGER STA.	SP A	4723 A5	34-17-37	118-21-38	1275	31.41	14.60
1074	LITTLE GLEASON	A	X	34-22-43	118-08-57	5600	17.96	7.81
1075	UPPER WOLFSKILL	AP	571 C1	34-10-13	117-43-16	3625	52.42 †	24.00 †
1076B	MONTE CRISTO RANGER STATION	SP	XI	34-19-42	118-07-20	3360	33.09	15.44
1077B	MONROVIA-FIVE POINTS	S	567 G1	34-09-58	117-59-37	962	42.96	25.50
1081B	GLENDALE-GREGG	SP	534 F5	34-11-45	118-14-30	1350	42.44	18.76
1087	GREEN-VERDUGO PUMPING PLANT	S	503 D4	34-15-25	118-20-11	1340	29.28	11.94
1088B	LA HABRA HEIGHTS	S A	708 D3	33-56-55	117-57-51	445	29.04	11.52
1090	LOS ALAMITOS	SP	796 J1	33-48-35	118-04-35	25	25.10 †	11.90 †
1092B	BUENA PARK	3"P	OC10 C1	33-51-28	117-59-29	80	24.90 †	12.00 †
1093	FULLERTON AIRPORT	SP AP	738 A7	33-52-23	117-58-24	100	24.20 †	12.00 †
1095	ORANGE COUNTY RESERVOIR	SP AP	OC 2 F4	33-56-07	117-52-58	660	27.14	12.07
1104	BOUQUET CANYON AT TEXAS CYN	S	X	34-30-35	118-27-00	1760	18.21 †	11.80 †
1107D	LA TUNA DEBRIS BASIN	A	503 E6	34-14-13	118-19-37	1160	31.35	12.60
1111C	DEVILS PUNCHBOWL	S	XI	34-24-48	117-51-25	4760	33.35 †	11.00 †
1113	DOMINGUEZ WATER CO.	A	764 J6	33-49-54	118-13-30	30	26.70	10.50 †
1114B	WHITTIER NARROWS DAM	AP	636 H7	34-01-29	118-05-02	239	26.90	15.84
1115	SAN ANTONIO DAM	AP SP	571 J2	34-09-24	117-40-20	2120	41.12	19.90
1126A	LOS ANGELES-EAST VALLEY	8.81	532 E4	34-12-30	118-24-35	780	30.92	9.85



## Active Rainfall Stations During Water Years 1994-95 And 1995-96

Station No.	Station Name	Type of Gage	Thomas Guide Page	North Latitude	West Longitude	Gage Elev. (Feet)	Seasonal 94-95 Total (Inches)	Seasonal 95-96 Total (Inches)
1128	WRIGHTWOOD FIRE DEPARTMENT	SP	S.B.CO.	34-21-34	117-37-57	5960	24.50	10.80
1129B	NICHOLAS CANYON	S	626 A6	34-02-52	118-54-57	340	24.86	14.33
1132	OAK FLAT GUARD STATION	S	X	34-35-56	118-43-15	2800	36.91 †	14.20 †
1140	ROSEMEAD	8.81	597 C6	34-04-53	118-03-55	305	28.40	16.02
1147	EL CABALLERO COUNTRY CLUB	S	560 J6	34-08-52	118-31-53	1000	33.24	7.78
1152	CLEAR CREEK RANGER STATION	S	XI	34-16-15	118-09-11	3625	48.67 †	24.67
1158	TORRANCE MUNICIPAL AIRPORT	S	793 E4	33-47-59	118-20-08	102	28.46	8.86
1166B	MILE HIGH RANCH	S	XI	34-24-40	117-46-15	5280	20.91	6.45
1169B	PIRU-TEMESCAL GUARD STATION	SP	V.CO.	34-28-22	118-45-21	1150	37.21	16.51
1170B	THOUSAND OAKS WEATHER STA.	AP	V.CO.	34-10-44	118-51-01	805	32.39	11.72
1171B	CAMULOS RANCH	SP AP	V.CO.	34-24-22	118-45-21	725	30.61	12.99
1172B	PIRU CANYON ABOVE PIRU LAKE	AP	V.CO.	34-30-48	118-45-24	1120	38.40	14.02
1173B	TAPO CANYON	AP	V.CO.	34-19-54	118-42-39	1525	28.89	16.70
1177B	BARD RESERVOIR	AP	V.CO.	34-14-32	118-49-41	1010	26.11	11.62
1183B	LA HABRA FIRE STATION	3P	708 D5	33-55-53	117-57-17	315	28.90 †	12.00 †
1190	PACOIMA CYN-NORTH FORK	S	XI	34-23-17	118-15-06	4180	49.59 †	15.00 †
1191	BEAR DIVIDE	S	128 F6	34-21-35	118-23-37	2700	44.64	22.05
1192	CARSON FIRE STATION	8.81	764 E1	33-52-04	118-15-45	92	23.14	9.99
1193	WESTLAKE VILLAGE	S	557 C7	34-08-19	118-49-05	885	38.02 †	11.00 †
1194	SANTA YNEZ RESERVOIR	S	630 E1	34-04-23	118-33-59	735	39.41	16.88
1195	CHINO FIRE STATION NO. 2	SP	S.B.CO.	33-59-00	117-43-20	655	29.90	13.44
1196	MONTCLAIR FIRE DEPARTMENT	SP	641 H1	34-03-41	117-41-16	965	25.07	13.43
1197	CAJON WEST SUMMIT	SP	S.B.CO.	34-23-30	117-34-35	4838	16.80	6.15
1198	PHELAN FIRE CONTROL	SP	S.B.CO.	34-25-30	117-34-00	4160	8.56	8.16
1211	HACIENDA GOLF CLUB	S	O.CO.	33-57-40	117-56-57	750	31.67 †	12.00 †
1212	LANCASTER FSS/FAA	SP	4014 G1	34-44-00	118-13-00	2340	8.46	3.00
1216	RANCHO PALOS VERDES	S	822 H3	33-45-10	118-23-32	780	20.56	10.74
1217	LOS ANGELES COUNTRY CLUB	S	632 D2	34-04-10	118-25-17	380	34.02	14.93
1222	NORTHRIDGE-GARLAND	8.81	501 C4	34-14-17	118-30-59	911	27.51	10.75
1223	WOODLAND HILLS-SHERMAN	8.81	559 E2	34-10-06	118-38-57	1035	29.63	10.55
1239	MALIBU-BIG ROCK MESA	A	629 H6	34-02-34	118-37-16	725	34.80	15.50
1240	PEARBLOSSOM-CALIF.D.W.R.	SP AP	4378 F3	34-30-32	117-55-15	3050	9.36	4.48
1242	ROCKY BUTTES	A	XI	34-39-00	117-51-48	2540	5.80	3.20
1243	REDMAN	A	XI	34-45-52	117-55-30	2360	8.60	3.70
1244	LANCASTER-ROPER	A	4107 D1	34-40-27	118-00-37	2450	6.60	3.20
1245	QUARTZ HILL-HALL	A	4104 F2	34-40-28	118-14-40	2395	13.50	4.70
1246	SCOTT RANCH	A	XI	34-46-59	118-28-10	2710	18.90	2.50
1247	NORTH LANCASTER	A	3926 B4	34-45-41	118-07-30	2310	9.00	3.70
1248	MESCAL-SMITH	A	XI	34-28-03	117-42-40	3810	10.53	5.38
1249	RELAY	A	XI	34-45-43	117-47-55	3140	9.10	4.50
1250	AVEK	A	4288 F7	34-32-21	117-55-23	2825	9.15 †	3.70
1251	PALOS VERDES-WHITES POINT	SP	853 H2	33-42-50	118-19-02	100	15.50 †	8.00 †
1252	PALOS VERDES LANDFILL	SP	793 D6	33-45-40	118-20-03	400	29.00 †	11.00 †
1253	CARSON-COUNTY SANITATION	SP	794 C4	33-48-07	118-16-58	40	25.50 †	9.50 †
1254	LONG BEACH RECLAMATION PLANT	SP	796 G2	33-48-11	118-05-20	20	24.84	11.00 †
1255	LOS COYOTES RECLAMATION	SP	736 E6	33-53-05	118-06-24	70	22.98	12.00 †
1256	SOUTH GATE TRANSFER STATION	SP	705 G4	33-56-40	118-09-56	100	22.90 †	11.80 †
1257	SAN JOSE CREEK RECLAMATION	SP	637 F5	34-01-55	118-01-16	275	27.76	14.55 †
1258	PUENTE HILLS LANDFILL	SP	637 D6	34-01-35	118-01-49	300	25.80 †	15.33 †
1259	WHITTIER NARROWS RECLAMATION	SP	636 J1	34-03-59	118-03-54	225	24.45	14.61 †
1260	SPADRA LANDFILL	SP	640 A4	34-02-36	117-49-50	700	26.95 †	13.34 †
1261	LA CANADA RECLAMATION PLANT	SP	535 D2	34-13-00	118-11-14	1800	44.25	20.30 †
1262	SAUGUS RECLAMATION PLANT	SP	4550 G4	34-24-48	118-32-23	1150	22.34	7.28 †

## Active Rainfall Stations During Water Years 1994-95 And 1995-96

Station No.	Station Name	Type of Gage	Thomas Guide Page	North Latitude	West Longitude	Gage Elev. (Feet)	Seasonal 94-95 Total (Inches)	Seasonal 95-96 Total (Inches)
1263	VALENCIA RECLAMATION PLANT	SP	4549 G1	34-25-55	118-37-13	1000	20.82	8.50 †
1264	CALABASAS LANDFILL	SP	558 G5	34-08-25	118-42-35	800	32.10 †	11.90 †
1265	SCHOLL CANYON LANDFILL	SP	565 C5	34-08-38	118-11-07	1000	30.20 †	15.30 †
1266	MISSION CANYON LANDFILL	SP	591 G1	34-08-40	118-28-45	1150	30.90 †	10.00 †
1267	LANCASTER RECLAMATION PLANT	SP	3925 D2	34-46-38	118-09-11	2302	8.90 †	2.90 †
1268	PALMDALE RECLAMATION PLANT	SP	4196 F5	34-35-30	118-05-10	2565	8.70 †	2.65 †
1271	POMONA WASTE RECLAMATION	SP	640 E2	34-03-18	117-47-34	786	26.10 †	13.50 †
1274	WHITTIER - VALNA DRIVE	S	707 D1	33-57-39	118-01-10	255	29.68	11.14

### LEGEND:

- S Standard 8 inch diameter non-recording gage owned by the Department of Public Works
- 8.81 8.81 inch diameter non-recording gage owned by the Department of Public Works
- A Automatic recording gage owned by the Department of Public Works
- ST Storage type gage owned by the Department of Public Works
- SP Standard 8 inch diameter non-recording gage owned by outside interest
- AP Automatic recording gage owned by outside interest
- O.CO. Orange County Thomas Guide page
- V.CO. Ventura County Thomas Guide page
- S.B.CO San Bernardino County Thomas Guide page
- † Estimated Seasonal Total



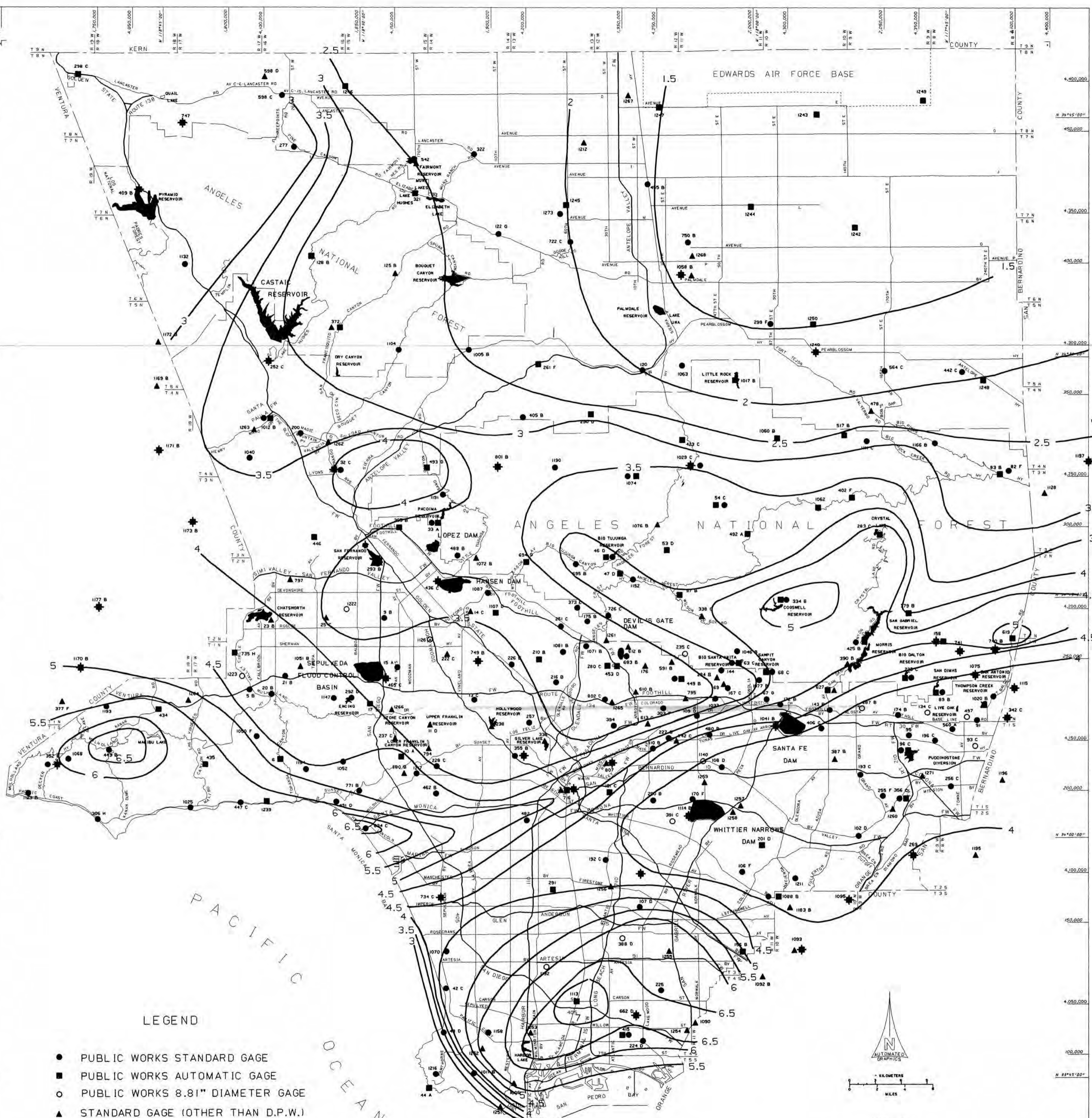

LEGEND

- PUBLIC WORKS STANDARD GAGE
- PUBLIC WORKS AUTOMATIC GAGE
- PUBLIC WORKS 8.81" DIAMETER GAGE
- ▲ STANDARD GAGE (OTHER THAN D.P.W.)
- ⊕ AUTOMATIC GAGE (OTHER THAN D.P.W.)

(LOCATIONS ARE APPROXIMATE)

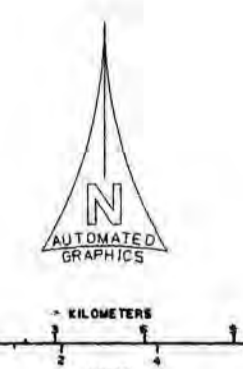

COUNTY OF LOS ANGELES

DEPARTMENT OF PUBLIC WORKS

ISOHYETAL MAP FOR JAN.4.5.1995 STORM

(RAINFALL IN INCHES)



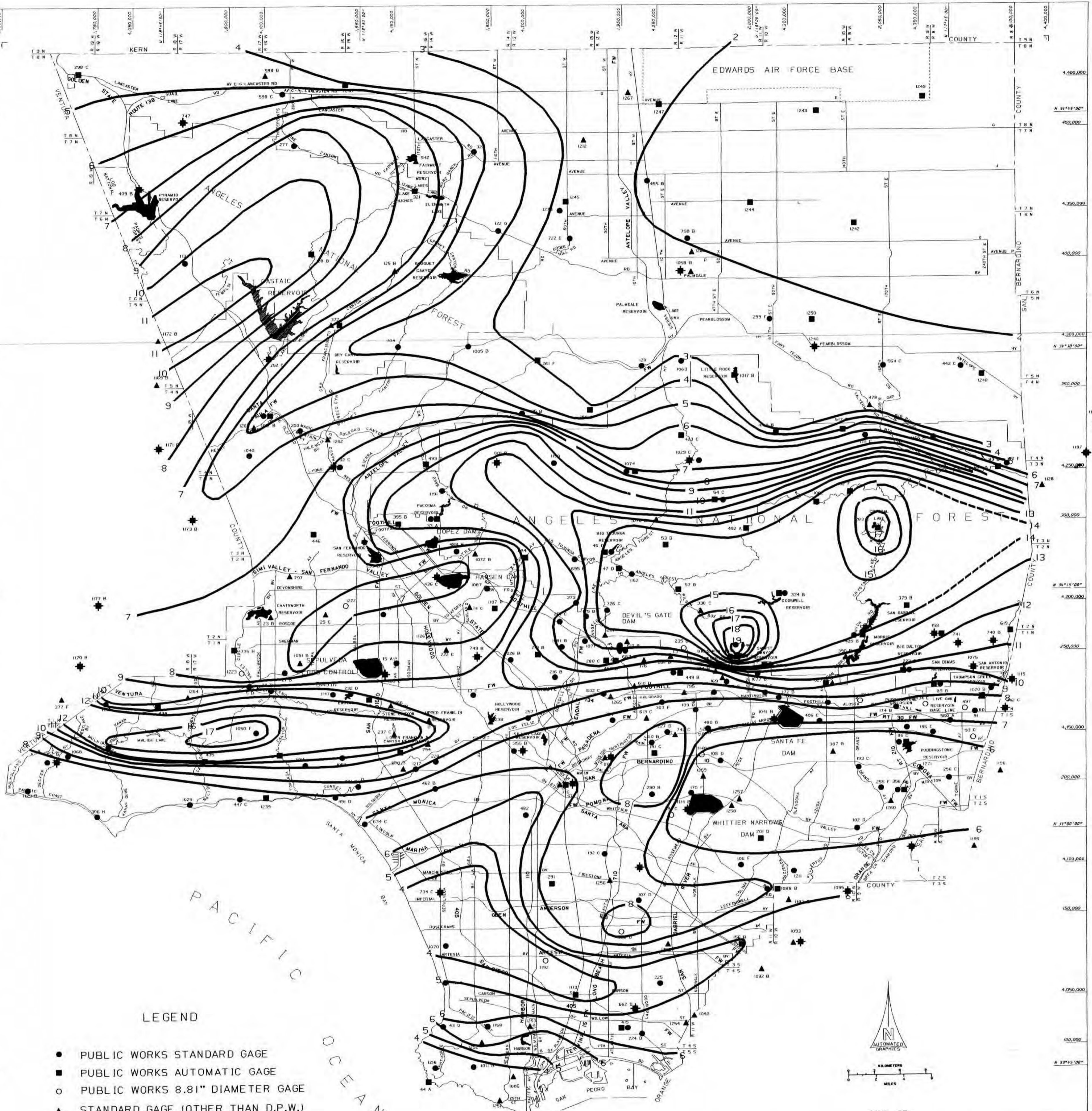

LEGEND

- PUBLIC WORKS STANDARD GAGE
- PUBLIC WORKS AUTOMATIC GAGE
- PUBLIC WORKS 8.8" DIAMETER GAGE
- ▲ STANDARD GAGE (OTHER THAN D.P.W.)
- ✱ AUTOMATIC GAGE (OTHER THAN D.P.W.)

(LOCATIONS ARE APPROXIMATE)

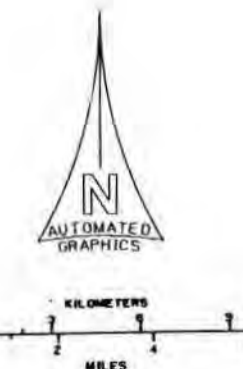

MAP OF COUNTY OF LOS ANGELES

DEPARTMENT OF PUBLIC WORKS

ISOHYETAL MAP

JAN 10, 1995 STORM

(RAINFALL IN INCHES)



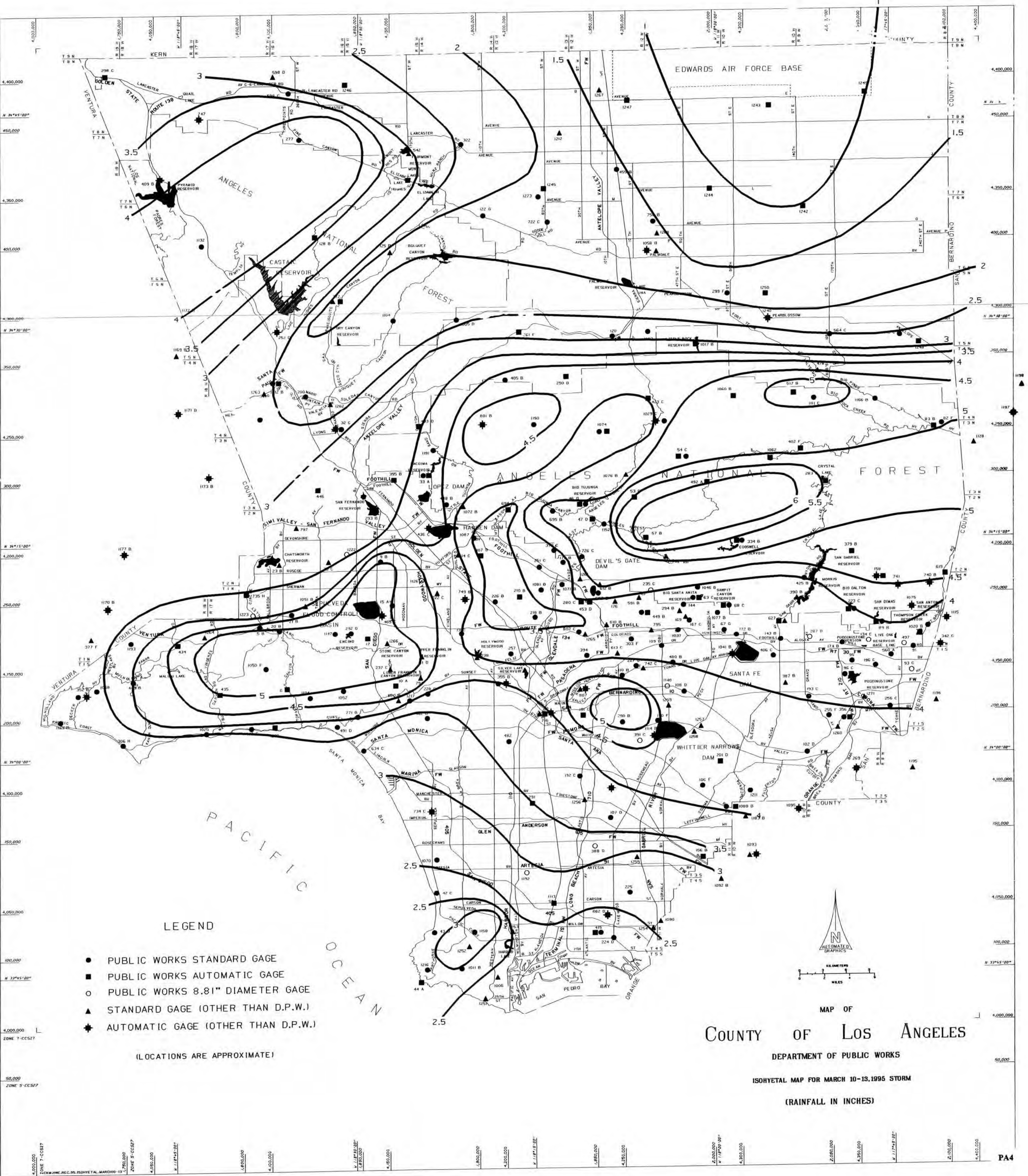

LEGEND

- PUBLIC WORKS STANDARD GAGE
- PUBLIC WORKS AUTOMATIC GAGE
- PUBLIC WORKS 8.81" DIAMETER GAGE
- ▲ STANDARD GAGE (OTHER THAN D.P.W.)
- ★ AUTOMATIC GAGE (OTHER THAN D.P.W.)

(LOCATIONS ARE APPROXIMATE)



MAP OF COUNTY OF LOS ANGELES

DEPARTMENT OF PUBLIC WORKS

ISOHYETAL MAP FOR MARCH 10-13, 1995 STORM

(RAINFALL IN INCHES)



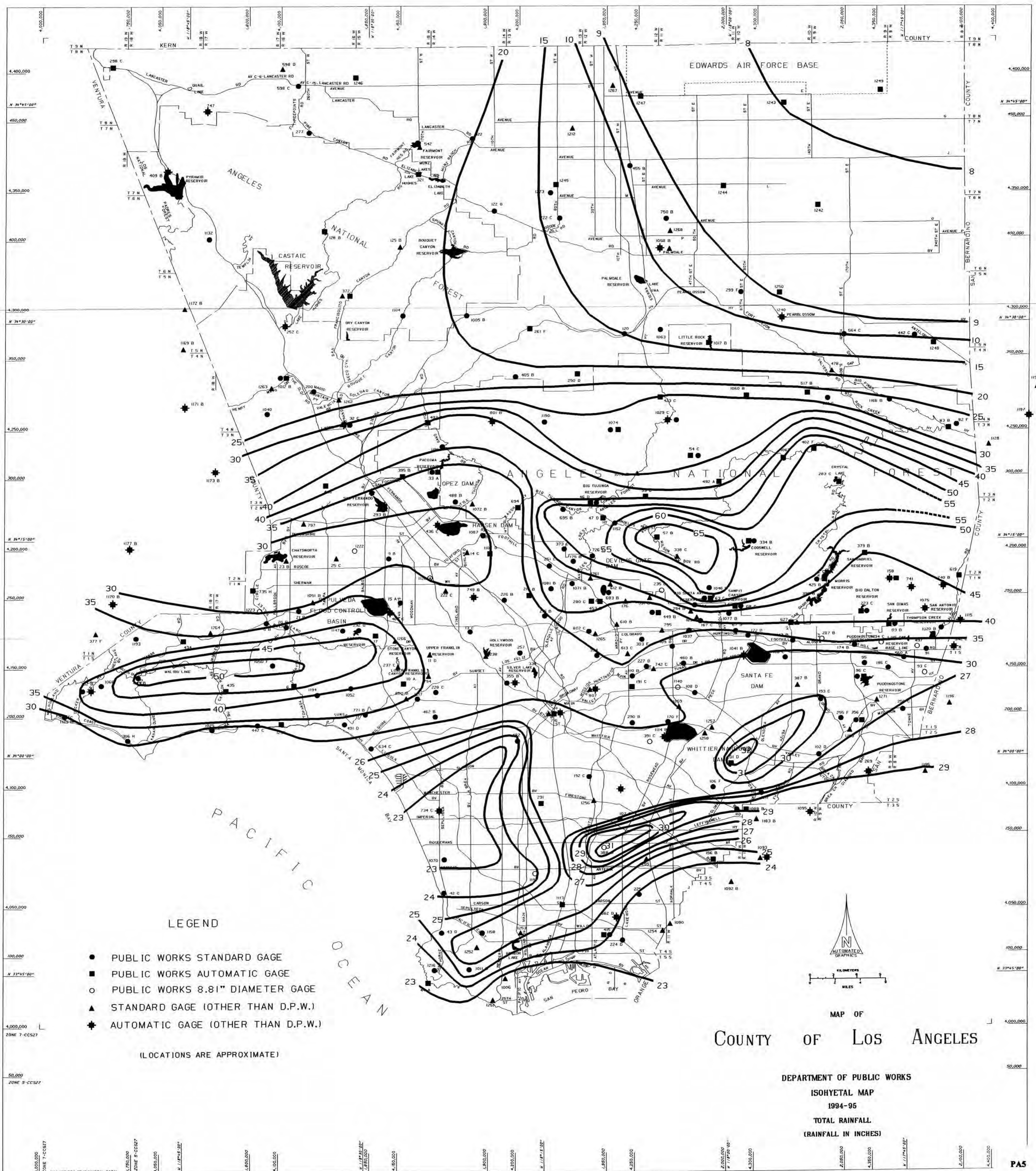

LEGEND

- PUBLIC WORKS STANDARD GAGE
- PUBLIC WORKS AUTOMATIC GAGE
- PUBLIC WORKS 8.81" DIAMETER GAGE
- ▲ STANDARD GAGE (OTHER THAN D.P.W.)
- ⊠ AUTOMATIC GAGE (OTHER THAN D.P.W.)

(LOCATIONS ARE APPROXIMATE)

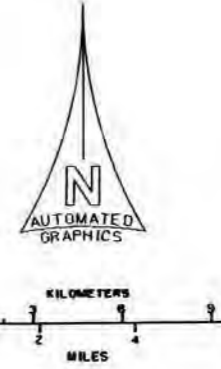

MAP OF  
COUNTY OF LOS ANGELES

DEPARTMENT OF PUBLIC WORKS  
ISORYETAL MAP  
1994-95  
TOTAL RAINFALL  
(RAINFALL IN INCHES)



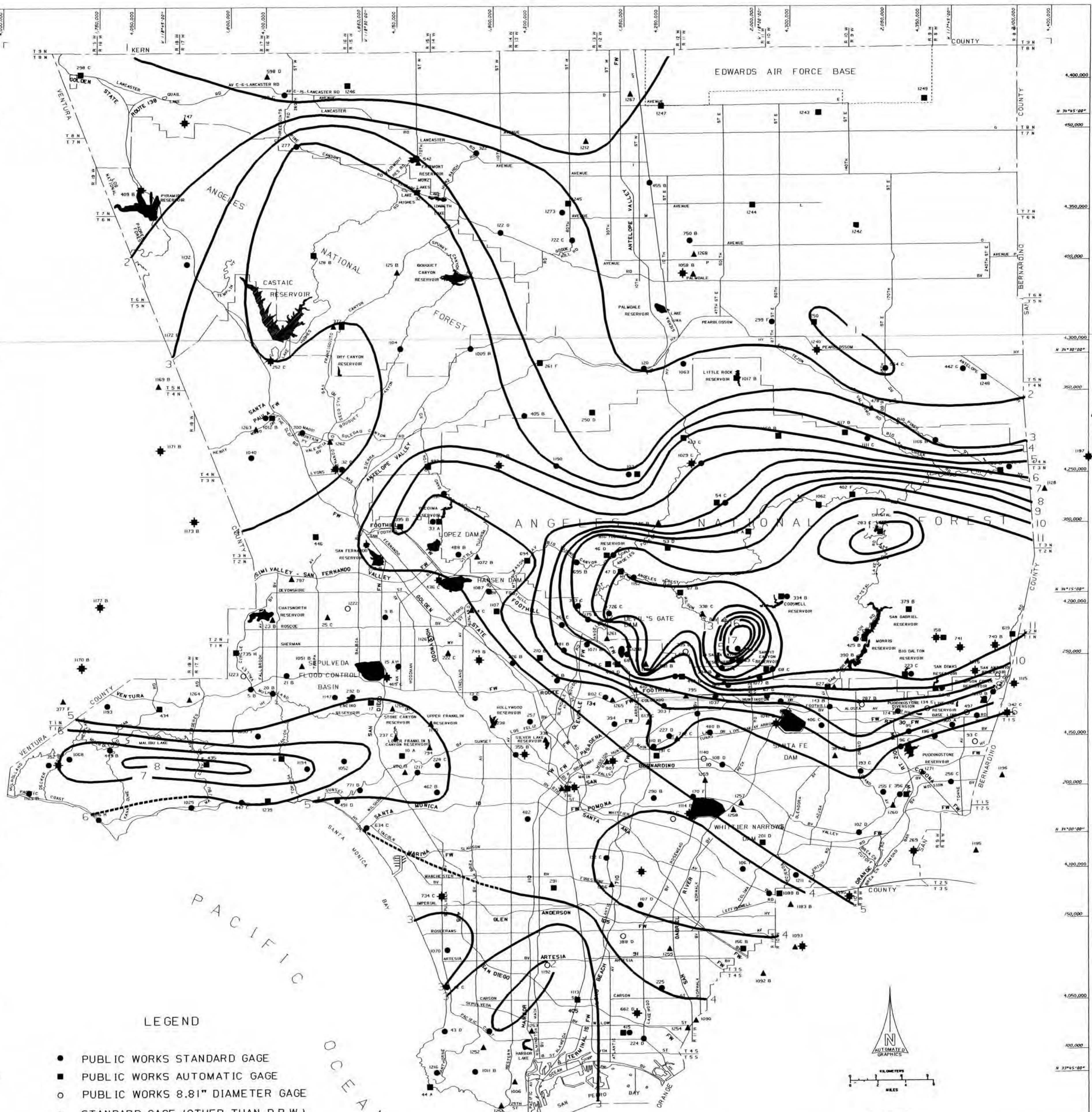

LEGEND

- PUBLIC WORKS STANDARD GAGE
- PUBLIC WORKS AUTOMATIC GAGE
- PUBLIC WORKS 8.81" DIAMETER GAGE
- ▲ STANDARD GAGE (OTHER THAN D.P.W.)
- ★ AUTOMATIC GAGE (OTHER THAN D.P.W.)

(LOCATIONS ARE APPROXIMATE)

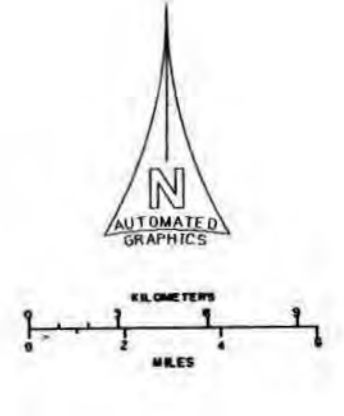

MAP OF  
COUNTY OF LOS ANGELES

DEPARTMENT OF PUBLIC WORKS

1996 ISORHYETAL MAP

FEBRUARY 19-22 STORM



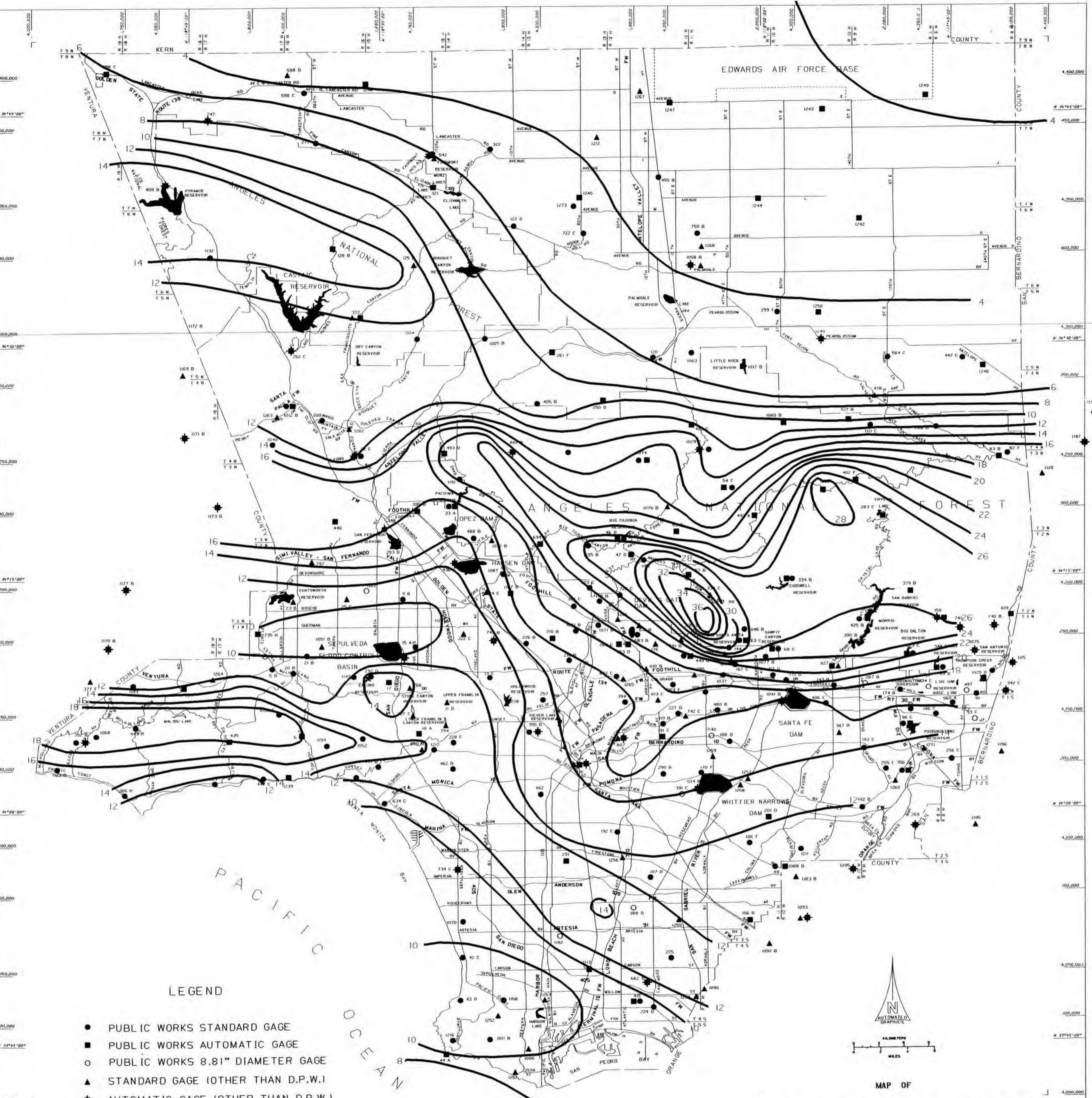

LEGEND

- PUBLIC WORKS STANDARD GAGE
- PUBLIC WORKS AUTOMATIC GAGE
- PUBLIC WORKS 8.81" DIAMETER GAGE
- ▲ STANDARD GAGE (OTHER THAN D.P.W.)
- ★ AUTOMATIC GAGE (OTHER THAN D.P.W.)

(LOCATIONS ARE APPROXIMATE)

MAP OF COUNTY OF LOS ANGELES

DEPARTMENT OF PUBLIC WORKS  
 1995-96 ISOHYETAL MAP  
 SEASONAL TOTAL  
 (RAINFALL IN INCHES)



# **EVAPORATION**

## EVAPORATION

Monthly and seasonal evaporation has been published in the Department's Annual or Biennial Reports on Hydrologic Data since the 1931-32 season. Data for 13 active evaporation stations were reported to the Department during the 1994-95 and 1995-96 water year. Daily records of active and inactive Department stations, as well as some stations of other agencies, are available in the Department's files.

### COOPERATION

The Department receives evaporation data from The Metropolitan Water District, Palmdale Water District, California Department of Water Resources, and Descanso Gardens.

### LENGTH OF RECORD

The Los Angeles County Flood Control District (now administered by the Department) installed its first land pan in March 1929 at Santa Anita Dam. The Department has 30 evaporation stations which have records of 15 seasons or more in the Department's files.

### ACTIVE EVAPORATION STATION LIST 1994-96

STA. NO.		STATION NAME	EQUIPMENT	ELEVATION OF PAN	THOMAS GUIDE	NORTH LATITUDE	WEST LONGITUDE
33	A	Pacoima Dam	24X36 S	1500 ft.	482 F1	34-19-48	118-23-59
46	D	Big Tujunga Dam	24X36 S	2315 ft.	xi	34-17-40	118-11-14
63	C	Santa Anita Dam	24X36 S	1400 ft.	710 B2	34-11-03	118-01-12
89	B	San Dimas Dam	24X36 S	1350 ft.	470 F2	34-09-10	117-46-17
96	C	Puddingstone Dam	24X36 S	1030 ft.	600 A4	34-05-31	117-48-24
223	B	Big Dalton Dam	24X36 S	1587 ft.	570 B4	34-10-06	117-48-36
252	C	Castaic Reservoir	48X10 S	1150 ft.	4369 H6	34-29-53	118-36-53
334	B	Cogswell Dam	24X36 S	2300 ft.	ix	34-14-37	117-57-35
390	B	Morris Dam	72X36 US	1210 ft.	ix	34-10-53	117-52-43
409	B	Pyramid Reservoir	48X10 S	2505 ft.	593 E1	34-40-34	118-46-47
425	B	San Gabriel Dam	24X36 S	1481 ft.	ix	34-12-19	117-51-38
1058	B	Palmdale	24X36 S	2595 ft.	4196 E6	34-35-17	118-05-31
1071	B	Descanso Gardens	24X36 S	1325 ft.	535 B4	34-12-07	118-12-46

### LEGEND

- 24X36 S** = Screened land pan, 24 inches in diameter by 36 inches deep.
- 48X10 S** = Screened land pan, 48 inches in diameter by 10 inches deep.
- 72X36 US** = Unscreened land pan, 72 inches in diameter by 36 inches deep.

## MONTHLY EVAPORATION SUMMARY

### WATER YEAR 1994-95

Station Number	Station Name	Oct	Nov	Dec	Jan	Feb	Mar	Apr	May	Jun	Jul	Aug	Sep	Total
33-A	Pacoima Dam	8.12	6.47	5.34	2.38	5.41	4.32	6.62	4.55	6.67	11.56	12.33	10.99	84.76
46-D	Big Tujunga Dam	5.84	4.55	3.02	2.17	3.49	4.43	5.20	5.11	7.76	11.85	13.62	10.49	77.53
63-C	Santa Anita Dam	4.85	3.46	2.72	1.08	2.33	2.85	3.36	2.16	3.62	6.51	7.46	6.76	47.16
89-B	San Dimas Dam	3.43	2.42	1.49	1.67	1.67	2.23	3.65	3.24	4.91	7.97	9.06	6.83	48.57
96-C	Puddingstone Dam	10.13	3.54	2.35	2.18	2.30	3.11	5.32	4.54	6.98	9.76	11.22	9.86	71.29
223-B	Big Dalton Dam	3.56	2.68	1.56	0.89	1.29	1.82	3.54	2.93	4.59	8.84	8.84	6.60	47.14
252-C	Castaic Dam	6.14	3.41	2.87	4.05	2.15	1.37	4.20	4.86	6.72	8.11	8.24	8.03	60.15
334-B	Cogswell Dam	3.94	2.04	1.22	0.61	1.24	1.89	3.60	3.38	5.97	8.35	8.79	7.01	48.04
390-B	Morris Dam	6.83	4.39	3.38	3.00	4.08	4.85	9.72	5.05	8.15	11.93	13.21	10.90	85.49
409-B	Pyramid Reservoir	5.49	3.47	2.88	4.05	2.28	4.22	4.53	5.17	7.74	9.26	9.14	8.15	66.38
425-B	San Gabriel Dam	6.49	4.31	3.59	1.32	3.05	3.55	4.99	4.47	6.38	9.79	10.72	9.16	67.82
1014-F	Rio Hondo SG	5.57	3.93	Discontinued										Inc.
1058-B	Palmdale	6.22	3.94	2.22	1.77	2.72	4.23	7.21	9.10	11.82	15.78	16.30	10.91	92.22
1071-B	Descanso Gardens	3.67	2.24	1.82	1.38	1.25	2.00	3.17	3.02	4.15	6.35	7.52	6.18	42.75

### WATER YEAR 1995-96

Station Number	Station Name	Oct	Nov	Dec	Jan	Feb	Mar	Apr	May	Jun	Jul	Aug	Sep	Total
33-A	Pacoima Dam	8.77	7.42	5.31	5.63	3.99	5.44	9.36	7.65	8.35	10.15	11.50	8.31	91.88
46-D	Big Tujunga Dam	9.04	5.68	3.90	4.47	2.36	4.69	6.53	9.15	10.49	13.04	13.42	9.28	92.05
63-C	Santa Anita Dam	4.98	4.19	3.52	2.67	1.65	2.79	4.09	4.68	5.60	6.42	6.84	5.25	52.68
89-B	San Dimas Dam	3.81	2.15	1.73	1.71	1.62	2.74	4.65	5.88	6.82	7.96	8.31	5.80	53.18
96-C	Puddingstone Dam	6.68	4.10	2.59	2.98	2.28	4.43	6.37	7.66	9.38	11.11	11.05	8.44	77.07
223-B	Big Dalton Dam	4.13	2.49	1.78	1.92	1.14	2.19	4.56	5.24	6.66	8.07	8.14	5.48	51.80
252-C	Castaic Dam	6.59	3.85	2.70	2.50	3.90	2.81	7.92	6.56	7.58	9.51	10.48	7.63	72.03
334-B	Cogswell Dam	2.67	4.78	1.61	1.49	1.24	2.32	4.20	5.06	7.34	8.83	8.77	6.13	54.44
390-B	Morris Dam	7.70	3.70 <sup>†</sup>	3.41	3.60	3.04	6.55	7.52	8.47	10.14	12.11	12.30	8.96	87.50
409-B	Pyramid Reservoir	6.65	5.38	2.57	2.70	3.90	3.81	7.34	7.47	9.78	10.21	11.69	6.42	77.92
425-B	San Gabriel Dam	7.59	4.98	3.86	3.54	2.63	4.41	6.63	7.24	8.47	9.79	10.02	7.79 <sup>†</sup>	69.16
1058-B	Palmdale	6.56	3.71	2.13	2.91	2.03	4.36	8.18	10.94	12.46	13.93	13.33	9.85	90.39
1071-B	Descanso Gardens	3.71	2.11	1.37	1.87	1.40	2.39	4.28	5.41	6.31	7.71	7.48	5.64	49.68

Legend:

- † - Estimated
- Inc. - Incomplete Record



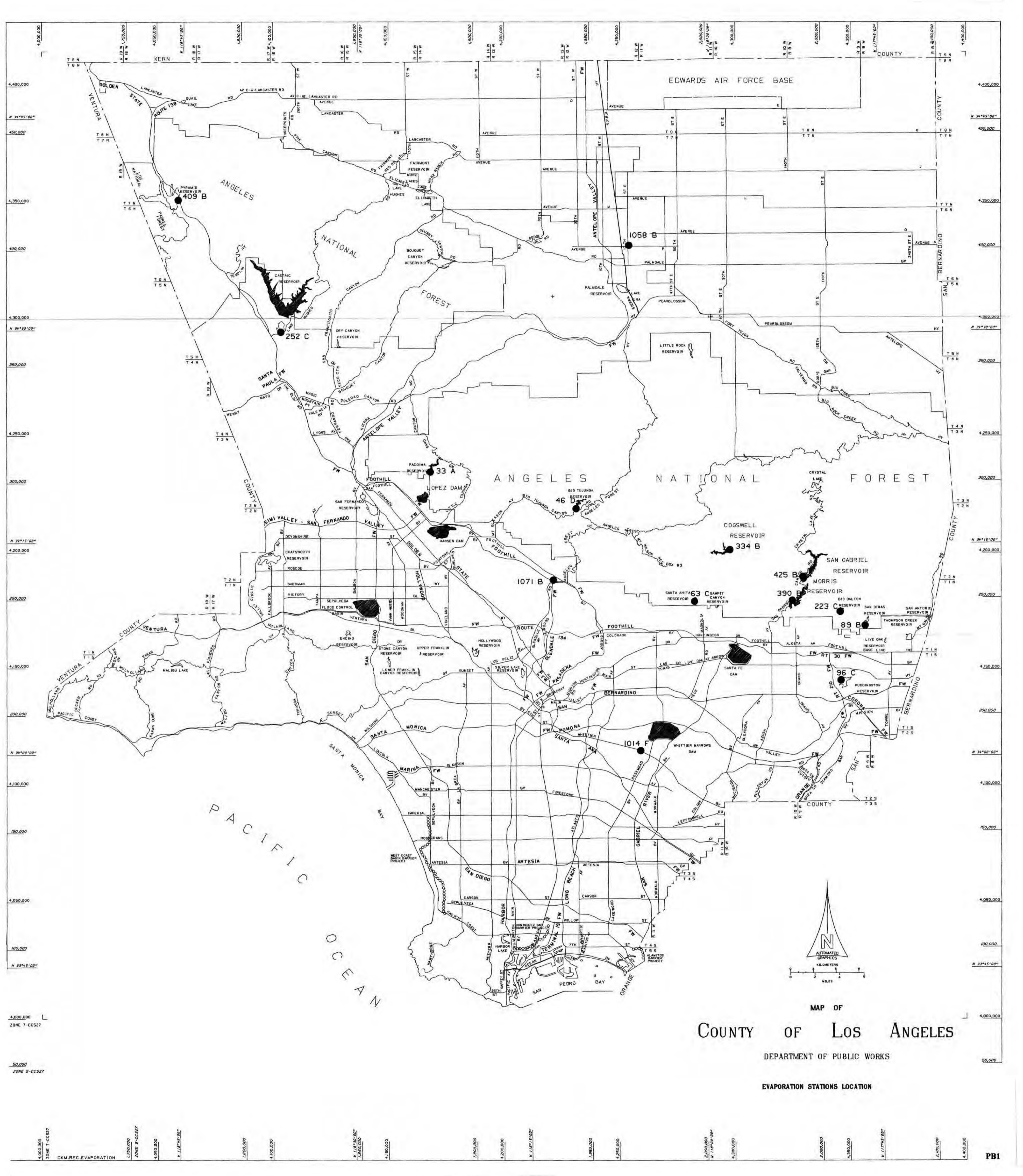

MAP OF  
**COUNTY OF LOS ANGELES**  
 DEPARTMENT OF PUBLIC WORKS  
 EVAPORATION STATIONS LOCATION

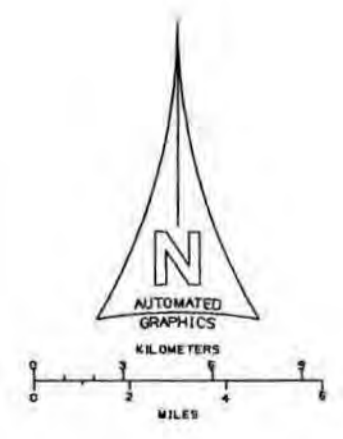

50,000  
 ZONE 5-CC527

4,000,000  
 ZONE 7-CC527  
 CKM.REC.EVAPORATION

**RUNOFF**

## **RUNOFF**

The Department operated 62 water-stage recording stations and 3 witness gages during the 1994-95 and 1995-96 Water Years. Data from 40 of those stations are summarized and published in this volume.

### **RECORDS OF STREAMFLOW**

Published records give the following information:

1. Station description presents location, drainage area, type of channel, control, regulations, diversions, and available records.
2. Discharge tabulation summarizes the maximum, minimum, and mean of the daily flow rates in second-feet for each month and the total monthly volumes in acre-feet.

### **ALERT SYSTEM (AUTOMATIC LOCAL EVALUATION IN REAL TIME)**

The Department of Public Works has installed a state-of-the-art ALERT computer system to monitor meteorological conditions at 30 river stage locations in the County.

During the report period, the Department has continued to install and expand its ALERT System. The Department's ALERT System also receives rainfall, streamflow, and reservoir data from the Corps of Engineers' Los Angeles Telemetry System.

### **COOPERATION**

The Department receives or has access to streamflow data from other agencies. Data from 5 of the Department's stations are published in the United States Geological Survey's annual water supply papers.

Agencies with which the Department exchanges data are:

United States Geological Survey, Water Resource Division  
United States Army Corps of Engineers  
State Department of Water Resources  
The Metropolitan Water District of Southern California  
San Gabriel River Water Committee

## LEGEND

Stations are designated by letters and numbers which indicate ownership, operation agency, and type of station. The letters used have the following connotations:

**Prefix F** - Indicates a station owned and operated by the Los Angeles County Department of Public Works.

**Prefix E** - Indicates a station owned by the Corps of Engineers, Department of the Army, but operated and maintained by the United States Geological Survey.

**Prefix U** - Indicates a station originally constructed and operated by the United States Geological Survey, Water Resources Division, now operated by the Department.

**Prefix P** - Indicates a station owned and operated by the Department, formerly operated by the Pasadena Water Department.

**Prefix L** - Indicates a station owned and operated by the Department, formerly owned by Little Rock Water District.

**Suffix R** - Indicates a recorder station.

**Suffix B** - Indicates that the station has been moved. B represents second location, C a third location, etc.



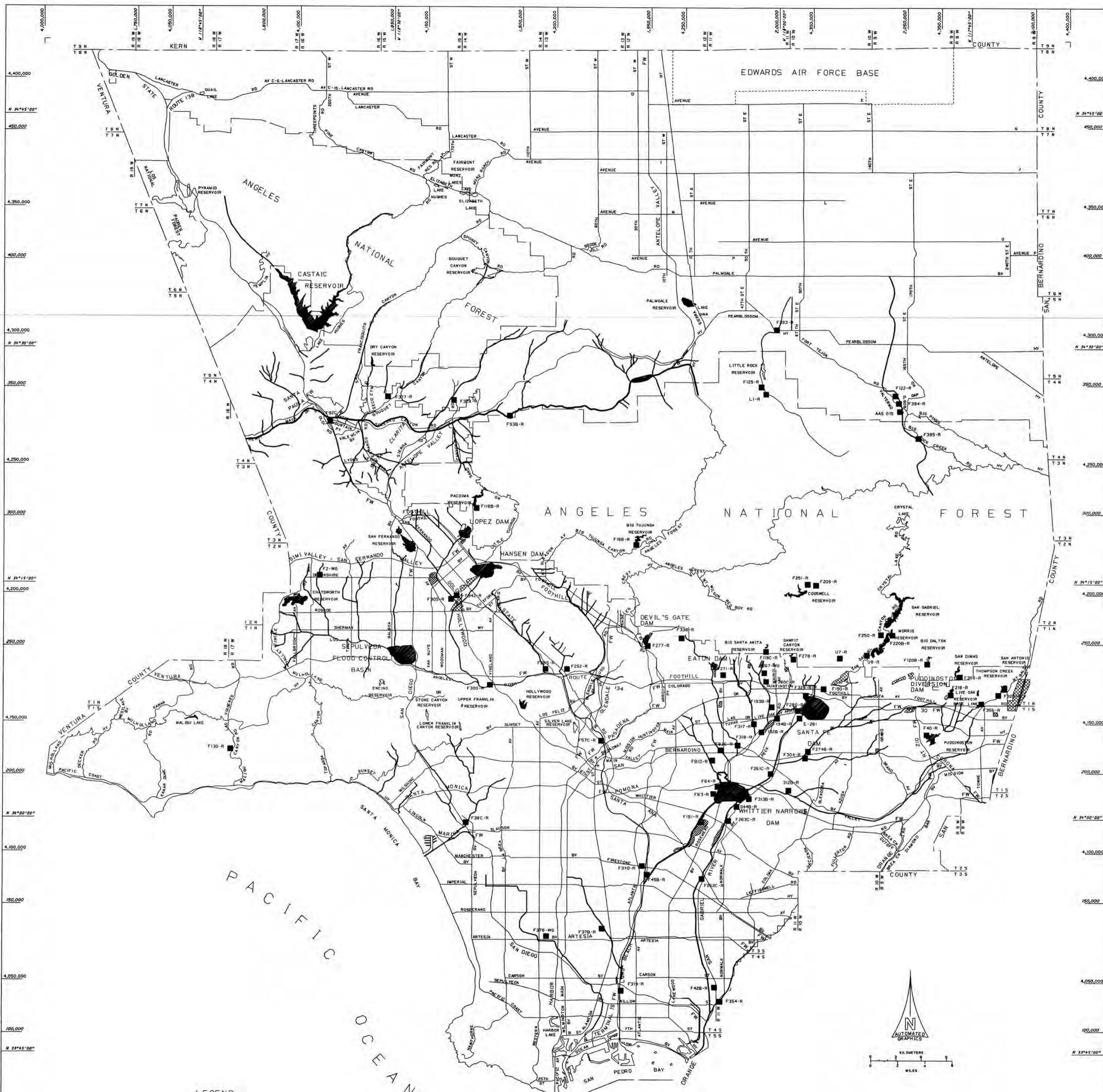

LEGEND

■ ACTIVE STREAMFLOW GAGES  
(LOCATIONS ARE APPROXIMATE)

SPREADING GROUNDS

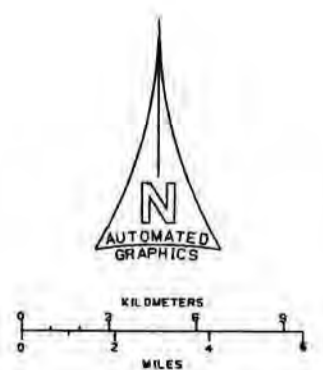

MAP OF  
COUNTY OF LOS ANGELES

DEPARTMENT OF PUBLIC WORKS  
STREAMFLOW GAGING STATION LOCATIONS

4,000,000  
ZONE 7-CC527

50,000  
ZONE 5-CC527

4,000,000  
ZONE 7-CC527

1,750,000  
ZONE 5-CC527

4,050,000  
N 33°45'00"

1,800,000  
W 117°45'00"

4,100,000

4,150,000

4,200,000

4,250,000

4,300,000

4,350,000

4,400,000

4,450,000

4,500,000

4,550,000

4,600,000

4,650,000

4,700,000

4,750,000

4,800,000

4,850,000

4,900,000

4,950,000

5,000,000

5,050,000

5,100,000

5,150,000

5,200,000

5,250,000

5,300,000

5,350,000

5,400,000

5,450,000

5,500,000

5,550,000

5,600,000

5,650,000

5,700,000

5,750,000

5,800,000

5,850,000

5,900,000

5,950,000

6,000,000

6,050,000

6,100,000

6,150,000

6,200,000

6,250,000

6,300,000

6,350,000

6,400,000

6,450,000

6,500,000

6,550,000

6,600,000

6,650,000

6,700,000

6,750,000

6,800,000

6,850,000

6,900,000

6,950,000

7,000,000

7,050,000

7,100,000

7,150,000

7,200,000

7,250,000

7,300,000

7,350,000

7,400,000

7,450,000

7,500,000

7,550,000

7,600,000

7,650,000

7,700,000

7,750,000

7,800,000

7,850,000

7,900,000

7,950,000

8,000,000

8,050,000

8,100,000

8,150,000

8,200,000

8,250,000

8,300,000

8,350,000

8,400,000

8,450,000

8,500,000

8,550,000

8,600,000

8,650,000

8,700,000

8,750,000

8,800,000

8,850,000

8,900,000

8,950,000

9,000,000

9,050,000

9,100,000

9,150,000

9,200,000

9,250,000

9,300,000

9,350,000

9,400,000

9,450,000

9,500,000

9,550,000

9,600,000

9,650,000

9,700,000

9,750,000

9,800,000

9,850,000

9,900,000

9,950,000

10,000,000



## INDEX OF STREAM GAGING STATIONS

STATION	NAME	THOMAS GUIDE PG.	ALERT NO.	REGU- LATED	DRAINAGE AREA *
L1-R	LITTLE ROCK CREEK ABOVE LITTLE ROCK DAM	J		NO	49.20
F2WG	BROWNS CREEK AT VARIEL AVENUE	6 / D-2		NO	13.50
U7-R	FISH CREEK ABOVE MOUTH OF CANYON	86 / B-2		NO	6.36
U8-R	SAN GABRIEL RIVER BELOW MORRIS DAM	86 / F-1	415	YES	212.40
AAS(015)	VALYERMO S.G., BIG ROCK CK. D/S VALYERMO RD.	192/H-5			
F32B-R	THOMPSON CREEK BELOW THOMPSON CREEK DAM	96 / C-5	433	YES	3.70
F34D-R	LOS ANGELES RIVER BELOW FIRESTONE BLVD.	59 / E-3	315	YES	596.00
F37B-R	COMPTON CREEK NEAR GREENLEAF DRIVE	64 / F-4		NO	22.60
F38C-R	BALLONA CREEK ABOVE SAWTELLE BLVD.	50 / B-3	369	YES	88.60
F40-R	PUDDINGSTONE CREEK BELOW PUDDINGSTONE DAM	89 / F-4	427	YES	33.20
F42B-R	SAN GABRIEL RIVER ABOVE SPRING STREET	76 / F-1	435	YES	231.00
F45B-R	RIO HONDO ABOVE STUART AND GRAY ROAD	59 / E-3	307	YES	140.00
F57C-R	LOS ANGELES RIVER ABOVE ARROYO SECO	35 / F-5		YES	511.00
F64-R	RIO HONDO ABOVE MISSION BRIDGE	47 / B-5		YES	115.00
F81D-R	ALHAMBRA WASH NEAR KLINGERMAN STREET	46 / F-2	347	NO	15.20
F82C-R	RUBIO WASH AT GLENDON WAY	38 / A-6	353	YES	10.90
F83	MISSION CREEK AT SAN GABRIEL BLVD.			YES	4.2
F92C-R	SANTA CLARA RIVER AT OLD ROAD BRIDGE	123 / G-7		YES	410.40
F93	SANTA CLARA RIVER AT LANG RAILROAD BRIDGE	125 / J-7		NO	157.30
F118B-R	PACOIMA CREEK FLUME BELOW PACOIMA DAM	3 / C-1	330	YES	28.20
F119C-R	SANTA ANITA CREEK BELOW SANTA ANITA DAM	20A / F-2	345	YES	10.80
F120B-R	BIG DALTON CREEK BELOW BIG DALTON DAM	87 / F-2	418	YES	4.80
F122-R	PALLETT CREEK AT VALYERMO HIGHWAY	199 / G-4		NO	15.80
F125-R	SANTIAGO CREEK ABOVE LITTLE ROCK CREEK	J		NO	11.20
F130-R	MALIBU CREEK BELOW COLD CREEK	107 / F-6		YES	104.96
F168-R	BIG TUJUNGA CREEK BELOW BIG TUJUNGA DAM	M / C-2	333	YES	82.30
F181-R	MONTEBELLO STORM DRAIN OUTLET TO RIO HONDO	54 / E-3		NO	9.60
F190-R	SAN GABRIEL RIVER AT FOOTHILL BLVD.	86 / A-5		YES	230.00
F192B-R	RIO HONDO BELOW LOWER AZUSA ROAD	38 / E-4		YES	40.90
F193B-R	SANTA ANITA WASH AT LONGDEN AVENUE	38 / F-1		YES	18.80
F194B-R	SAWPIT WASH BELOW LIVE OAK AVENUE	39 / A-2		YES	16.10
F209-R	SAN GABRIEL RIVER - W. FORK BELOW COGSWELL DAM	N / D-4	410	YES	41.00
F218-R	SAN DIMAS WASH BELOW PUDD. DIVERSION DAM	95A / C-5	424	YES	19.90
F220B-R	SAN GABRIEL - AZUSA CONDUIT 10FT WEIR BELOW DAM	P / A-5		YES	0.00
F250-R	SAN GABRIEL - AZUSA CONDUIT 25FT WEIR BELOW DAM	P / A-5		YES	202.70
F251-R	SAN GABRIEL W. FORK AT TOE OF COGSWELL DAM	N / D-4		YES	39.20
F252-R	VERDUGO WASH AT ESTELLE AVENUE	25 / B-3		YES	26.80
F260C-R	SANTA ANITA WASH BELOW FOOTHILL BLVD.	28 / E-3		YES	17.20
F261C-R	SAN GABRIEL RIVER BELOW VALLEY BLVD.	48 / A-2	351	YES	118.00
F262C-R	SAN GABRIEL RIVER ABOVE FLORENCE AVE.	60 / E-4		YES	215.80
F263C-R	SAN GABRIEL RIVER BELOW S.G. RIVER PKWY	55 / C-1		YES	206.30
F267WG	SIERRA MADRE WASH AT HIGHLAND OAKS AVENUE	28 / E-3		YES	3.80
F271-R	EATON WASH BELOW EATON WASH DAM	27 / F-1	342	YES	12.40
F274B-R	DALTON WASH AT MERCED AVENUE	48 / F-1		YES	35.95
F277-R	ARROYO SECO BELOW DEVIL'S GATE DAM	19 / D-5	336	YES	32.50
F278-R	SAWPIT CREEK BELOW SAWPIT DAM	29 / C-1	339	YES	3.30
F280-R	SANTA FE DIVERSION CHANNEL BELOW SANTA FE DAM	39 / D-2		YES	CONTROLLED
E285-R	BURBANK WESTERN STORM DRAIN AT RIVERSIDE DR.	24 / E-2		YES	25.00
F300-R	LOS ANGELES RIVER AT TUJUNGA AVE.	23 / D-4		YES	401.00

## INDEX OF STREAM GAGING STATIONS

STATION	NAME	THOMAS GUIDE PG.	ALERT NO.	REGU- LATED	DRAINAGE AREA *
F303-R	SAN DIMAS CREEK BELOW SAN DIMAS DAM	95A / C-3	421	YES	16.20
F304-R	WALNUT CREEK ABOVE PUENTE AVENUE	48 / D-1		YES	57.60
F305-R	PACOIMA DIVERSION AT BRANFORD STREET	9 / A-5		YES	48.80
F312B-R	SAN JOSE CHANNEL BELOW SEVENTH AVE.	47 / F-5	324	YES	83.40
F313B-R	RIO HONDO BYPASS CHANNEL ABOVE WHITTIER NAR.	47 / B-5		YES	CONTROLLED
F317-R	ARCADIA WASH BELOW GRAND AVENUE	38 / E-3	355	YES	8.50
F318-R	EATON WASH AT LOFTUS DRIVE	34 / C-6		YES	22.80
F319-R	LOS ANGELES RIVER BELOW WARDLOW RIVER RD.	70 / B-5	313	YES	815.00
F328-R	MINT CANYON CREEK AT FITCH AVENUE	125 / C-5		NO	26.90
F329-R	BRADBURY CHANNEL BELOW CENTRAL AVENUE	29 / F-5		YES	3.30
F338-R	RUBIO DIV. CHANNEL BEL. GOOSEBERRY CYN INLET	20 / C-4		YES	2.10
F342-R	BRANFORD STREET CHANNEL BELOW SHARP AVE.	9 / B-5		YES	5.01
F354-R	COYOTE CREEK BELOW SPRING STREET	76 / F-1	437	YES	185.00
F356-R	LIVE OAK CREEK BELOW LIVE OAK DAM	95A / F-6	430	YES	2.28
F377-R	BOUQUET CANYON CREEK AT URBANDALE AVENUE	124 / F-5		YES	51.90
F378WG	DOMINGUEZ CHANNEL BELOW WESTERN AVENUE	63 / F-5		NO	37.10
F393-R	LITTLE ROCK AT HIGHWAY 138	184 / D-6		YES	70.00
F394-R	BIG ROCK CREEK UPSTREAM FROM PALLETT CREEK	192 / J-4		NO	34.30
F395-R	MESCAL CREEK AT MOUTH	J		NO	5.71
G44B-R	SAN GABRIEL RIVER ABOVE WHITTIER NAR. DAM	47 / C-6		NO	

\* NOTE: All drainage areas in square miles.

# LITTLE ROCK CREEK

## above Little Rock Dam

### STATION NO. L1-R

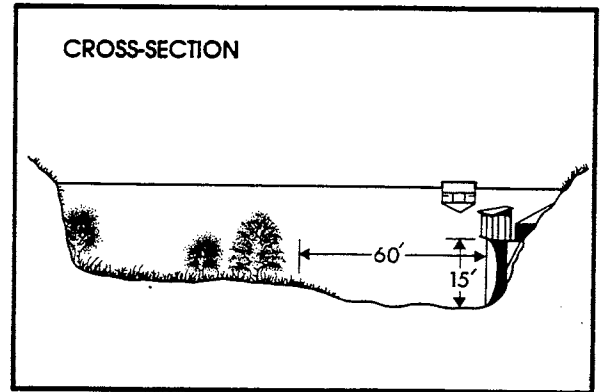
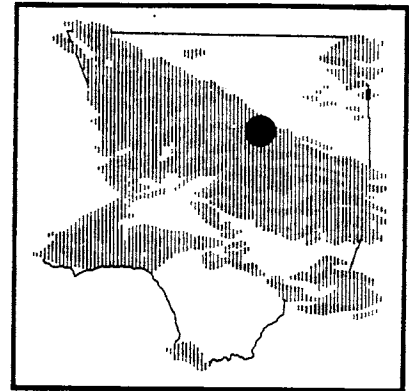
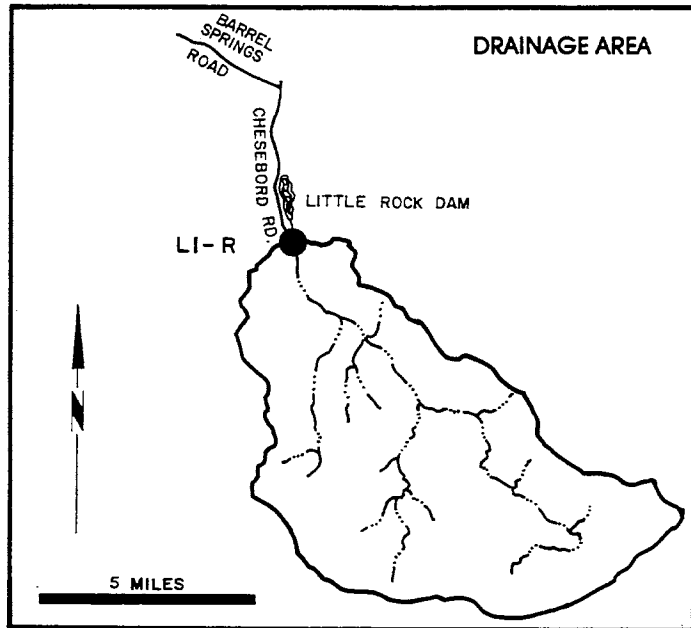

RECORDER- continuous water stage.  
 METHOD OF MEASUREMENTS- wading or from cable car.  
 DRAINAGE AREA- 49.2 square miles.  
 LOCATION- 2.0 miles above Little Rock Dam, 5.0 miles south of Little Rock.  
 REGULATION- none.  
 CHANNEL- sand, gravel, and boulders, natural in section.  
 CONTROL- channel forms control.  
 LENGTH OF RECORD- October 1, 1930 to date.

### WATER YEAR 1994-1995 (DISCHARGE IN CFS)

MONTH	OCT	NOV	DEC	JAN	FEB	MAR	APR	MAY	JUN	JUL	AUG	SEP
MEAN	0.0	0.6	2.0	137.0	94.5	187.0	59.3	40.9	12.4	4.6	1.3	0.1
MAX.	0.0	2.4	3.3	791.0	170.0	795.0	87.1	69.1	21.1	7.1	3.3	0.3
MIN	0.0	0.0	1.5	2.3	14.3	38.0	41.9	22.2	6.8	3.3	0.0	0.0
TOTAL AF	0.0	35.0	124.0	8,412.0	5,248.0	11,500.0	3,529.0	2,516.0	739.0	284.0	81.0	4.0

### WATER YEAR 1995-1996 (DISCHARGE IN CFS)

MONTH	OCT	NOV	DEC	JAN	FEB	MAR	APR	MAY	JUN	JUL	AUG	SEP
MEAN	0.0	7.7	3.9	2.4	54.6	28.6	8.7	2.9	0.5	0.0	0.0	0.0
MAX.	0.1	32.0	5.6	4.2	638.0	77.4	14.2	5.5	1.4	0.0	0.0	0.0
MIN	0.0	0.0	2.4	1.8	3.4	13.4	5.5	0.7	0.0	0.0	0.0	0.0
TOTAL AF	1.0	460.0	243.0	150.0	3,138.0	1,756.0	520.0	178.0	28.0	0.0	0.0	0.0

Note : All figures are in terms of daily amounts, i.e., Mean Daily, Maximum Daily & Minimum Daily.



# FISH CREEK

## above Mouth of Canyon

### STATION NO. U7-R

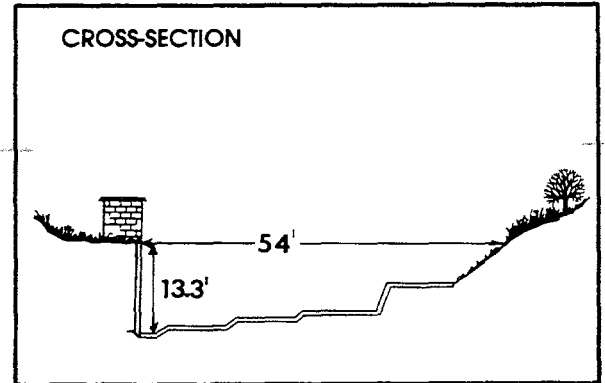
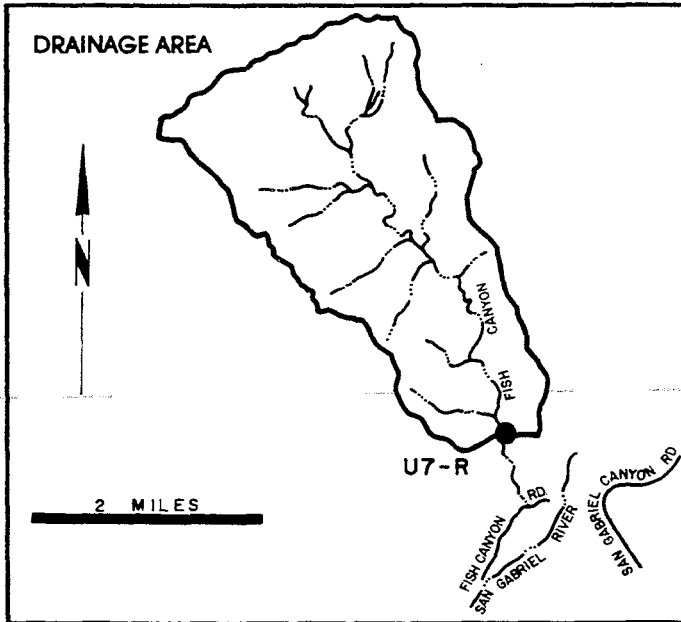
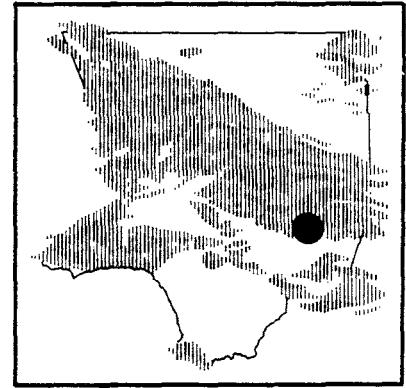

RECORDER- continuous water stage.  
 METHOD OF MEASUREMENTS- wading.  
 DRAINAGE AREA- 6.36 square miles.  
 LOCATION - 0.8 miles upstream of mouth of canyon and 3.0 miles northeast of Duarte.  
 REGULATION- none.  
 CHANNEL- natural, rock and gravel.  
 CONTROL- concrete control.  
 LENGTH OF RECORD- July to September 1916. July 1917 to date.  
 REMARKS- operated and maintained by USGS until October 1, 1971.

#### WATER YEAR 1994-1995 (DISCHARGE IN CFS)

MONTH	OCT	NOV	DEC	JAN	FEB	MAR	APR	MAY	JUN	JUL	AUG	SEP
MEAN	0.7	0.9	1.6	28.6	16.5	50.4	14.0	6.1	3.7	1.7	1.2	0.7
MAX	1.5	3.9	8.0	248.0	140.0	184.0	22.7	8.7	7.4	1.9	1.4	0.8
MIN	0.2	0.2	0.9	1.7	1.6	8.9	9.0	4.1	2.0	1.4	1.0	0.6
TOTAL AF	46.0	56.0	100.0	1,760.0	916.0	3,097.0	834.0	373.0	219.0	103.0	74.0	41.0

#### WATER YEAR 1995-1996 (DISCHARGE IN CFS)

MONTH	OCT	NOV	DEC	JAN	FEB	MAR	APR	MAY	JUN	JUL	AUG	SEP
MEAN	0.7	0.7	0.8	1.3	26.0	22.9	5.8	3.0	1.4	0.6	0.3	0.2
MAX	0.8	0.8	0.9	1.8	295.0	123.0	7.6	4.0	3.1	0.7	0.4	0.2
MIN	0.6	0.7	0.7	0.9	0.2	6.6	4.8	0.6	0.7	0.5	0.2	0.1
TOTAL AF	41.0	42.0	49.0	79.0	1,496.0	1,405.0	345.0	182.0	85.0	37.0	20.0	9.0

Note : All figures are in terms of daily amounts, i.e., Mean Daily, Maximum Daily & Minimum Daily.

# SAN GABRIEL RIVER

## below Morris Dam

### STATION NO.U8-R

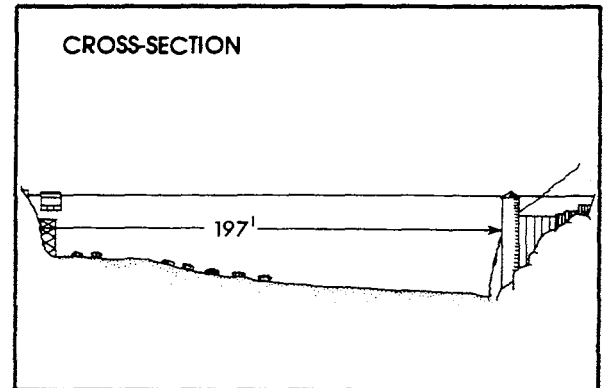
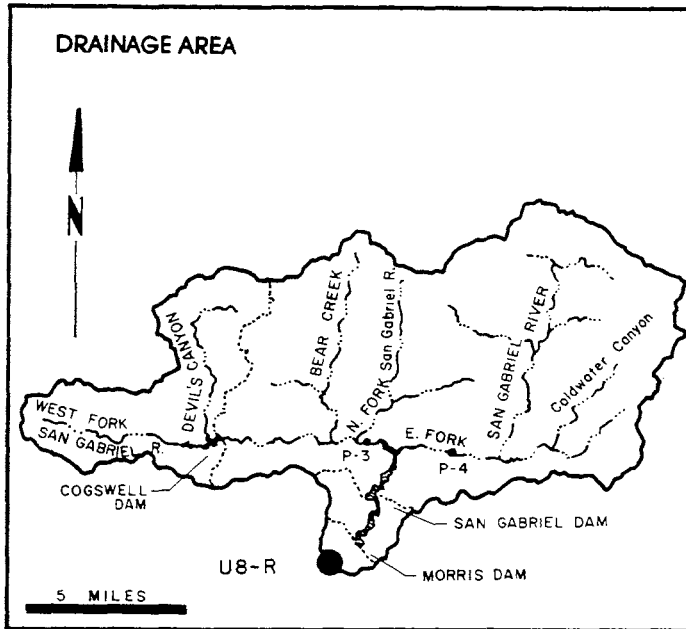
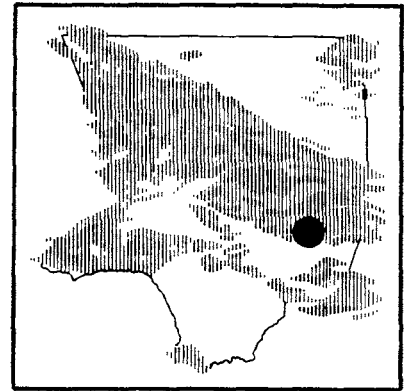

RECORDER- continuous water stage.

METHOD OF MEASUREMENTS- wading or from cable car.

DRAINAGE AREA- 212.4 square miles.

LOCATION- 1.1 miles downstream of Morris Dam, 2.7 miles northeast of Azusa.

REGULATION- all flows regulated by Cogswell, San Gabriel, and Morris Dams.

CHANNEL- gravel and boulders, natural section.

CONTROL- concrete control.

LENGTH OF RECORD- May 1894 to date.

REMARKS- flows up to 90 cfs are at times diverted past the station through the Azusa Conduit; flows at station may include imported water from the MWD outlet below Morris Dam.

### WATER YEAR 1994-1995 (DISCHARGE IN CFS)

MONTH	OCT	NOV	DEC	JAN	FEB	MAR	APR	MAY	JUN	JUL	AUG	SEP
MEAN	7.0	73.6	219.0	314.0	658.0	OUT	499.0	341.0	189.0	301.0	53.5	6.5
MAX	123.0	518.0	701.0	1,720.0	1,470.0	OF	677.0	657.0	411.0	627.0	595.0	8.7
MIN	0.0	0.3	0.3	0.3	458.0	SERVICE	408.0	2.8	76.7	7.1	0.4	3.2
TOTAL AF	430.0	4,380.0	13,490.0	19,300.0	36,530.0		29,720.0	20,970.0	11,260.0	18,520.0	3,288.0	384.0

### WATER YEAR 1995-1996 (DISCHARGE IN CFS)

MONTH	OCT	NOV	DEC	JAN	FEB	MAR	APR	MAY	JUN	JUL	AUG	SEP
MEAN	172.0	1.4	0.7	1.2	4.3	78.7	165.0	137.0	260.0	135.0	234.0	295.0
MAX	552.0	3.0	1.2	5.8	27.3	109.0	248.0	205.0	424.0	208.0	405.0	518.0
MIN	1.9	1.1	0.4	0.7	0.9	47.6	59.4	8.5	1.2	1.1	8.2	1.5
TOTAL AF	10,590.0	83.0	40.0	74.0	250.0	4,838.0	9,825.0	8,434.0	15,450.0	8,286.0	14,370.0	17,540.0

Note : All figures are in terms of daily amounts, i.e., Mean Daily, Maximum Daily & Minimum Daily.

# LOS ANGELES RIVER below Firestone Boulevard STATION NO. F34D-R

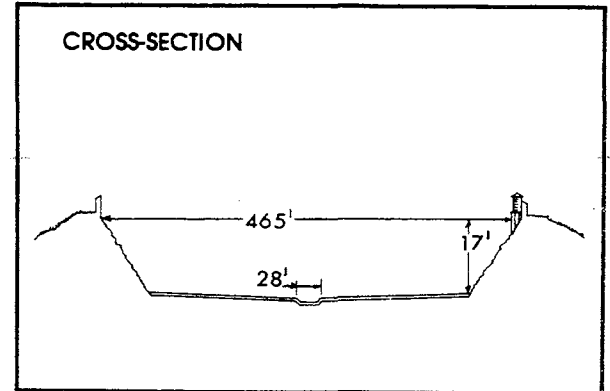
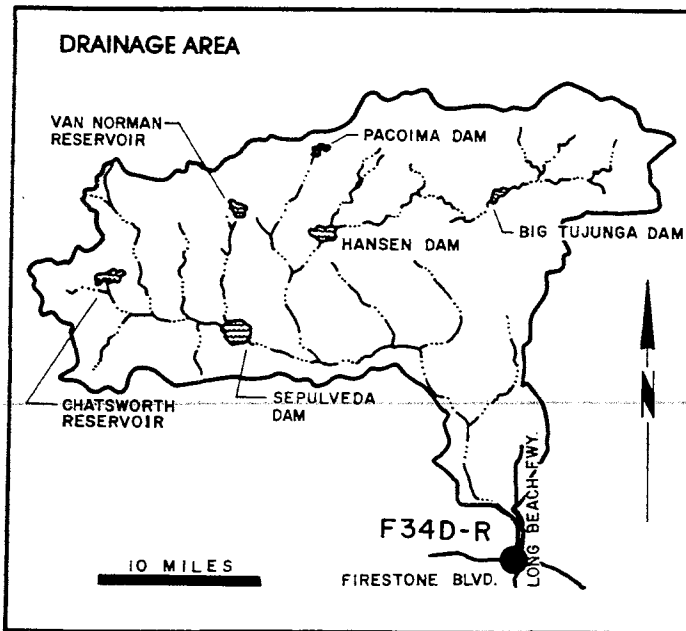
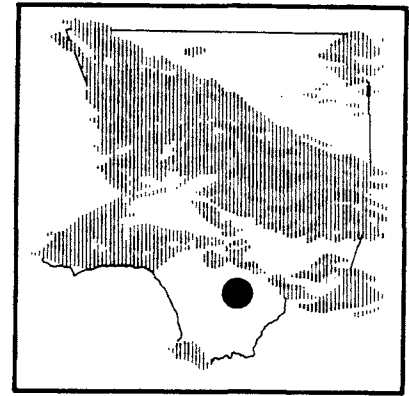

RECORDER- continuous water stage.

METHOD OF MEASUREMENTS- wading or from bridge.

DRAINAGE AREA- 596.0 square miles.

LOCATION- 472.0 feet downstream of Firestone Boulevard 3.0 miles west of Downey.

REGULATION- partially regulated by Sepulveda, Pacoima, Big Tujunga, Hansen, and Devil's Gate Dam; and by several spreading grounds, reservoirs, and debris basins.

CHANNEL- concrete, with rip-rap side slopes, trapezoidal in section, with trapezoidal low-flow channel.

CONTROL- channel forms control.

LENGTH OF RECORD- at Station F34-R March 1, 1928 to April 11, 1938. at Station F34B-R, April 11, 1938 to November 3, 1949. at Station F34C-R November 4, 1949, to December 11, 1956. at Station F34D-R December 11, 1956 to date.

REMARKS- subject to diversions from Big Tujunga Creek, Arroyo Seco, and other domestic and irrigation diversions

## WATER YEAR 1994-1995 (DISCHARGE IN CFS)

MONTH	OCT	NOV	DEC	JAN	FEB	MAR	APR	MAY	JUN	JUL	AUG	SEP
MEAN	163.0	142.0	217.0	2,535.0	337.0	1,362.0	214.0	295.0	172.0	119.0	120.0	115.0
MAX	1,130.0	875.0	1,620.0	24,200.0	4,560.0	17,800.0	1,640.0	2,160.0	1,310.0	124.0	121.0	119.0
MIN	105.0	103.0	106.0	103.0	121.0	131.0	129.0	96.5	117.0	116.0	117.0	111.0
TOTAL AF	10,000.0	8,461.0	13,350.0	155,900.0	18,710.0	83,770.0	12,720.0	18,130.0	10,230.0	7,311.0	7,363.0	6,859.0

## WATER YEAR 1995-1996 (DISCHARGE IN CFS)

MONTH	OCT	NOV	DEC	JAN	FEB	MAR	APR	MAY	JUN	JUL	AUG	SEP
MEAN	113.0	117.0	185.0	275.0	714.0	235.0	128.0	109.0	114.0	104.0	100.0	99.3
MAX	119.0	119.0	1,340.0	4,130.0	9,110.0	1,600.0	361.0	116.0	124.0	109.0	105.0	108.0
MIN	108.0	116.0	115.0	98.4	107.0	107.0	100.0	97.9	104.0	101.0	89.5	87.2
TOTAL AF	6,954.0	6,954.0	11,360.0	16,890.0	41,090.0	14,470.0	7,607.0	6,675.0	6,787.0	6,403.0	6,153.0	5,906.0

Note: All figures are in terms of daily amounts, i.e., Mean Daily, Maximum Daily & Minimum Daily.

# COMPTON CREEK

near Greenleaf Drive  
STATION NO. F37B-R

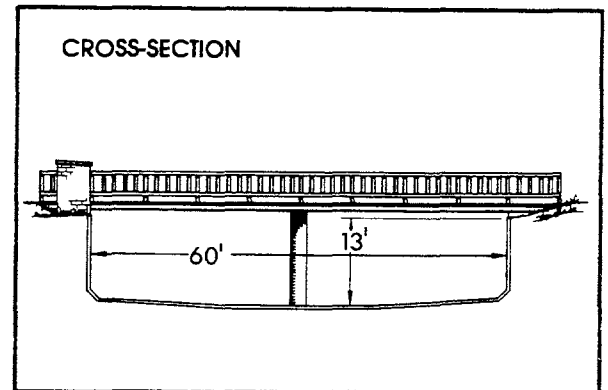
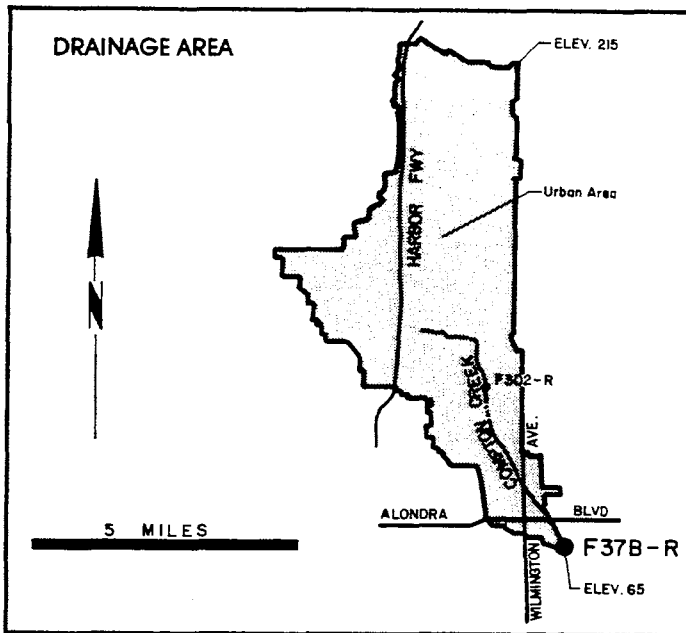
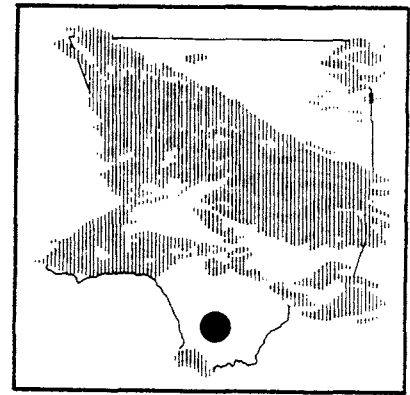

RECORDER- continuous water stage.

METHOD OF MEASUREMENTS- wading or from bridge.

DRAINAGE AREA- 22.6 square miles.

LOCATION- 120.0 feet above Greenleaf Boulevard, 1.5 miles south west of Compton.

REGULATION- none.

CHANNEL- concrete, rectangular in section, 60 feet wide by 13 feet deep.

CONTROL- channel forms control.

LENGTH OF RECORD- at Station F37-R January 22, 1928 to June 9, 1938. at Station F37B-R October 3, 1938 to date

## WATER YEAR 1994-1995 (DISCHARGE IN CFS)

MONTH	OCT	NOV	DEC	JAN	FEB	MAR	APR	MAY	JUN	JUL	AUG	SEP
MEAN	2.1	3.7	8.8	106.0	2.7	51.0	3.7	1.4	4.9	1.0	1.0	0.9
MAX	16.4	56.4	146.0	1,120.0	57.2	481.0	68.7	13.2	86.0	1.2	1.2	0.9
MIN	0.6	0.7	0.8	0.3	0.0	0.5	1.0	0.8	0.8	0.9	0.9	0.9
TOTAL AF	131.0	221.0	543.0	6,488.0	153.0	3,136.0	220.0	88.0	293.0	59.0	59.0	54.0

## WATER YEAR 1995-1996 (DISCHARGE IN CFS)

MONTH	OCT	NOV	DEC	JAN	FEB	MAR	APR	MAY	JUN	JUL	AUG	SEP
MEAN	1.0	1.0	12.1	18.6	40.7	13.2	5.8	1.0	0.9	1.0	0.9	0.9
MAX	2.0	1.2	160.0	426.0	627.0	138.0	92.4	1.2	0.9	1.2	0.9	0.9
MIN	0.8	0.9	0.9	0.8	0.5	0.6	0.7	0.9	0.9	0.8	0.9	0.9
TOTAL AF	59.0	61.0	747.0	1,144.0	2,340.0	814.0	344.0	60.0	54.0	60.0	55.0	54.0

Note : All figures are in terms of daily amounts, i.e., Mean Daily, Maximum Daily & Minimum Daily.

# BALLONA CREEK

## above Sawtelle Boulevard

### STATION NO. F38C-R

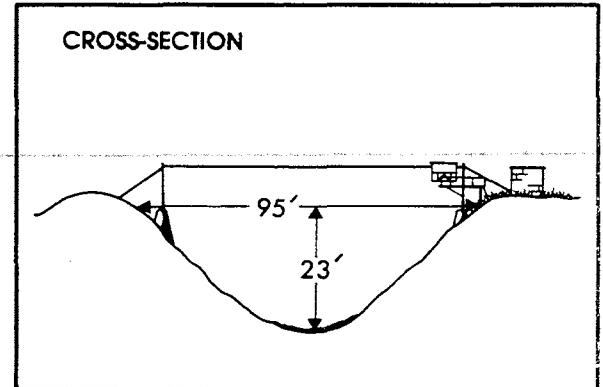
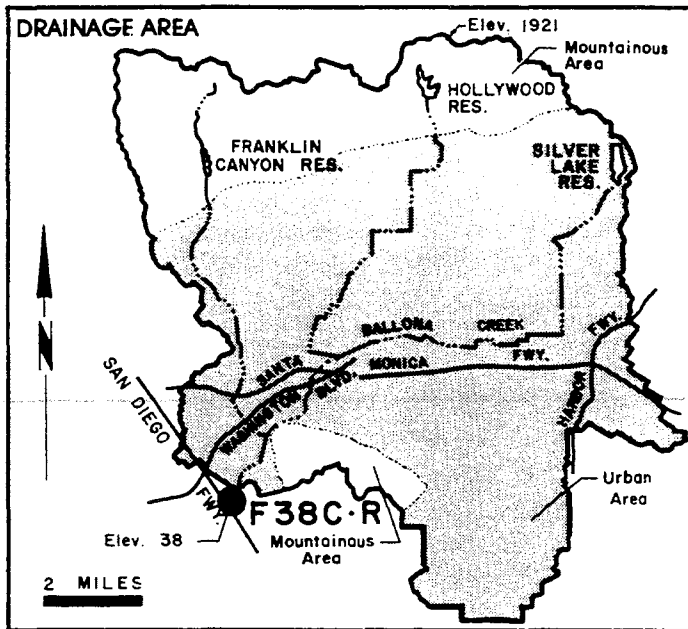
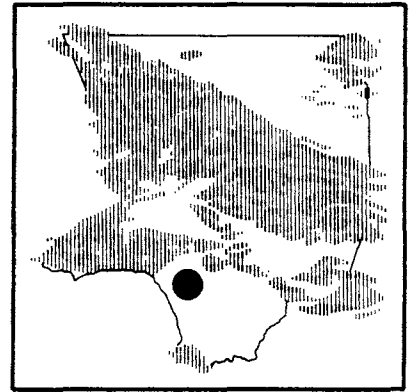

RECORDER- continuous water stage.

METHOD OF MEASUREMENTS- wading or from cable car.

DRAINAGE AREA- 88.6 square miles.

LOCATION- 530.0 feet above Sawtelle Boulevard, 1.5 miles southwest of Culver City.

REGULATION- Stone Canyon Reservoir prior to January, 1951. Upper and Lower Franklin Canyon Reservoir, Hollywood Reservoir, and Silver Lake Reservoir.

CHANNEL- concrete rubble, trapezoidal in section.

CONTROL- channel forms control.

LENGTH OF RECORD- at Station F38-R February 27, 1928 to April 27, 1936. at Station F38B-R, May 14, 1936 to August 10, 1967. at Station F38C-R August 10, 1967, to date.

### WATER YEAR 1994-1995 (DISCHARGE IN CFS)

MONTH	OCT	NOV	DEC	JAN	FEB	MAR	APR	MAY	JUN	JUL	AUG	20.8
MEAN	17.6	25.8	44.3	570.0	80.1	283.0	45.9	38.6	47.2	26.1	24.2	20.8
MAX.	136.0	325.0	633.0	4,680.0	1,060.0	2,250.0	671.0	437.0	450.0	56.6	46.2	23.8
MIN.	9.4	9.6	9.6	11.3	17.6	22.3	19.8	21.8	18.6	16.4	19.6	18.1
TOTAL AF	1,084.0	1,537.0	2,721.0	35,020.0	4,451.0	17,400.0	2,729.0	2,376.0	2,810.0	1,603.0	1,488.0	1,236.0

### WATER YEAR 1995-1996 (DISCHARGE IN CFS)

MONTH	OCT	NOV	DEC	JAN	FEB	MAR	APR	MAY	JUN	JUL	AUG	SEP
MEAN	20.6	26.1	63.3	86.2	228.0	93.0	44.8	23.9	15.8	16.6	15.0	14.8
MAX.	25.1	47.0	574.0	1,460.0	2,930.0	962.0	315.0	46.7	23.1	19.2	17.9	17.7
MIN.	16.5	17.1	13.2	13.0	12.6	15.3	17.7	16.2	12.0	14.9	12.8	13.3
TOTAL AF	1,267.0	1,556.0	3,892.0	5,299.0	13,100.0	5,717.0	2,667.0	1,470.0	940.0	1,023.0	923.0	883.0

Note : All figures are in terms of daily amounts, i.e., Mean Daily, Maximum Daily & Minimum Daily.

# SAN GABRIEL RIVER above Spring Street STATION NO. F42B-R

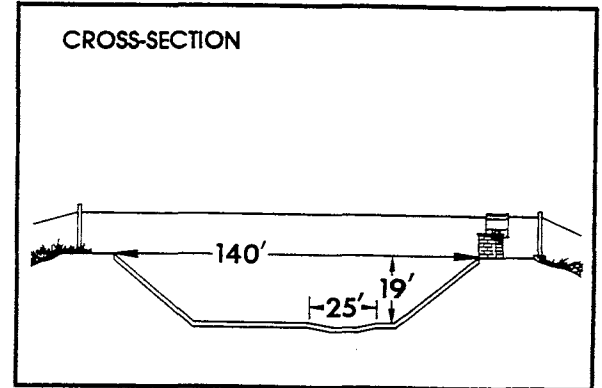
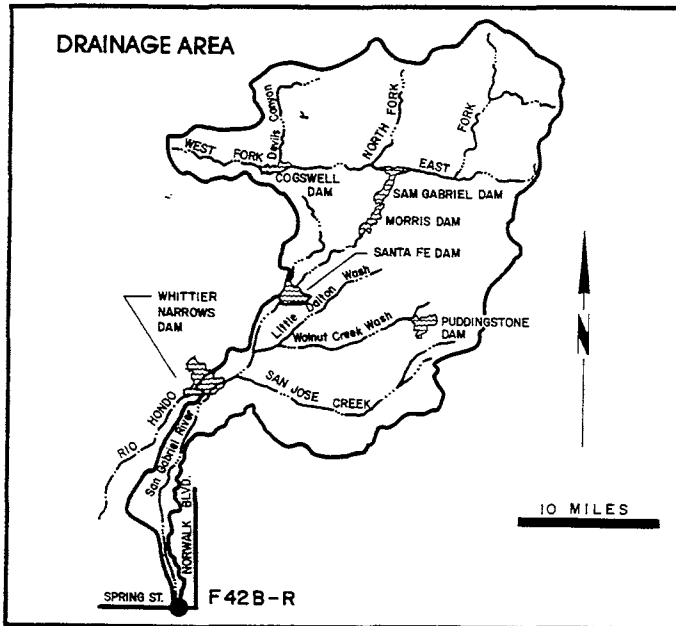
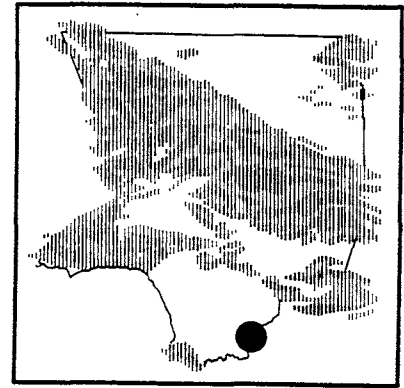

RECORDER- continuous water stage.

METHOD OF MEASUREMENTS- wading or from cable car.

DRAINAGE AREA- 231.0 square miles (excludes area above Santa Fe Dam).

LOCATION- 455.0 feet north of Spring Street, 4.0 miles east of Signal Hill, Long Beach.

REGULATION - partially regulated by Cogswell, San Gabriel, Morris, Santa Fe, Big Dalton, San Dimas, Puddingstone Diversion, Puddingstone, Live Oak, Thompson Creek, and Whittier Narrows Dams, several debris basins, MWD outlet, and several spreading grounds.

CHANNEL- concrete, trapezoidal section with a low-flow channel.

CONTROL- channel forms control.

LENGTH OF RECORD- at Station F42-R February 6, 1928 to May 26, 1964. at Station F42B-R, November 16, 1964 to date.

REMARKS- high flows into Whittier Narrows Reservoir are partially diverted to the Rio Hondo.

## WATER YEAR 1994-1995 (DISCHARGE IN CFS)

MONTH	OCT	NOV	DEC	JAN	FEB	MAR	APR	MAY	JUN	JUL	AUG	SEP
MEAN	132.0	123.0	155.0	217.0	163.0	589.0	124.0	120.0	107.0	84.8	116.0	141.0
MAX.	166.0	167.0	567.0	617.0	809.0	3,230.0	177.0	133.0	197.0	118.0	287.0	210.0
MIN	118.0	94.4	113.0	110.0	107.0	106.0	95.6	104.0	92.0	57.6	33.3	113.0
TOTAL AF	8,108.0	7,338.0	9,529.0	13,320.0	9,053.0	36,230.0	7,354.0	7,375.0	6,354.0	5,212.0	7,153.0	8,366.0

## WATER YEAR 1995-1996 (DISCHARGE IN CFS)

MONTH	OCT	NOV	DEC	JAN	FEB	MAR	APR	MAY	JUN	JUL	AUG	SEP
MEAN	142.0	64.1	77.0	97.8	171.0	*	NO	77.4	54.9	115.0	114.0	176.0
MAX.	160.0	113.0	203.0	476.0	1,120.0	*	DATA	139.0	77.7	218.0	191.0	249.0
MIN	118.0	25.8	43.8	46.9	40.5	*		37.2	34.2	37.6	56.2	73.8
TOTAL AF	8,707.0	3,812.0	4,732.0	6,012.0	9,833.0	*		4,759.0	3,269.0	7,057.0	6,759.0	10,470.0

LEGEND \* - Recorder malfunctioned during part of the month. Partial data is available.

Note : All figures are in terms of daily amounts, i.e., Mean Daily, Maximum Daily & Minimum Daily.

# RIO HONDO

## above Stewart and Gray Road

### STATION NO. F45B-R

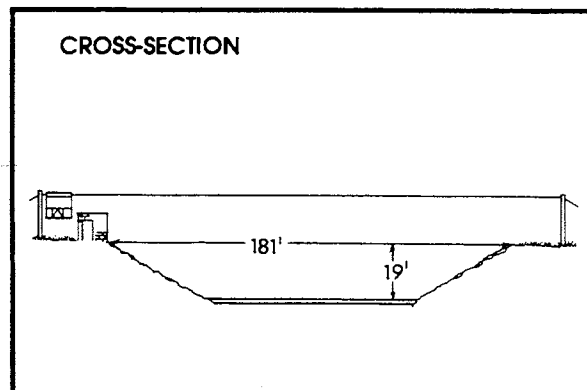
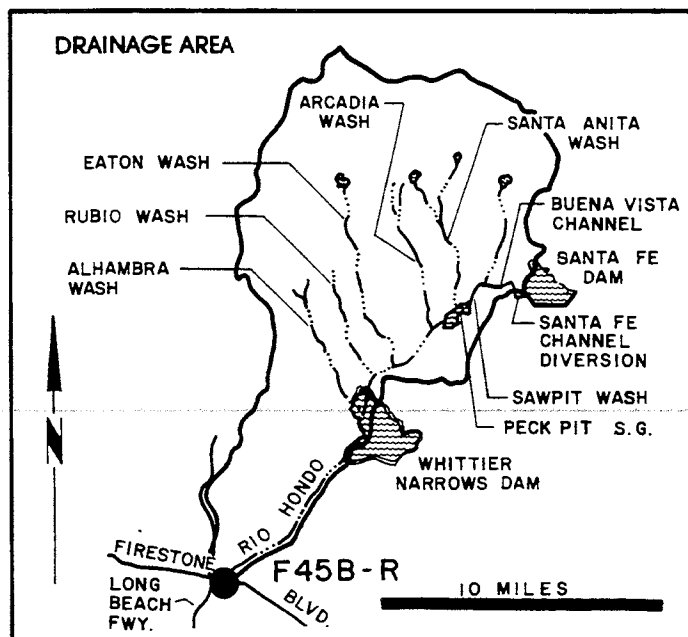
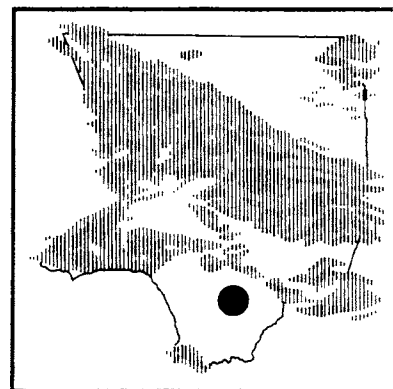

RECORDER- continuous water stage.

METHOD OF MEASUREMENTS- wading or from cable car.

DRAINAGE AREA- 140 square miles (excludes area above Santa Fe Dam).

LOCATION- 0.6 mile upstream of the confluence of Rio Hondo and Los Angeles River, 1.5 miles west of Downey.

REGULATION- partially regulated by Sierra Madre, Santa Anita, Sawpit, Eaton, Santa Fe, and Whittier Narrows Dams, several debris basins, and spreading grounds.

CHANNEL - concrete with rip-rap side slopes. Trapezoidal in section.

CONTROL- channel forms control.

LENGTH OF RECORD- at Station F45-R March 1, 1928 to April 18, 1951. at Station F45B-R October 31, 1951 to date.

REMARKS- subject to diversions from Eaton Creek, Monrovia Creek, Sawpit Creek, Little Santa Anita Canyon and other locations for irrigation and spreading. High flows from San Gabriel River may flow into Rio Hondo above Whittier Narrows Dam.

### WATER YEAR 1994-1995 (DISCHARGE IN CFS)

MONTH	OCT	NOV	DEC	JAN	FEB	MAR	APR	MAY	JUN	JUL	AUG	SEP
MEAN	3.3	2.5	5.9	895.0	101.0	891.0	10.8	1.0	36.0	0.2	0.2	0.7
MAX.	57.4	41.5	94.0	10,500.0	1,320.0	7,260.0	262.0	4.1	1,040.0	1.0	0.6	3.2
MIN	0.6	0.1	0.1	0.2	0.7	0.5	0.2	0.5	0.4	0.1	0.1	0.1
TOTAL AF	205.0	151.0	363.0	55,030.0	5,598.0	54,810.0	641.0	62.0	2,141.0	14.0	12.0	41.0

### WATER YEAR 1995-1996 (DISCHARGE IN CFS)

MONTH	OCT	NOV	DEC	JAN	FEB	MAR	APR	MAY	JUN	JUL	AUG	SEP
MEAN	0.6	0.6	7.3	82.0	359.0	40.6	5.4	0.3	0.3	0.5	1.2	1.3
MAX.	1.0	2.6	122.0	2,330.0	6,320.0	696.0	44.7	1.8	1.1	1.4	1.6	1.7
MIN	0.4	0.1	0.0	0.1	0.1	0.1	0.1	0.1	0.1	0.1	0.7	1.2
TOTAL AF	38.0	35.0	451.0	5,043.0	20,640.0	2,495.0	318.0	16.0	20.0	34.0	72.0	79.0

Note : All figures are in terms of daily amounts, i.e., Mean Daily, Maximum Daily & Minimum Daily.

# RIO HONDO above Mission Bridge STATION NO. F64-R

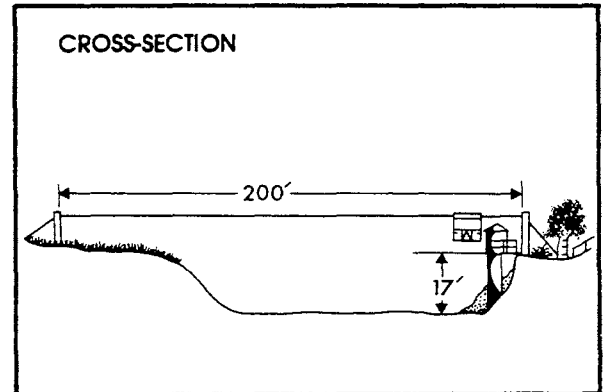
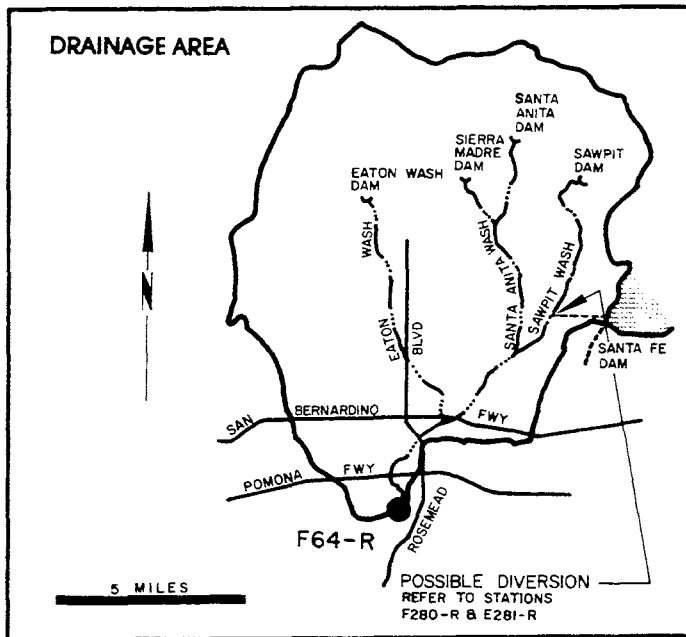
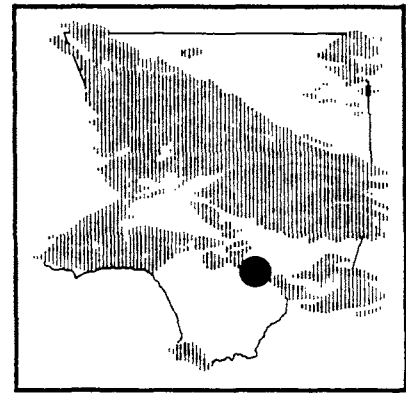

RECORDER- continuous water stage.

METHOD OF MEASUREMENTS- wading or from cable car.

DRAINAGE AREA- 115 square miles (excludes area above Santa Fe Dam).

LOCATION- 1,000 feet above San Gabriel Boulevard, west of Rosemead Boulevard, 2.0 miles northeast of Montebello.

REGULATION- partially regulated by Sierra Madre, Santa Anita, Sawpit, Eaton, and Santa Fe Dams and several debris basins.

CHANNEL- sand and silt, natural in section.

CONTROL- none.

LENGTH OF RECORD- July 1, 1928 to date.

REMARKS- subject to diversions; water purchased from the MWD passes this station for spreading in the coastal basin.

## WATER YEAR 1994-1995 (DISCHARGE IN CFS)

MONTH	OCT	NOV	DEC	JAN	FEB	MAR	APR	MAY	JUN	JUL	AUG	SEP
MEAN	44.8	45.7	69.1	*	70.3	320.0	24.2	6.1	23.8	5.9	5.0	4.3
MAX.	227.0	296.0	257.0	*	840.0	3,960.0	272.0	11.0	500.0	7.4	7.9	6.7
MIN.	27.2	28.6	4.2	*	7.8	9.6	2.3	3.8	4.7	3.5	2.9	2.8
TOTAL AF	2,752.0	2,722.0	4,250.0	*	3,902.0	19,670.0	1,438.0	375.0	1,418.0	363.0	308.0	256.0

## WATER YEAR 1995-1996 (DISCHARGE IN CFS)

MONTH	OCT	NOV	DEC	JAN	FEB	MAR	APR	MAY	JUN	JUL	AUG	SEP
MEAN	86.9	22.1	14.4									
MAX.	223.0	27.7	114.0									
MIN.	0.9	1.6	1.7									
TOTAL AF	5344.0	1317.0	887.0									

THE STATION HAD BEEN DISCONTINUED

LEGEND \* - Data inaccurate due to back water condition. Partial data is available.

Note: All figures are in terms of daily amounts, i.e., Mean Daily, Maximum Daily & Minimum Daily.



# ALHAMBRA WASH

near Klingerman Street  
STATION NO. F81D-R

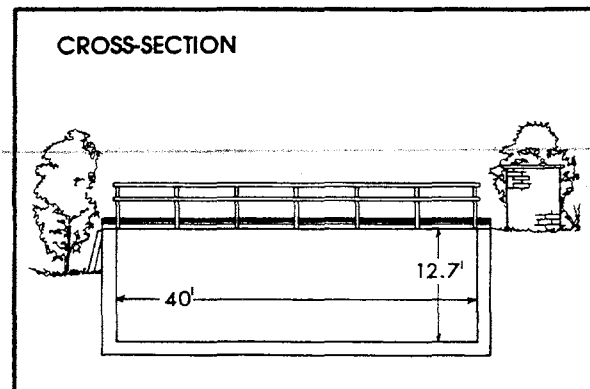
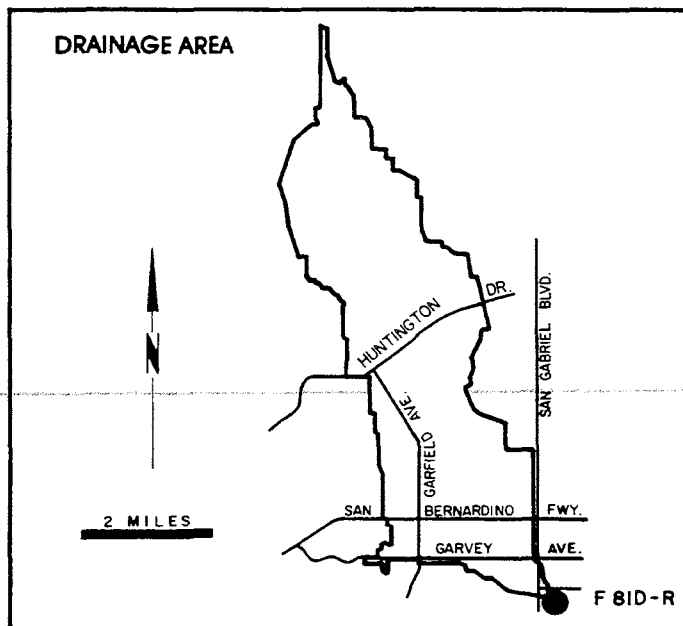
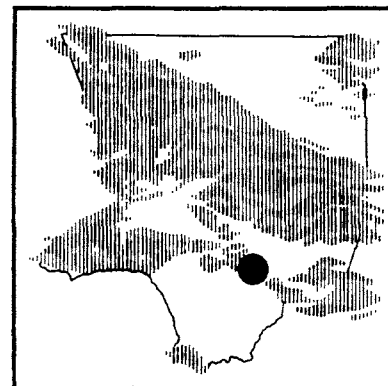

RECORDER- continuous water stage.

METHOD OF MEASUREMENTS- wading or from footbridge.

DRAINAGE AREA- 15.2 square miles.

LOCATION- 250± feet above Klingerman Street and 2,650.0 feet below Garvey Avenue, South San Gabriel.

REGULATION- none.

CHANNEL- concrete, rectangular in section, 40.0 feet wide by 12.7 feet deep.

CONTROL- channel forms control.

LENGTH OF RECORD- at Station F81- R January 14, 1930 to September 30, 1934. at Station F81B- R October 1, 1934 to February 25, 1935. at Station F81C- R February 25, 1935 to April 27, 1936. at Station F81B- R April 27, 1936 to May 22, 1936. at Station F81D- R September 2, 1936 to date.

## WATER YEAR 1994-1995 (DISCHARGE IN CFS)

MONTH	OCT	NOV	DEC	JAN	FEB	MAR	APR	MAY	JUN	JUL	AUG	SEP
MEAN	5.5	4.2	5.0	80.9	10.8	48.4	5.3	1.9	6.2	0.8	0.6	0.9
MAX	73.9	59.2	64.5	875.0	186.0	501.0	96.7	6.1	119.0	2.2	1.2	1.2
MIN	2.1	1.1	1.1	1.2	1.2	1.6	1.2	0.8	1.6	0.2	0.4	0.7
TOTAL AF	337.0	251.0	306.0	4,975.0	600.0	2,974.0	315.0	119.0	368.0	48.0	37.0	53.0

## WATER YEAR 1995-1996 (DISCHARGE IN CFS)

MONTH	OCT	NOV	DEC	JAN	FEB	MAR	APR	MAY	JUN	JUL	AUG	SEP
MEAN	1.0	1.8	*7.0	19.3	29.7	10.9	5.6	3.7	3.0	1.2	1.6	1.6
MAX	2.8	9.9	*68.8	410.0	462.0	133.0	55.5	11.4	4.1	2.0	2.1	3.3
MIN	0.6	0.7	*0.4	1.0	0.8	0.6	1.2	1.3	1.1	0.4	1.3	1.1
TOTAL AF	60.0	105.0	*320	1,189.0	1,706.0	672.0	330.0	226.0	181.0	75.0	97.0	94.0

LEGEND \* - Data was estimated.

Note : All figures are in terms of daily amounts, i.e., Mean Daily, Maximum Daily & Minimum Daily.

# RUBIO WASH at Glendon Wash STATION NO. F82C-R

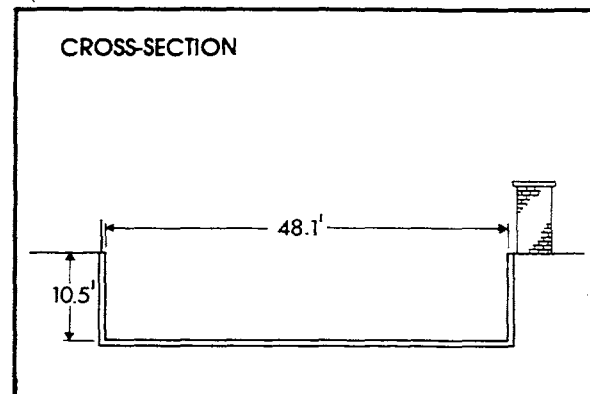
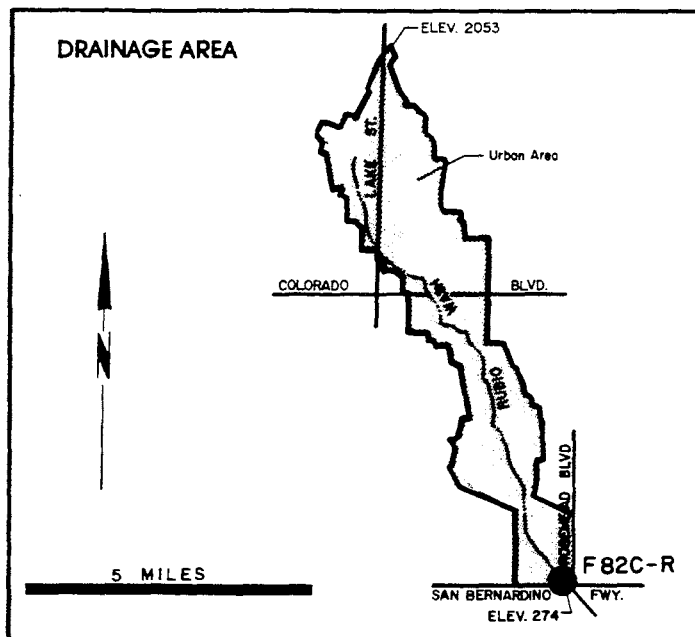
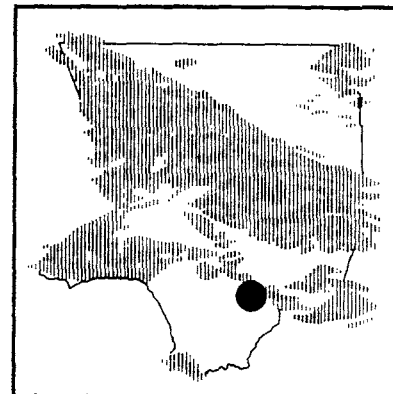

RECORDER- 15 minute punched tape.

METHOD OF MEASUREMENTS- low flows measured by wading. High flows measured from footbridge at station.

DRAINAGE AREA- 10.9 square miles.

LOCATION- on the east side of channel, 10 feet south of the westerly extension of Glendon Way, Rosemead.

REGULATION- flow partly regulated by Las Flores and Rubio debris basins.

CHANNEL- rectangular concrete.

CONTROL- channel forms control.

LENGTH OF RECORD- see station summary.

## WATER YEAR 1994-1995 (DISCHARGE IN CFS)

MONTH	OCT	NOV	DEC	JAN	FEB	MAR	APR	MAY	JUN	JUL	AUG	SEP
MEAN	1.5	1.5	2.4	57.9	8.5	30.2	3.9	0.3	4.6	0.2	0.2	0.2
MAX	27.1	31.5	45.6	707.0	189.0	299.0	86.3	1.3	112.0	0.4	0.3	0.3
MIN	0.0	0.1	0.1	0.1	0.1	0.0	0.0	0.1	0.1	0.2	0.1	0.2
TOTAL AF	92.0	89.0	148.0	3,561.0	470.0	1,858.0	230.0	15.0	273.0	15.0	12.0	12.0

## WATER YEAR 1995-1996 (DISCHARGE IN CFS)

MONTH	OCT	NOV	DEC	JAN	FEB	MAR	APR	MAY	JUN	JUL	AUG	SEP
MEAN	0.2	0.2	3.7	13.5	66.2	7.9	0.9	0.2	0.1	0.1	0.1	0.0
MAX	0.6	1.5	52.7	311.0	656.0	149.0	9.9	0.4	0.3	0.3	0.3	0.1
MIN	0.1	0.1	0.1	0.1	0.2	0.1	0.0	0.1	0.1	0.0	0.0	0.0
TOTAL AF	14.0	10.0	226.0	829.0	3,810.0	487.0	55.0	10.0	9.0	7.0	5.0	2.0

Note : All figures are in terms of daily amounts, i.e., Mean Daily, Maximum Daily & Minimum Daily.

# SANTA CLARA RIVER

## below Highway 5

### STATION NO. F92C-R

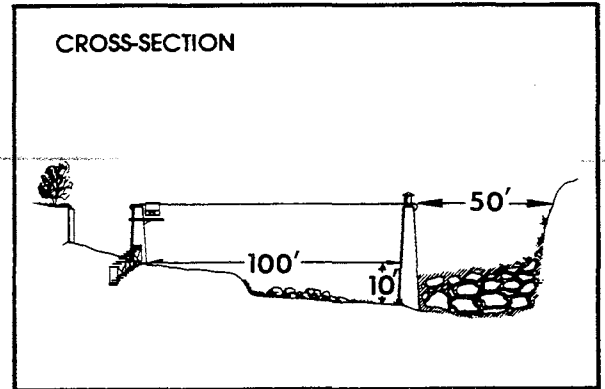
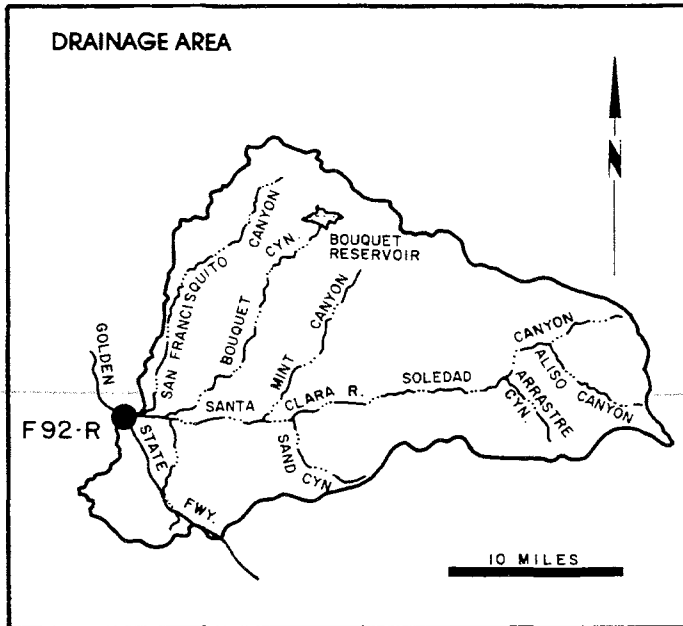
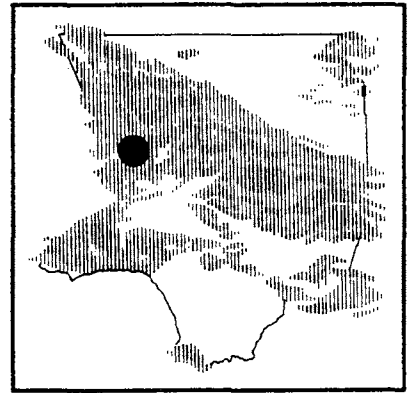

RECORDER- continuous water stage.

METHOD OF MEASUREMENTS- wading or from cable car.

DRAINAGE AREA- 410.4 square miles.

LOCATION- downstream side of Old Highway bridge, 3.0 miles west of Saugus.

REGULATION- partially regulated by Bouquet Canyon and Dry Canyon Reservoirs.

CHANNEL- sand and gravel with brush, natural section.

CONTROL- none

LENGTH OF RECORD- at Station F92-R January 18, 1930 to March 28, 1938, and September 24, 1956 to date. at Station F92B-R, October 1, 1938 to September 24, 1956.

REMARKS- subject to diversions for irrigation.

### WATER YEAR 1994-1995 (DISCHARGE IN CFS)

MONTH	OCT	NOV	DEC	JAN	FEB	MAR	APR	MAY	JUN	JUL	AUG	SEP
MEAN	13.2	13.5	26.6	447.0	37.6	*	*	*	*	*	*	*
MAX.	13.2	14.3	103.0	2,180.0	188.0	*	*	*	*	*	*	*
MIN	13.2	12.9	13.2	17.4	4.4	*	*	*	*	*	*	*
TOTAL AF	812.0	802.0	1,635.0	27,470.0	2,091.0	*	*	*	*	*	*	*

### WATER YEAR 1995-1996 (DISCHARGE IN CFS)

MONTH	OCT	NOV	DEC	JAN	FEB	MAR	APR	MAY	JUN	JUL	AUG	SEP
MEAN												
MAX.	THE STATION HAD BEEN DISCONTINUED											
MIN												
TOTAL AF												

LEGEND\*-Recorder has been vandalized since March 1995.

Note : All figures are in terms of daily amounts, i.e., Mean Daily, Maximum Daily & Minimum Daily.

# PALLETT CREEK at Valyermo Highway STATION NO. F122-R

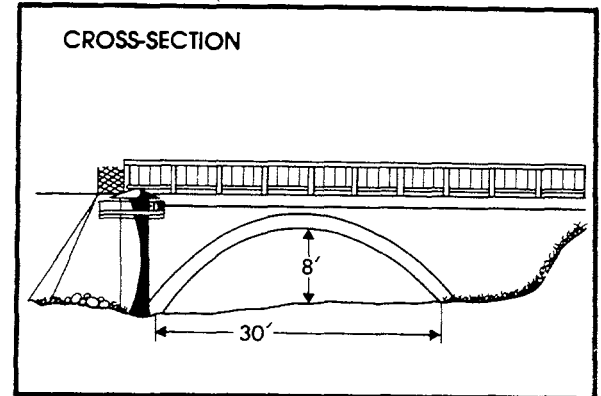
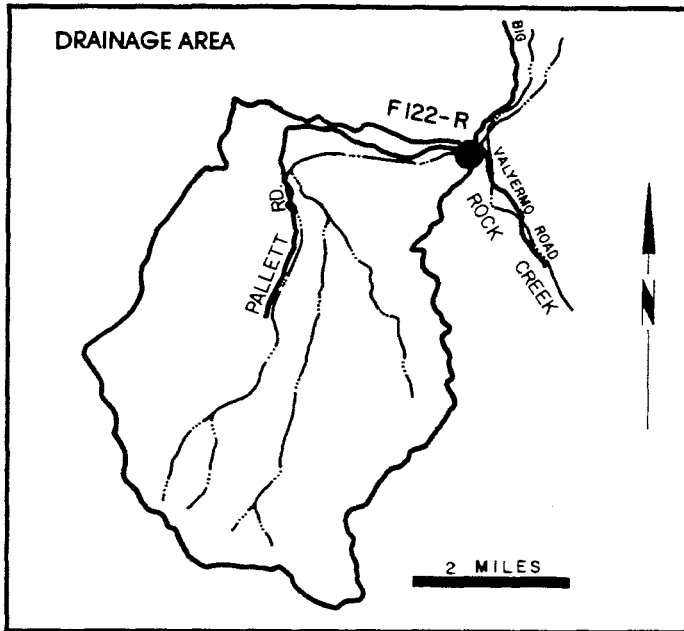
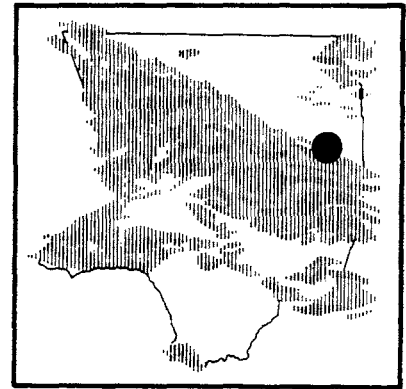

**RECORDER-** continuous water stage.  
**METHOD OF MEASUREMENTS-** wading or from bridge.  
**DRAINAGE AREA-** 15.8 square miles.  
**LOCATION-** upstream side of Valyermo Highway bridge, 5.0 miles southeast of Pearblossom.  
**REGULATION-** none.  
**CHANNEL-** sand and gravel, natural section.  
**CONTROL-** channel forms control for low flows; bridge culvert forms control for high flows.  
**LENGTH OF RECORD-** at Station F122-S December 29, 1930 to October 31, 1961. at Station F122-R, October 31, 1961 to date.

## WATER YEAR 1994-1995 (DISCHARGE IN CFS)

MONTH	OCT	NOV	DEC	JAN	FEB	MAR	APR	MAY	JUN	JUL	AUG	SEP
MEAN	0.3	0.2	0.3	25.7	1.6	25.1	12.2	6.2	3.8	2.8	1.3	1.4
MAX	0.3	0.3	0.3	133.0	12.6	116.0	21.9	8.4	4.3	4.2	2.0	1.5
MIN	0.3	0.2	0.3	0.0	1.0	0.5	8.4	4.2	3.2	2.0	1.0	1.0
TOTAL AF	18.0	13.0	18.0	1,581.0	87.0	1,542.0	727.0	379.0	229.0	174.0	82.0	84.0

## WATER YEAR 1995-1996 (DISCHARGE IN CFS)

MONTH	OCT	NOV	DEC	JAN	FEB	MAR	APR	MAY	JUN	JUL	AUG	SEP
MEAN	0.9	1.2	1.1	1.3	0.7	0.8	0.8	0.8	0.2	0.4	0.4	0.3
MAX	0.9	1.2	1.2	1.6	0.8	0.9	0.9	0.8	0.6	0.6	0.4	0.4
MIN	0.9	1.2	0.9	0.8	0.6	0.8	0.7	0.6	0.0	0.4	0.3	0.2
TOTAL AF	55.0	71.0	65.0	79.0	41.0	51.0	47.0	46.0	13.0	25.0	23.0	16.0

Note : All figures are in terms of daily amounts, i.e., Mean Daily, Maximum Daily & Minimum Daily.

# SANTIAGO CREEK

## above Little Rock Creek

### STATION NO. F125-R

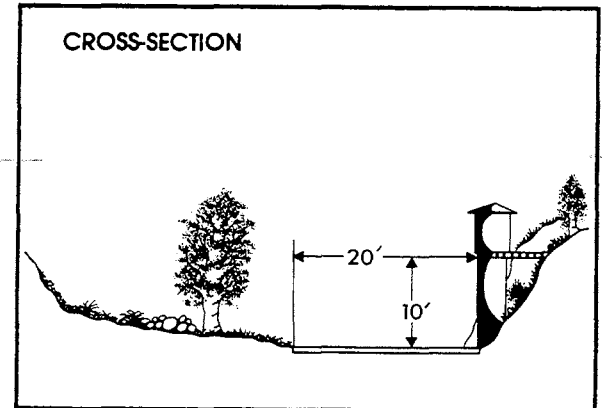
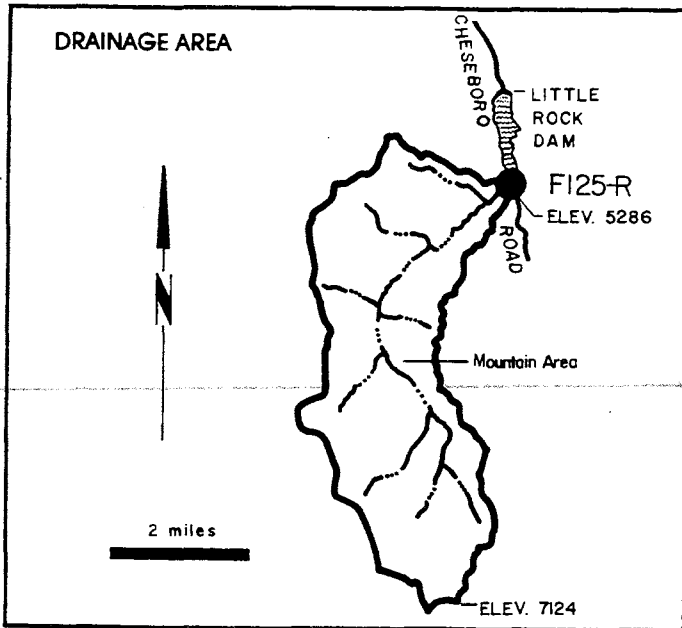
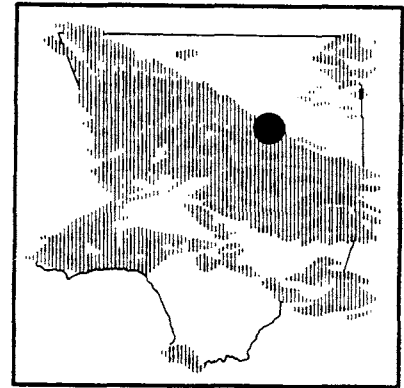

RECORDER- continuous water stage.  
 METHOD OF MEASUREMENTS- wading.  
 DRAINAGE AREA- 11.2 square miles.  
 LOCATION- 1,000 feet above Little Creek and 4.5 miles south of Little Rock.  
 REGULATION- none.  
 CHANNEL- sand, gravel and boulders.  
 CONTROL- concrete and rubble wall.  
 LENGTH OF RECORD- September 29, 1953 to date.  
 REMARKS- no high flow measurements.

#### WATER YEAR 1994-1995 (DISCHARGE IN CFS)

MONTH	OCT	NOV	DEC	JAN	FEB	MAR	APR	MAY	JUN	JUL	AUG	SEP
MEAN	0.0	0.0	0.0	3.1	2.8	11.3	3.7	1.4	0.4	0.0	0.2	0.0
MAX	0.0	0.0	0.0	17.2	3.9	76.5	4.6	2.0	1.6	0.0	4.6	0.0
MIN	0.0	0.0	0.0	0.0	2.3	0.1	2.2	0.7	0.0	0.0	0.0	0.0
TOTAL AF	0.0	0.0	0.0	188.0	155.0	694.0	219.0	88.0	24.0	0.0	11.0	0.0

#### WATER YEAR 1995-1996 (DISCHARGE IN CFS)

MONTH	OCT	NOV	DEC	JAN	FEB	MAR	APR	MAY	JUN	JUL	AUG	SEP
MEAN	0.0	0.0	0.0	0.0	1.5	3.6	0.4	0.0	0.0	0.0	0.0	0.0
MAX	0.0	0.0	0.0	0.1	17.3	55.6	0.9	0.1	0.0	0.0	0.0	0.0
MIN	0.0	0.0	0.0	0.0	0.1	0.7	0.1	0.0	0.0	0.0	0.0	0.0
TOTAL AF	0.0	0.0	0.0	1.0	89.0	222.0	23.0	1.0	0.0	0.0	0.0	0.0

Note : All figures are in terms of daily amounts, i.e., Mean Daily, Maximum Daily & Minimum Daily.

# MALIBU CREEK

## below Cold Creek

### STATION NO. F130B-R

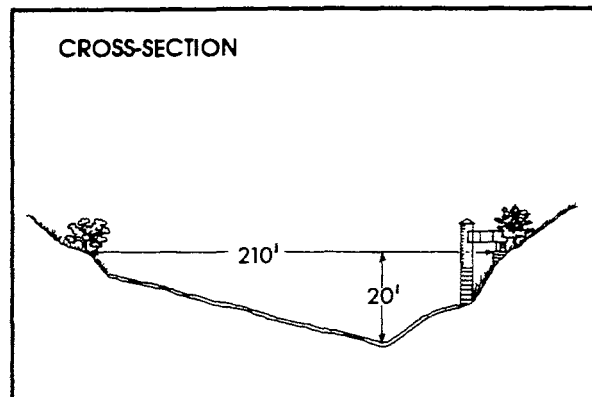
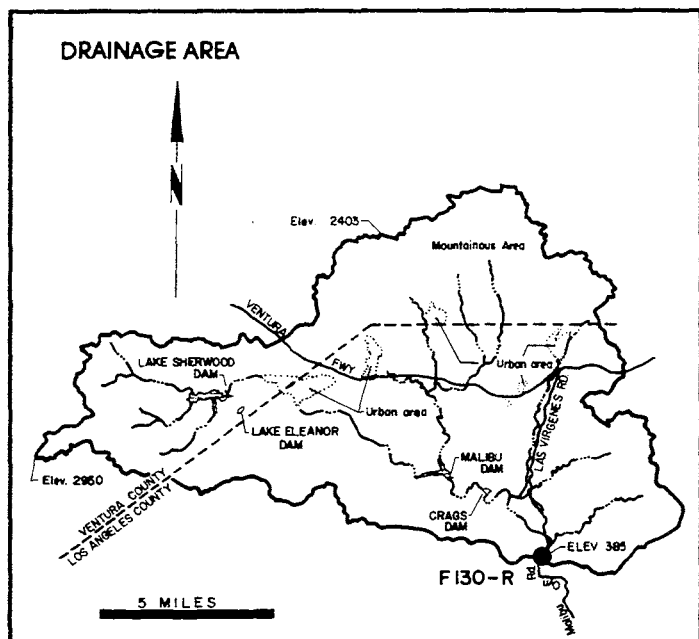
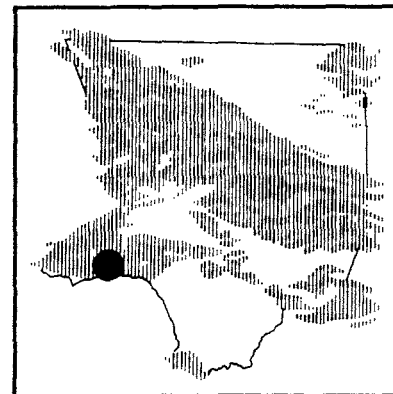

RECORDER- continuous water stage.

METHOD OF MEASUREMENTS- wading or from cable car.

DRAINAGE AREA- 104.96 square miles

LOCATION- 0.2± mile downstream of Cold Creek, 6.0 miles southwest of Calabasas.

REGULATION- Lake Sherwood Dam, Lake Eleanor Dam, Malibu Lake Dam, and Crag's Dam. Other small recreational dams affect low summer flows.

CHANNEL- coarse sand and gravel, lined with trees and brush, natural in section.

CONTROL- concrete stabilizer.

LENGTH OF RECORD- January 17, 1931 to date.

REMARKS- cableway washed out on January 25, 1969; no high flow measurements since that date.

### WATER YEAR 1994-1995 (DISCHARGE IN CFS)

MONTH	OCT	NOV	DEC	JAN	FEB	MAR	APR	MAY	JUN	JUL	AUG	SEP
MEAN	6.3	10.0	11.2	410.0	144.0	353.0	55.8	34.0	*	7.0	5.1	4.9
MAX.	8.9	18.5	32.5	4,530.0	543.0	2,910.0	93.3	116.0	*	8.3	6.7	7.9
MIN	3.1	5.3	7.6	9.7	90.5	99.1	36.9	15.8	*	5.8	4.4	3.7
TOTAL AF	387.0	593.0	686.0	25,210.0	7,984.0	21,690.0	3,319.0	2,089.0	*	428.0	313.0	291.0

### WATER YEAR 1995-1996 (DISCHARGE IN CFS)

MONTH	OCT	NOV	DEC	JAN	FEB	MAR	APR	MAY	JUN	JUL	AUG	SEP
MEAN	4.6	4.5	9.1	9.8	66.8	35.3	6.0	3.0	3.2	5.0	5.3	5.0
MAX.	10.7	6.2	73.5	106.0	637.0	216.0	14.8	5.6	8.5	9.5	8.3	8.6
MIN	1.5	2.6	3.0	2.9	5.8	11.8	2.6	2.2	2.4	3.3	4.2	4.0
TOTAL AF	285.0	268.0	559.0	605.0	3,842.0	2,171.0	356.0	187.0	191.0	307.0	326.0	298.0

LEGEND \* - Recorder malfunction during part of month. Partial data is available.

Note : All figures are in terms of daily amounts, i.e., Mean Daily, Maximum Daily & Minimum Daily.

# MONTEBELLO STORM DRAIN

## above Rio Hondo

### STATION NO. F181-R

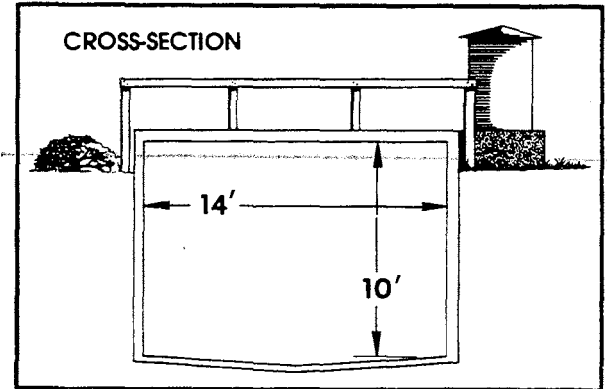
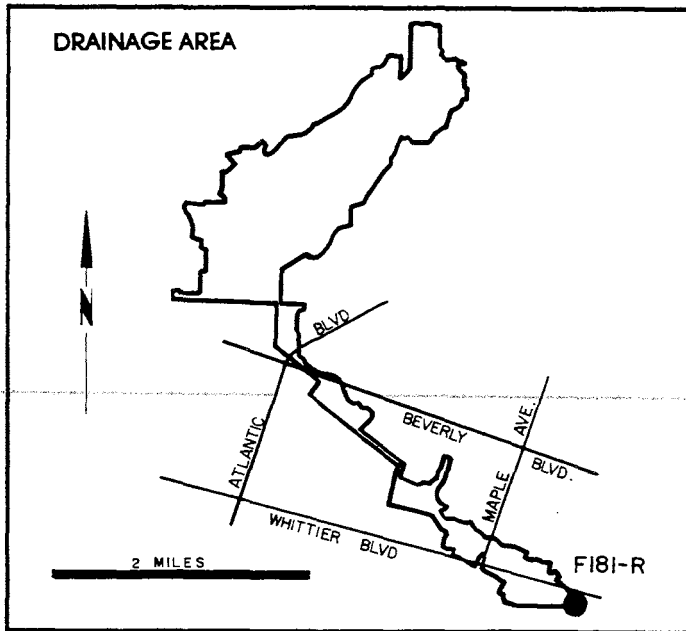

RECORDER- continuous water stage.  
 METHOD OF MEASUREMENTS- wading or from footbridge.  
 DRAINAGE AREA- 9.6 square miles.  
 LOCATION- 150.0 feet east of Mines Avenue and 500.0 feet west of Rio Hondo.  
 REGULATION- none.  
 CHANNEL- 14.0-foot by 10.0-foot concrete, box section.  
 CONTROL- channel forms control.  
 LENGTH OF RECORD- January 12, 1932 to date.  
 REMARKS- may be affected by backwater during flood flows.

### WATER YEAR 1994-1995 (DISCHARGE IN CFS)

MONTH	OCT	NOV	DEC	JAN	FEB	MAR	APR	MAY	JUN	JUL	AUG	SEP
MEAN	0.3	0.5	0.7	13.5	3.4	12.7	2.9	2.4	3.8	2.3	2.6	2.7
MAX	3.0	7.3	10.5	121.0	26.0	131.0	28.8	5.5	32.5	2.7	3.2	6.7
MIN	0.0	0.0	0.0	0.0	1.8	1.8	1.8	1.8	2.1	2.0	2.2	2.4
TOTAL AF	17.0	30.0	40.0	827.0	191.0	779.0	173.0	148.0	229.0	141.0	160.0	160.0

### WATER YEAR 1995-1996 (DISCHARGE IN CFS)

MONTH	OCT	NOV	DEC	JAN	FEB	MAR	APR	MAY	JUN	JUL	AUG	SEP
MEAN	2.2	1.9	0.0	2.0	6.2	0.7	0.4	0.0	0.0	0.0	0.0	0.0
MAX	2.5	3.0	0.1	46.9	134.0	8.2	6.3	0.1	0.0	0.1	0.1	0.0
MIN	2.0	0.0	0.0	0.0	0.0	0.0	0.0	0.0	0.0	0.0	0.0	0.0
TOTAL AF	137.0	112.0	0.0	121.0	355.0	45.0	21.0	0.0	0.0	0.0	0.0	0.0

Note : All figures are in terms of daily amounts, i.e., Mean Daily, Maximum Daily & Minimum Daily.

# SAN GABRIEL RIVER at Foothill Boulevard STATION NO. F190-R

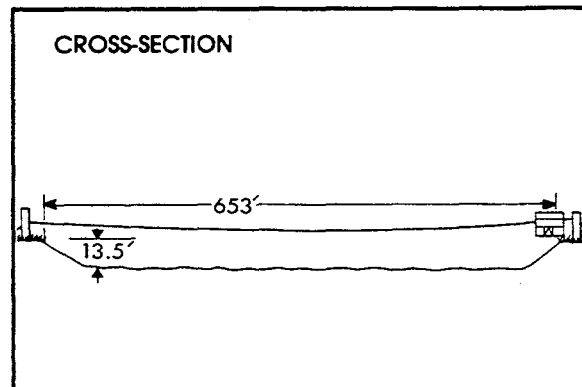
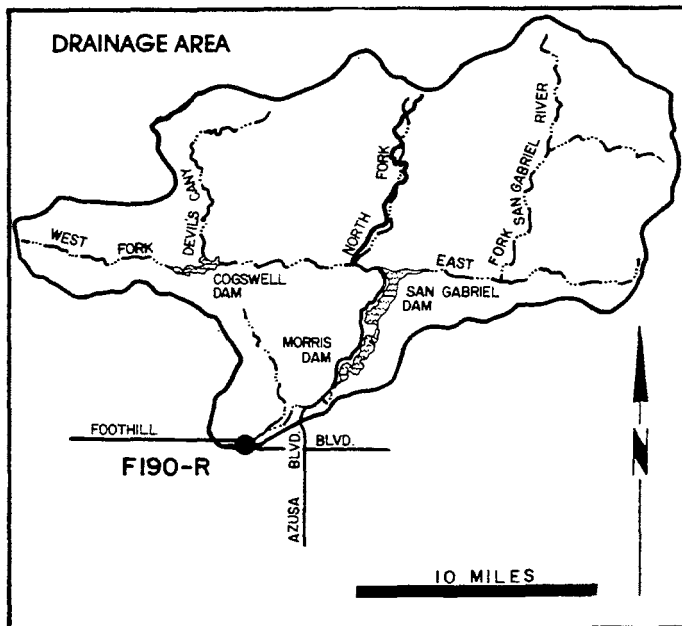
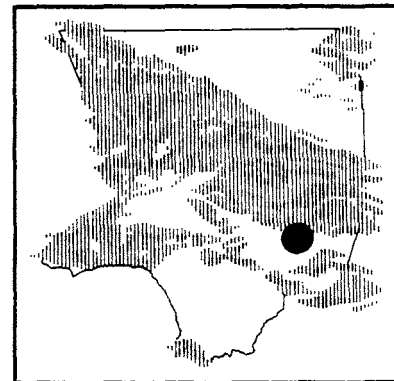

**RECORDER-** continuous water stage.  
**METHOD OF MEASUREMENTS-** wading or from cable car.  
**DRAINAGE AREA-** 230.0 square miles.  
**LOCATION-** downstream side of Foothill Boulevard bridge, 2.0 miles west of Azusa.  
**REGULATION-** partially regulated by Cogswell, San Gabriel, and Morris Dams.  
**CHANNEL-** sand, gravel and rock, trapezoidal section with soft bottom.  
**CONTROL-** gunited rock stabilizers.  
**LENGTH OF RECORD-** February 22, 1932 to date.  
**REMARKS -** flows may include imported water originating at the Metropolitan Water District outlet below Morris Dam.

## WATER YEAR 1994-1995 (DISCHARGE IN CFS)

MONTH	OCT	NOV	DEC	JAN	FEB	MAR	APR	MAY	JUN	JUL	AUG	SEP
MEAN	20.1	35.1	149.0	285.0	560.0	1,127.0	462.0	280.0	137.0	236.0	53.3	0.0
MAX	56.5	367.0	575.0	1,560.0	1,200.0	2,180.0	551.0	647.0	367.0	562.0	196.0	0.0
MIN	0.0	0.0	0.0	0.0	293.0	108.0	407.0	6.1	66.7	5.7	0.0	0.0
TOTAL AF	1,237.0	2,091.0	9,186.0	17,490.0	31,120.0	69,320.0	27,480.0	17,190.0	8,167.0	14,490.0	3,280.0	0.0

## WATER YEAR 1995-1996 (DISCHARGE IN CFS)

MONTH	OCT	NOV	DEC	JAN	FEB	MAR	APR	MAY	JUN	JUL	AUG	SEP
MEAN	143.0	0.0	0.0	1.8	45.0	26.0	80.6	125.0	194.0	85.4	176.0	225.0
MAX	460.0	0.0	0.0	57.2	531.0	195.0	187.0	224.0	318.0	137.0	297.0	426.0
MIN	0.0	0.0	0.0	0.0	0.0	6.2	14.7	5.4	2.3	0.0	7.4	6.7
TOTAL AF	8,784.0	0.0	0.0	113.0	2,586.0	1,596.0	4,798.0	7,688.0	11,520.0	5,249.0	10,840.0	13,390.0

Note : All figures are in terms of daily amounts, i.e., Mean Daily, Maximum Daily & Minimum Daily.



# RIO HONDO

## below Lower Azusa Road

### STATION NO. F192B-R

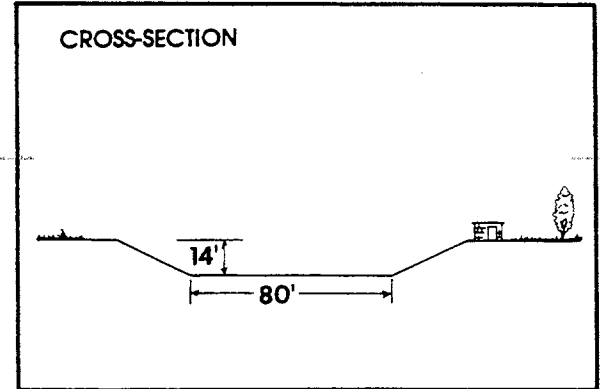
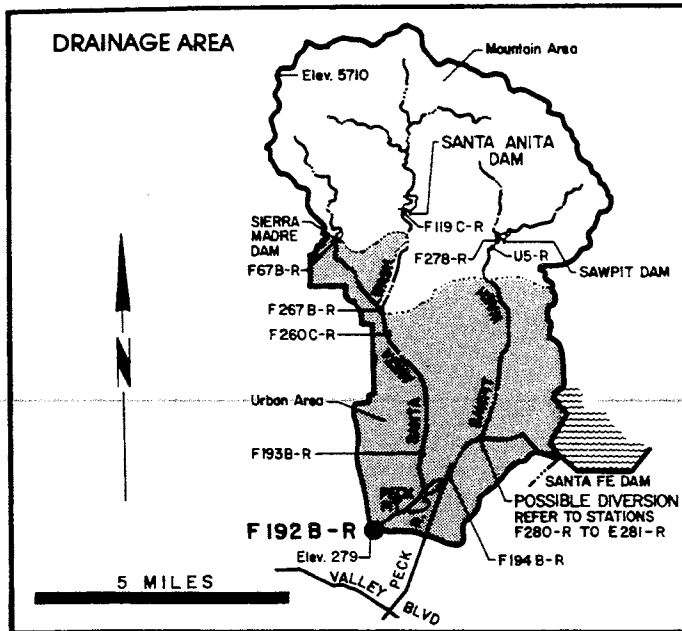
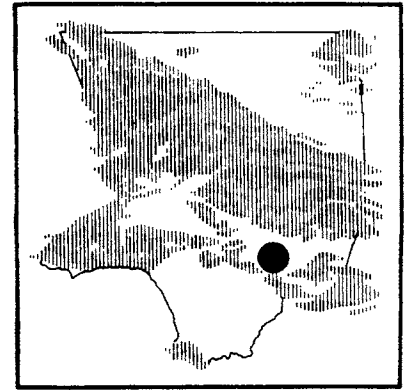

RECORDER- continuous water stage.

METHOD OF MEASUREMENTS- wading.

DRAINAGE AREA- 40.9 square miles (excludes area above Santa Fe Dam).

LOCATION- 300.0 feet downstream from Lower Azusa Road, 1.5 miles north of El Monte.

REGULATION- partially regulated by Sierra Madre Dam, Santa Anita Dam, Sawpit Dam, Santa Fe Dam, Peck Pft, Buena Vista Pft, and several debris basins.

CHANNEL- concrete, trapezoidal in section.

CONTROL- channel forms control.

LENGTH OF RECORD- at Station F192-R February 22, 1932 to May 7, 1958. at Station F192B-R May 7, 1958 to date.

REMARKS- subject to diversions from Monrovia, Sawpit, and Little Santa Anita Creeks. Also from the San Gabriel River below Santa Fe Dam; and for irrigation and spreading.

### WATER YEAR 1994-1995 (DISCHARGE IN CFS)

MONTH	OCT	NOV	DEC	JAN	FEB	MAR	APR	MAY	JUN	JUL	AUG	SEP
MEAN	0.2	3.3	51.3	100.0	67.3	119.0	13.0	35.6	15.5	0.0	0.0	0.0
MAX	3.9	27.4	324.0	803.0	157.0	716.0	113.0	75.1	99.9	0.0	0.2	0.1
MIN	0.0	0.0	0.1	0.1	0.0	0.9	0.0	0.0	0.0	0.0	0.0	0.0
TOTAL AF	14.0	197.0	3,154.0	6,168.0	3,739.0	7,337.0	773.0	2,191.0	921.0	0.0	1.0	0.0

### WATER YEAR 1995-1996 (DISCHARGE IN CFS)

MONTH	OCT	NOV	DEC	JAN	FEB	MAR	APR	MAY	JUN	JUL	AUG	SEP
MEAN	86.4	0.0	0.3	2.0	45.6	8.8	0.3	0.1	117.0	0.9	11.6	79.0
MAX	238.0	0.3	4.4	45.9	665.0	196.0	1.9	0.5	232.0	18.1	49.4	170.0
MIN	0.0	0.0	0.0	0.0	0.2	0.0	0.0	0.0	0.0	0.0	0.0	12.6
TOTAL AF	5,312.0	1.0	20.0	175.0	2,621.0	540.0	18.0	3.0	6,991.0	54.0	716.0	4,704.0

Note : All figures are in terms of daily amounts, i.e., Mean Daily, Maximum Daily & Minimum Daily.

# SANTA ANITA WASH

## at Longden Avenue

### STATION NO. F193B-R

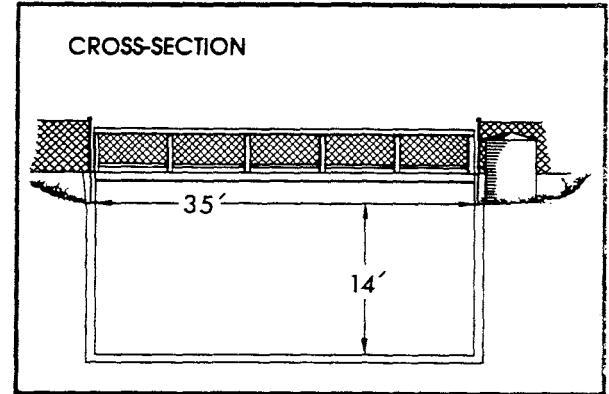
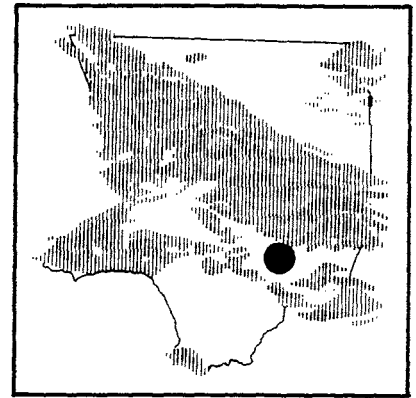
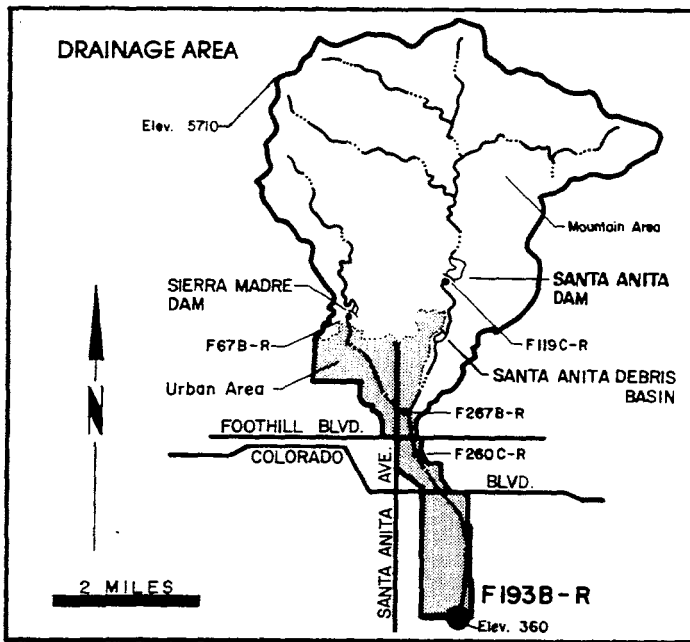

RECORDER - continuous water stage.

METHOD OF MEASUREMENTS- wading or from bridge.

DRAINAGE AREA- 18.8 square miles.

LOCATION - 30.0 feet above Longden Avenue, 1.5 miles south of Arcadia.

REGULATION - regulated by Santa Anita and Sierra Madre Dams, and Santa Anita Debris Basin.

CHANNEL - concrete rectangular section.

CONTROL- channel forms control.

LENGTH OF RECORD- at Station F193-R, April 25, 1932 to March 1, 1938. at Station F193B-R, January 5, 1960 to date.

#### WATER YEAR 1994-1995 (DISCHARGE IN CFS)

MONTH	OCT	NOV	DEC	JAN	FEB	MAR	APR	MAY	JUN	JUL	AUG	SEP
MEAN	1.2	1.3	1.3	45.3	30.1	98.6	36.4	12.7	3.0	0.3	0.3	0.1
MAX.	20.7	26.6	13.1	375.0	239.0	256.0	71.7	30.5	24.4	0.6	0.6	0.6
MIN	0.0	0.0	0.1	0.0	0.2	19.1	0.1	0.2	0.1	0.1	0.0	0.0
TOTAL AF	73.0	75.0	80.0	2,785.0	1,672.0	6,063.0	2,166.0	784.0	180.0	19.0	16.0	8.0

#### WATER YEAR 1995-1996 (DISCHARGE IN CFS)

MONTH	OCT	NOV	DEC	JAN	FEB	MAR	APR	MAY	JUN	JUL	AUG	SEP
MEAN	0.1	0.2	1.4	3.6	26.9	18.2	2.1	1.0	0.6	0.4	0.1	0.4
MAX.	0.7	2.5	16.3	75.3	299.0	76.5	11.3	4.2	1.3	3.7	0.9	0.8
MIN	0.0	0.0	0.1	0.1	0.0	0.6	0.0	0.0	0.2	0.1	0.0	0.0
TOTAL AF	6.0	14.0	84.0	220.0	1,545.0	1,117.0	122.0	64.0	35.0	22.0	5.0	22.0

Note: All figures are in terms of daily amounts, i.e., Mean Daily, Maximum Daily & Minimum Daily.

# SAWPIT WASH

## below Live Oak Avenue

### STATION NO. F194B-R

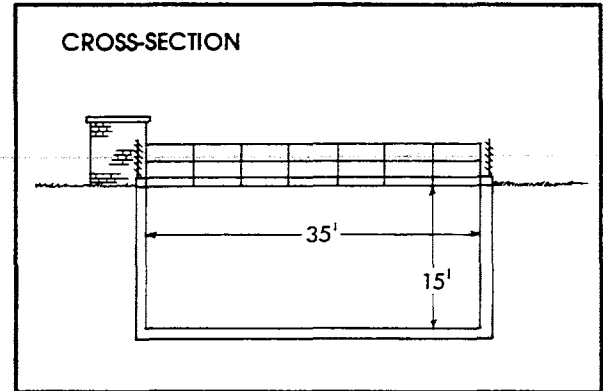
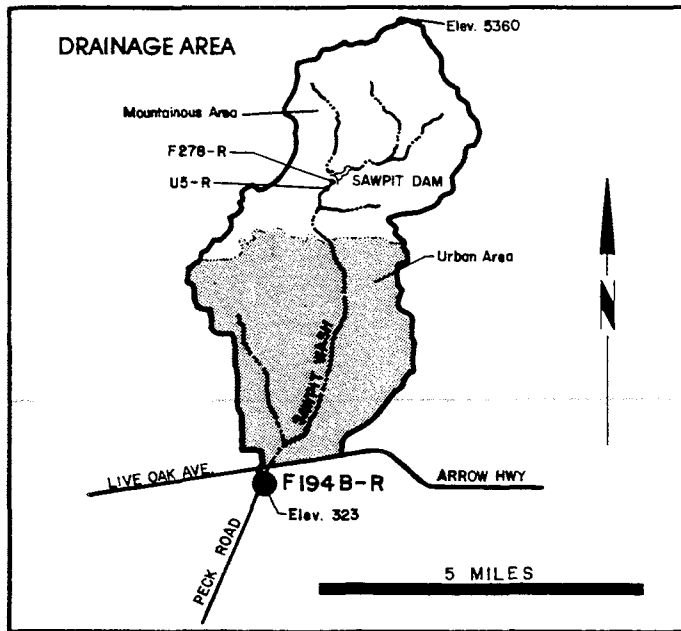
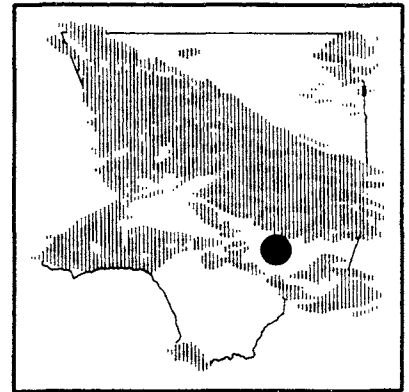

RECORDER- continuous water stage.

METHOD OF MEASUREMENTS- wading or from footbridge.

DRAINAGE AREA- 16.1 square miles.

LOCATION- 1,500 feet below Arrow Highway, 3.0 miles south of Monrovia.

REGULATION- partially regulated by Sawpit and Santa Fe Dams, and by several debris basins.

CHANNEL- concrete, rectangular section.

CONTROL- channel forms control.

LENGTH OF RECORD- at Station F194-R February 22, 1932 to September 1, 1935. at Station F194B-R December 5, 1960 to date.

### WATER YEAR 1994-1995 (DISCHARGE IN CFS)

MONTH	OCT	NOV	DEC	JAN	FEB	MAR	APR	MAY	JUN	JUL	AUG	SEP
MEAN	1.5	12.0	54.9	92.9	71.1	39.1	10.1	44.9	22.6	1.2	1.1	1.0
MAX.	33.3	135.0	306.0	495.0	184.0	208.0	76.6	93.3	90.2	3.7	1.4	1.2
MIN	0.1	0.1	0.2	0.8	5.9	5.7	1.1	0.8	1.1	0.1	0.8	0.8
TOTAL AF	93.0	714.0	3,376.0	5,711.0	3,950.0	2,405.0	598.0	2,760.0	1,346.0	76.0	69.0	61.0

### WATER YEAR 1995-1996 (DISCHARGE IN CFS)

MONTH	OCT	NOV	DEC	JAN	FEB	MAR	APR	MAY	JUN	JUL	AUG	SEP
MEAN	135.0	1.7	3.3	9.8	33.9	48.6	2.9	4.2	164.0	0.5	36.3	91.3
MAX.	382.0	3.6	35.0	225.0	451.0	530.0	13.8	73.2	335.0	2.9	157.0	142.0
MIN	1.1	1.6	0.8	0.4	0.4	1.0	1.6	0.5	0.6	0.2	0.2	0.3
TOTAL AF	8,314.0	103.0	200.0	602.0	1,952.0	2,988.0	171.0	259.0	9,740.0	31.0	2,230.0	5,430.0

Note : All figures are in terms of daily amounts, i.e., Mean Daily, Maximum Daily & Minimum Daily.

# SAN GABRIEL-AZUSA CONDUIT

## at 25 ft. Weir below San Gabriel Dam

### STATION NO. F250-R

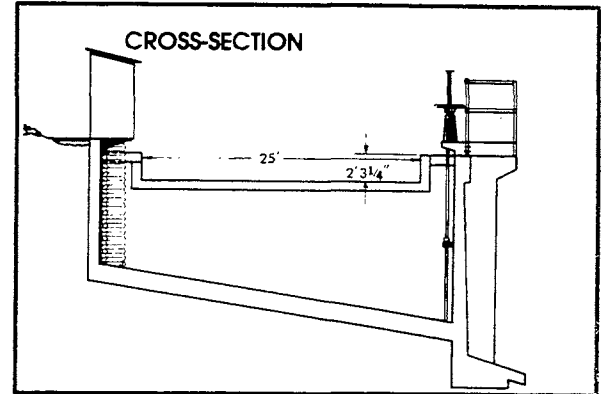
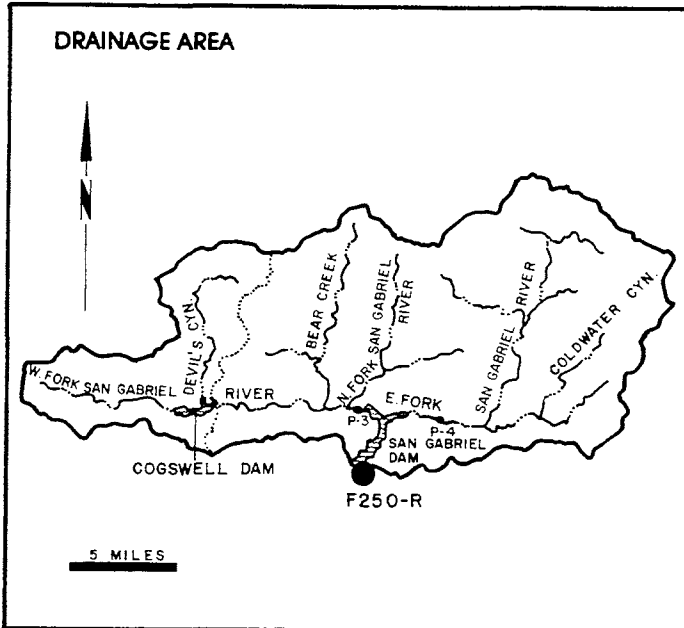
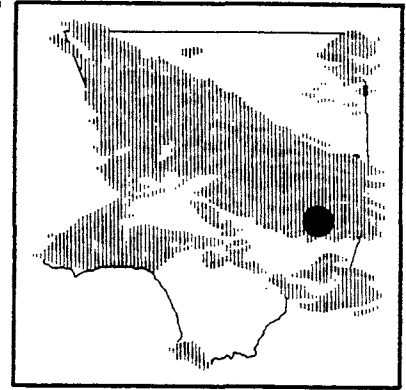

RECORDER- continuous water stage.  
 METHOD OF MEASUREMENTS- weir formula with gage height observation.  
 DRAINAGE AREA- none.  
 LOCATION- on the concrete conduit which diverts from San Gabriel Dam, 160 feet below the Dam.  
 REGULATION- regulated in section.  
 CONTROL- 25-foot concrete weir.  
 LENGTH OF RECORD- February 26, 1933, to date.  
 REMARKS- approximate capacity 95 second-feet.

#### WATER YEAR 1994-1995 (DISCHARGE IN CFS)

MONTH	OCT	NOV	DEC	JAN	FEB	MAR	APR	MAY	JUN	JUL	AUG	SEP
MEAN	36.1	32.7	28.8	57.9	71.7	69.8	48.0	71.4	72.8	76.7	80.3	73.2
MAX	36.4	36.2	33.1	83.9	77.8	79.4	54.4	72.2	74.3	81.4	81.8	76.7
MIN	35.8	32.0	0.0	0.0	42.8	35.9	20.4	70.3	71.3	73.5	77.0	70.6
TOTAL AF	2,218.0	1,944.0	1,770.0	3,563.0	3,982.0	4,292.0	2,856.0	4,390.0	4,330.0	4,714.0	4,936.0	4,357.0

#### WATER YEAR 1995-1996 (DISCHARGE IN CFS)

MONTH	OCT	NOV	DEC	JAN	FEB	MAR	APR	MAY	JUN	JUL	AUG	SEP
MEAN	70.0	59.6	43.3	43.7	35.5	25.6	43.5	70.7	69.9	67.1	67.2	67.8
MAX	76.6	68.0	44.4	44.9	44.0	73.8	71.2	72.7	72.0	73.7	70.8	69.3
MIN	64.8	43.2	42.3	42.4	1.1	0.9	0.0	49.8	68.4	0.5	44.5	66.6
TOTAL AF	4,303.0	3,545.0	2,660.0	2,686.0	2,040.0	1,573.0	2,588.0	4,350.0	4,158.0	4,125.0	4,131.0	4,034.0

Note : All figures are in terms of daily amounts, i.e., Mean Daily, Maximum Daily & Minimum Daily.

# VERDUGO WASH at Estelle Avenue STATION NO. F252-R

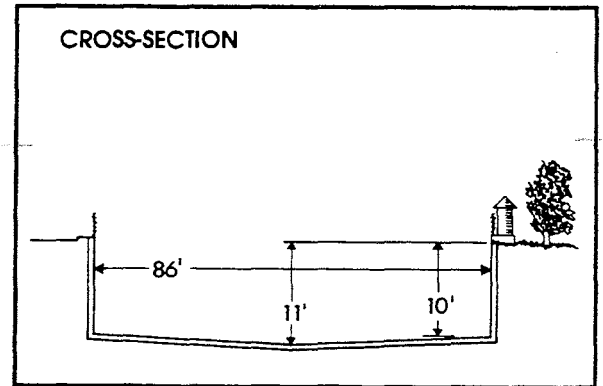
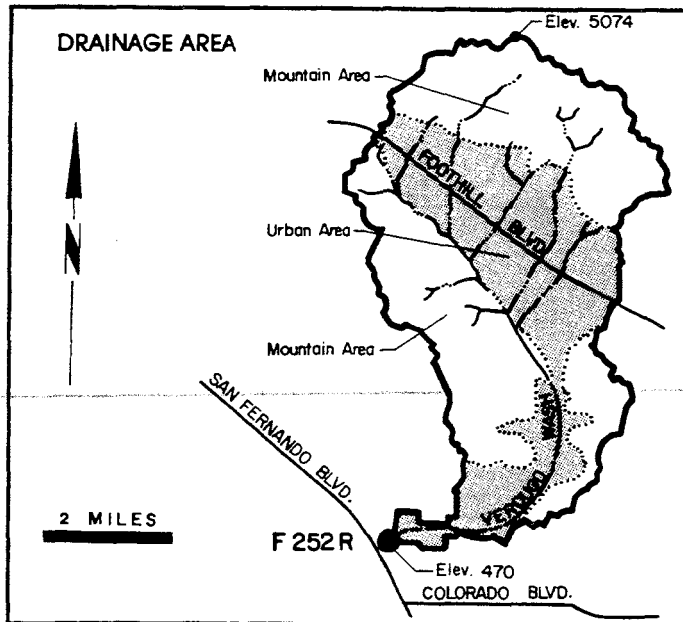
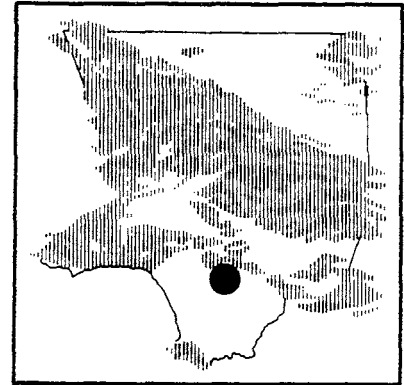

RECORDER- continuous water stage.  
 METHOD OF MEASUREMENTS- wading or from Concord Street Bridge.  
 DRAINAGE AREA- 26.8 square miles.  
 LOCATION- 800.0 feet east of San Fernando Road, 2.0 miles northwest of Glendale.  
 REGULATION- partially regulated by several debris basins.  
 CHANNEL- concrete, rectangular in section.  
 CONTROL- channel forms control.  
 LENGTH OF RECORD- December 2, 1935 to date.

## WATER YEAR 1994-1995 (DISCHARGE IN CFS)

MONTH	OCT	NOV	DEC	JAN	FEB	MAR	APR	MAY	JUN	JUL	AUG	SEP
MEAN	2.3	2.4	26.8	304.0	42.7	140.0	7.9	2.9	18.6	2.2	1.9	1.8
MAX	2.3	3.9	398.0	1,710.0	1,060.0	1,030.0	58.5	11.9	371.0	2.5	2.0	2.3
MIN	2.3	1.9	2.0	2.3	1.4	1.7	1.6	1.9	2.3	2.0	1.7	1.0
TOTAL AF	141.0	140.0	1,648.0	18,690.0	2,373.0	8,589.0	470.0	178.0	1,107.0	138.0	114.0	108.0

## WATER YEAR 1995-1996 (DISCHARGE IN CFS)

MONTH	OCT	NOV	DEC	JAN	FEB	MAR	APR	MAY	JUN	JUL	AUG	SEP
MEAN	2.5	2.5	8.2	21.4	99.9	78.6	3.7	3.0	1.7	2.3	1.5	1.4
MAX	6.6	4.8	117.0	448.0	1,260.0	848.0	27.8	5.3	2.3	5.1	1.7	1.5
MIN	0.8	2.3	1.1	2.3	2.5	2.8	2.3	2.3	1.0	1.2	1.2	1.2
TOTAL AF	152.0	149.0	505.0	1,315.0	5,746.0	4,832.0	220.0	185.0	103.0	143.0	89.0	83.0

Note : All figures are in terms of daily amounts, i.e., Mean Daily, Maximum Daily & Minimum Daily.

# SAN GABRIEL RIVER

## below Valley Boulevard

### STATION NO. F261C-R

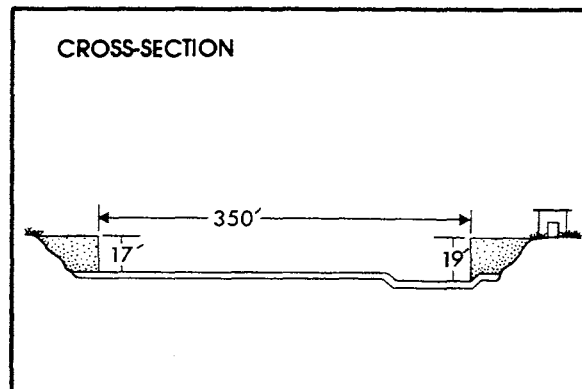
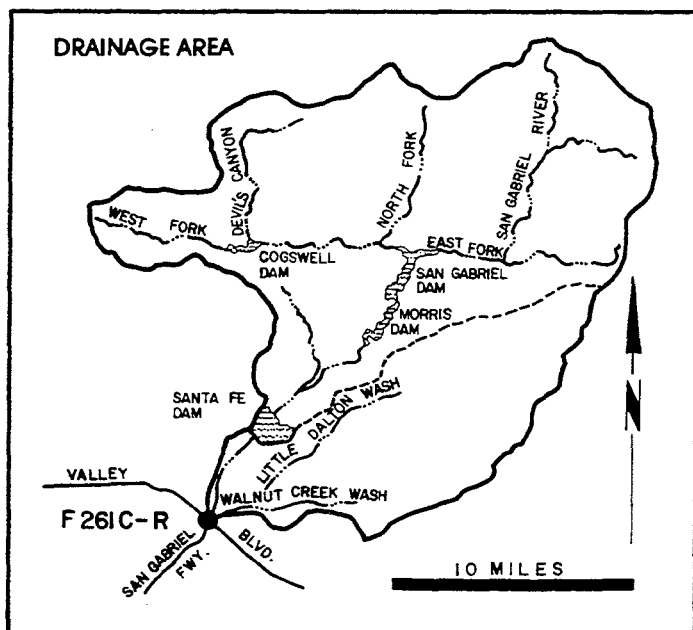

RECORDER- continuous water stage.

METHOD OF MEASUREMENTS- wading.

DRAINAGE AREA- 118.0 square miles (excludes area above Santa Fe Dam).

LOCATION- 1,150.0 feet below Valley Boulevard, 2.5 miles east of El Monte.

REGULATION- partly regulated by Santa Fe, Big Dalton, Puddingstone Diversion, and Puddingstone Dams.

CHANNEL- sand and gravel bottom with rip-rap side slopes; trapezoidal section.

CONTROL- concrete stabilizer with low-flow notch.

LENGTH OF RECORD- at Station F261-R March 11, 1937 to September 30, 1941. at Station F261B-R October 1, 1941 to April 23, 1946. at Station F261C-R November 29, 1960 to date.

REMARKS- flows may include imported water originating at Metropolitan Water District outlets at San Dimas Canyon and below San Bernardino Road.

### WATER YEAR 1994-1995 (DISCHARGE IN CFS)

MONTH	OCT	NOV	DEC	JAN	FEB	MAR	APR	MAY	JUN	JUL	AUG	SEP
MEAN	*	*	*	*	*	*	*	*	*	*	*	*
MAX.	*	*	*	*	*	*	*	*	*	*	*	*
MIN	*	*	*	*	*	*	*	*	*	*	*	*
TOTAL AF	*	*	*	*	*	*	*	*	*	*	*	*

### WATER YEAR 1995-1996 (DISCHARGE IN CFS)

MONTH	OCT	NOV	DEC	JAN	FEB	MAR	APR	MAY	JUN	JUL	AUG	SEP
MEAN												
MAX.												
MIN												
TOTAL AF												

LEGEND \* - Recorder was out of service - rubber dam inflated.

Note : All figures are in terms of daily amounts, i.e., Mean Daily, Maximum Daily & Minimum Daily.

# SAN GABRIEL RIVER above Florence Avenue STATION NO. F262C-R

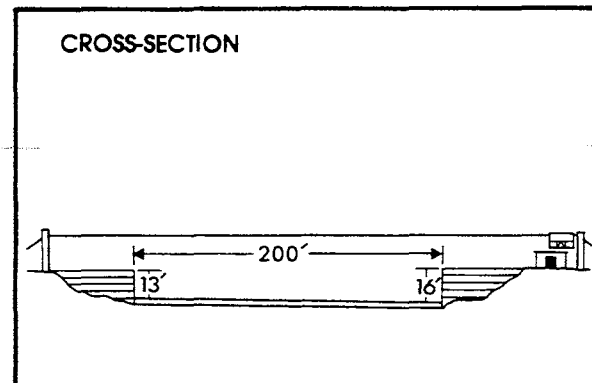
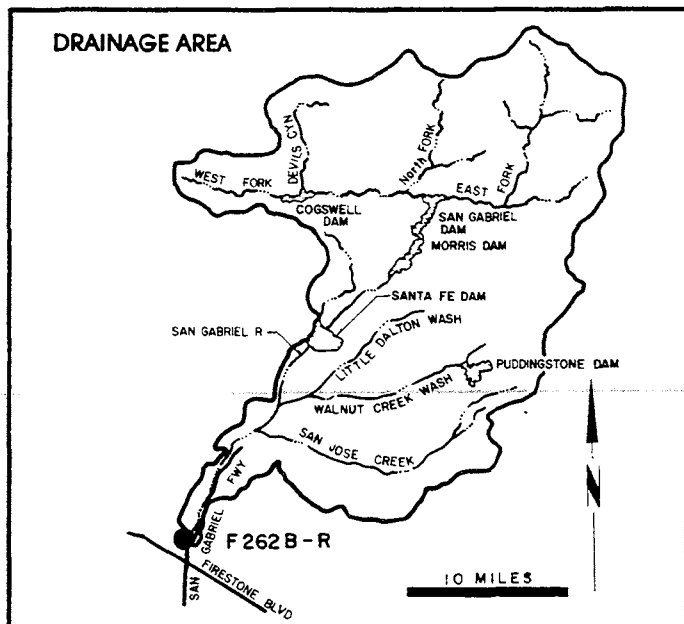
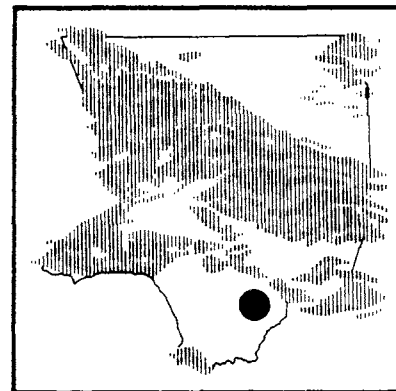

RECORDER- continuous water stage.

METHOD OF MEASUREMENTS- wading or from cable car.

DRAINAGE AREA- 215.8 square miles (excludes area above Santa Fe Dam).

LOCATION- 1,400 feet above Florence Avenue, 2.0 miles east of Downey.

REGULATION- partially regulated by Cogswell, San Gabriel, Morris, Santa Fe, Big Dalton, San Dimas, Puddingstone Diversion, Puddingstone, Live Oak, Thompson Creek and Whittier Narrows Dams, several debris basins, MWD outlets, and several spreading grounds.

CHANNEL- sand bottom with rip-rap slopes, trapezoidal section.

CONTROL- concrete stabilizer.

LENGTH OF RECORD- at Station F267-R February 27, 1937 to September 30, 1967. at Station F262B-R August 6, 1968 to date.

REMARKS- no record during 1967-1968 season due to channel construction.

## WATER YEAR 1994-1995 (DISCHARGE IN CFS)

MONTH	OCT	NOV	DEC	JAN	FEB	MAR	APR	MAY	JUN	JUL	AUG	SEP
MEAN	0.0	0.0	0.0	64.9	22.3	304.0	0.0	0.0	0.0	0.7	4.7	25.1
MAX.	0.0	0.0	0.0	897.0	594.0	1,520.0	0.0	0.1	0.0	6.7	86.9	105.0
MIN	0.0	0.0	0.0	0.0	0.0	0.0	0.0	0.0	0.0	0.0	0.0	0.0
TOTAL AF	0.0	0.0	0.0	3,991.0	1,237.0	18,700.0	0.0	0.0	0.0	42.0	290.0	1,493.0

## WATER YEAR 1995-1996 (DISCHARGE IN CFS)

MONTH	OCT	NOV	DEC	JAN	FEB	MAR	APR	MAY	JUN	JUL	AUG	SEP
MEAN	0.0	0.0	0.0	2.2	39.2	5.0	*0.62	0.0	0.0	0.0	0.0	0.0
MAX.	0.0	0.0	0.2	67.8	871.0	91.7	*15.2	0.0	0.0	0.0	0.0	0.0
MIN	0.0	0.0	0.0	0.0	0.0	0.0	*0	0.0	0.0	0.0	0.0	0.0
TOTAL AF	0.0	0.0	0.0	138.0	2,254.0	306.0	*29.5	0.0	0.0	0.0	0.0	0.0

LEGEND \* - Data was estimated.

Note : All figures are in terms of daily amounts, i.e., Mean Daily, Maximum Daily & Minimum Daily.

# SAN GABRIEL RIVER

## below San Gabriel River Parkway

### STATION NO. F263C-R

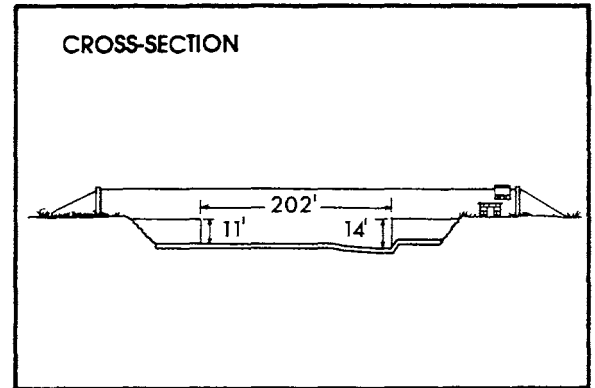
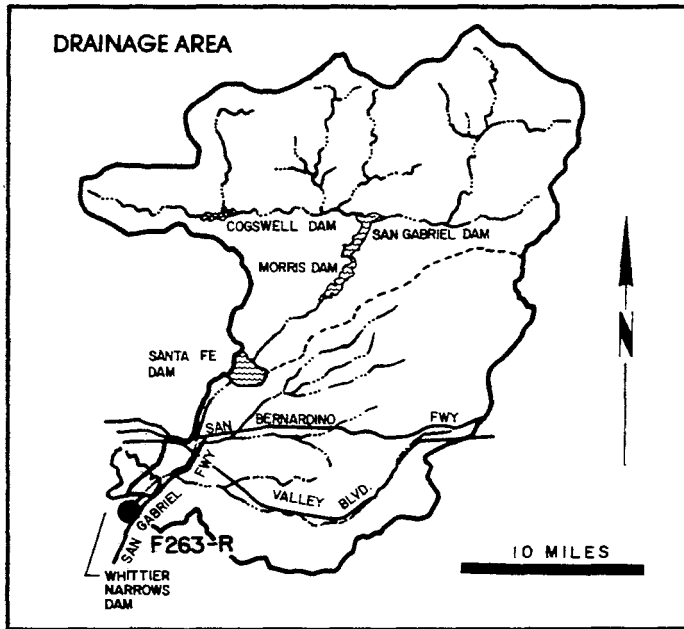
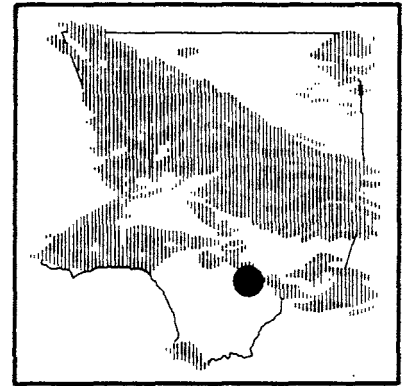

RECORDER- continuous water stage.

METHOD OF MEASUREMENTS- wading or from cable car.

DRAINAGE AREA- 206.3 square miles (excludes area above Santa Fe Dam).

LOCATION- 462.0 feet below San Gabriel River Parkway, 1.4 miles northeast of Pico Rivera.

REGULATION- partly regulated by Santa Fe, Big Dalton, Puddingstone Diversion, Puddingstone, and Thompson Creek Dams. Flows may include imported water from several Metropolitan Water District outlets. Water is at times diverted to the Zone I ditch upstream of Whittier Narrows Dam.

CHANNEL- rip-rap slopes with sand bottom trapezoidal section.

CONTROL- concrete stabilizer.

LENGTH OF RECORD - at Station F263-R February 4, 1937 to March 6, 1952. at Station F263B-R March 6, 1952 to August 9, 1968. at Station F263C-R August 9, 1968 to date.

### WATER YEAR 1994-1995 (DISCHARGE IN CFS)

MONTH	OCT	NOV	DEC	JAN	FEB	MAR	APR	MAY	JUN	JUL	AUG	SEP
MEAN	102.0	57.8	92.2	239.0	147.0	680.0	78.9	82.8	47.3	107.0	70.1	39.4
MAX	308.0	367.0	264.0	1,030.0	1,180.0	2,470.0	398.0	207.0	307.0	127.0	99.0	83.4
MIN	0.0	1.9	1.9	29.4	7.1	26.1	51.3	13.1	9.7	86.3	42.6	3.7
TOTAL AF	6,268.0	3,437.0	5,669.0	14,720.0	8,183.0	41,810.0	4,695.0	5,093.0	2,817.0	6,569.0	4,309.0	2,343.0

### WATER YEAR 1995-1996 (DISCHARGE IN CFS)

MONTH	OCT	NOV	DEC	JAN	FEB	MAR	APR	MAY	JUN	JUL	AUG	SEP
MEAN	4.7	14.2	35.7	50.8	118.0	74.7	72.8	70.8	52.7	54.8	2.9	25.5
MAX	6.6	44.4	516.0	542.0	794.0	397.0	201.0	110.0	83.3	123.0	5.3	76.2
MIN	3.7	4.1	4.7	3.6	4.4	12.6	22.8	20.3	11.1	11.0	1.9	1.6
TOTAL AF	290.0	847.0	2,193.0	3,123.0	6,785.0	4,592.0	4,334.0	4,355.0	3,135.0	3,370.0	180.0	1,516.0

Note : All figures are in terms of daily amounts, i.e., Mean Daily, Maximum Daily & Minimum Daily.



# DALTON WASH at Merced Avenue STATION NO. F274B-R

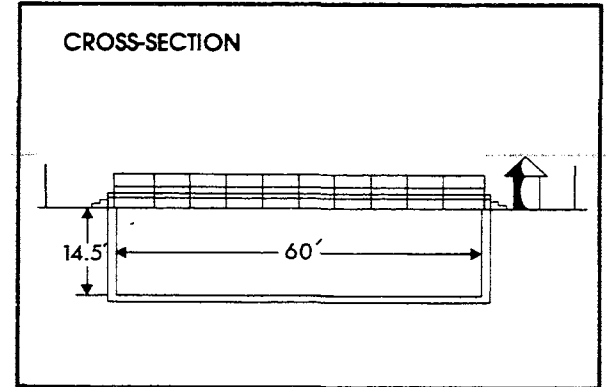
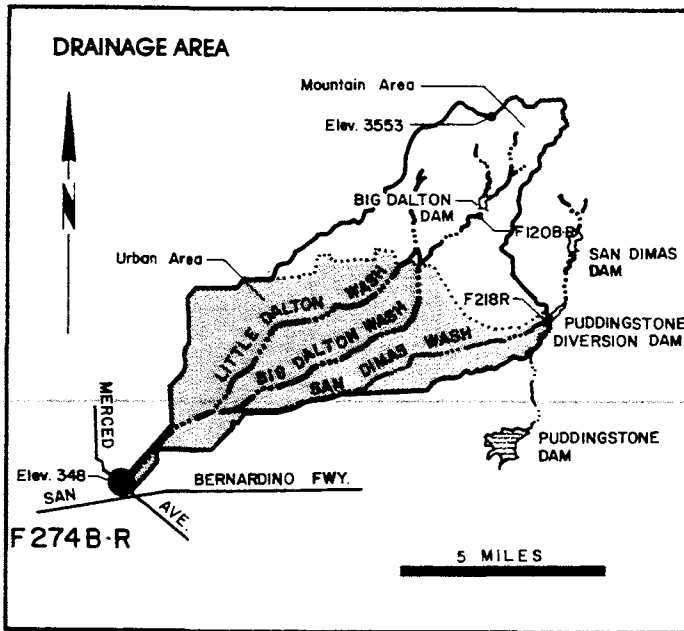
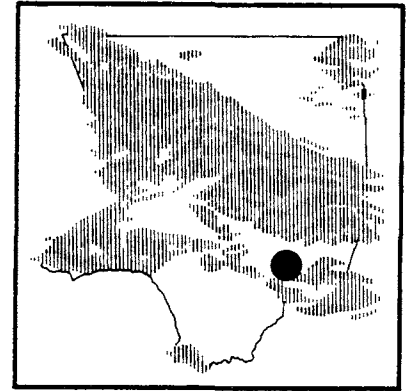

RECORDER- 15 minute punched tape.

METHOD OF MEASUREMENTS- low flows measured by wading. High flows measured from footbridge 100 feet upstream from station.

DRAINAGE AREA- 36.0 square miles, not including the area above Puddingstone Diversion Dam.

LOCATION- on the west bank and upstream of Merced Avenue about 150 feet, about one-half mile above the junction with Walnut Wash and about one mile south of Baldwin Park.

REGULATION- partly regulated by Big Dalton Dam, San Dimas Dam, Puddingstone Diversion Dam, Big Dalton Spreading Grounds, Little Dalton Spreading Grounds, Big Dalton Debris Basin, Little Dalton Debris Basin, and Irwindale Spreading Grounds.

REMARKS- flow may include imported water originating at San Dimas.

## WATER YEAR 1994-1995 (DISCHARGE IN CFS)

MONTH	OCT	NOV	DEC	JAN	FEB	MAR	APR	MAY	JUN	JUL	AUG	SEP
MEAN	3.9	3.8	4.7	84.8	9.7	94.3	7.6	1.0	7.0	12.0	0.9	2.1
MAX.	58.8	90.5	53.9	1,070.0	205.0	770.0	117.0	2.3	24.7	29.2	3.6	8.9
MIN.	0.1	0.3	0.2	0.9	0.3	0.2	0.1	0.2	0.1	0.4	0.2	0.2
TOTAL AF	239.0	226.0	292.0	5,215.0	539.0	5,800.0	453.0	62.0	415.0	739.0	57.0	123.0

## WATER YEAR 1995-1996 (DISCHARGE IN CFS)

MONTH	OCT	NOV	DEC	JAN	FEB	MAR	APR	MAY	JUN	JUL	AUG	SEP
MEAN	4.1	2.3	5.1	23.6	69.2	17.7	4.3	3.4	10.1	11.3	9.5	5.9
MAX.	11.6	4.2	51.8	501.0	925.0	172.0	25.2	4.6	25.9	28.6	17.8	10.5
MIN.	0.8	1.3	0.7	1.2	0.9	2.2	0.4	0.6	0.2	0.2	3.6	2.2
TOTAL AF	253.0	138.0	315.0	1,450.0	3,978.0	1,090.0	254.0	211.0	603.0	692.0	582.0	353.0

Note : All figures are in terms of daily amounts, i.e., Mean Daily, Maximum Daily & Minimum Daily.

# SANTA FE CHANNEL

## below Santa Fe Dam

### STATION NO. F280-R

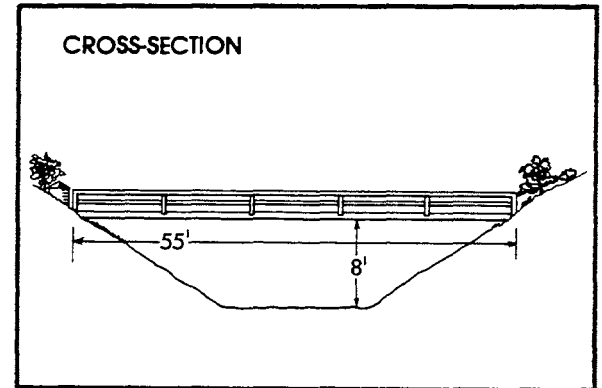
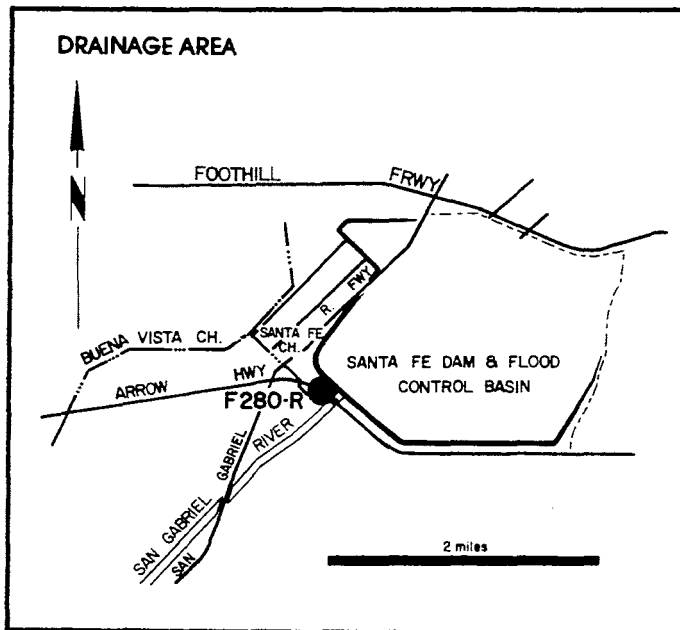
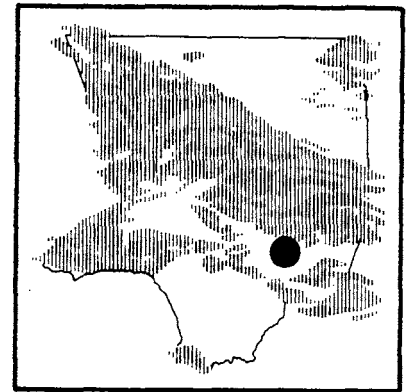

RECORDER- continuous water stage.

METHOD OF MEASUREMENTS- wading or from footbridge.

DRAINAGE AREA- controlled.

LOCATION- 400.0 feet downstream of Santa Fe Dam outlet and 1.5 miles north of Baldwin Park.

REGULATION- flow regulated by five gates of stilling basin outlet of Santa Fe Dam.

CHANNEL- sand and gravel, natural section.

CONTROL- concrete stabilizer.

LENGTH OF RECORD- at Station F280-S October 1, 1942 to May 12, 1944. at Station F280-R May 12, 1944 to date.

#### WATER YEAR 1994-1995 (DISCHARGE IN CFS)

MONTH	OCT	NOV	DEC	JAN	FEB	MAR	APR	MAY	JUN	JUL	AUG	SEP
MEAN	0.3	15.9	71.5	43.1	56.6	6.8	6.4	66.3	17.2	0.0	0.0	0.0
MAX	1.7	212.0	410.0	154.0	153.0	74.9	72.0	138.0	49.0	0.0	0.0	0.0
MIN	0.0	0.0	0.0	0.0	0.0	0.0	0.5	0.0	0.0	0.0	0.0	0.0
TOTAL AF	16.0	946.0	4,394.0	2,650.0	3,144.0	421.0	383.0	4,074.0	1,021.0	0.0	0.0	0.0

#### WATER YEAR 1995-1996 (DISCHARGE IN CFS)

MONTH	OCT	NOV	DEC	JAN	FEB	MAR	APR	MAY	JUN	JUL	AUG	SEP
MEAN	134.0	0.0	0.0	0.0	0.1	0.0	0.0	3.0	162.0	0.6	37.5	93.3
MAX	385.0	0.0	0.0	0.5	0.6	0.0	0.0	60.5	333.0	2.6	161.0	146.0
MIN	0.0	0.0	0.0	0.0	0.0	0.0	0.0	0.0	0.0	0.0	0.0	0.0
TOTAL AF	8,269.0	0.0	0.0	3.0	3.0	0.0	0.0	185.0	9,636.0	34.3	2,304.0	5,554.0

Note : All figures are in terms of daily amounts, i.e., Mean Daily, Maximum Daily & Minimum Daily.

# BURBANK-WESTERN ST. DR.

## at Riverside Drive

### STATION NO. E 285-R

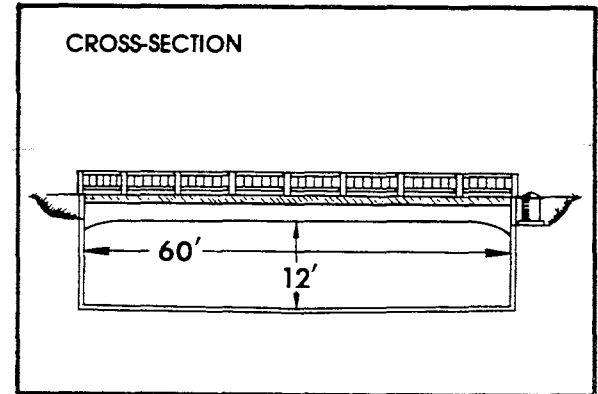
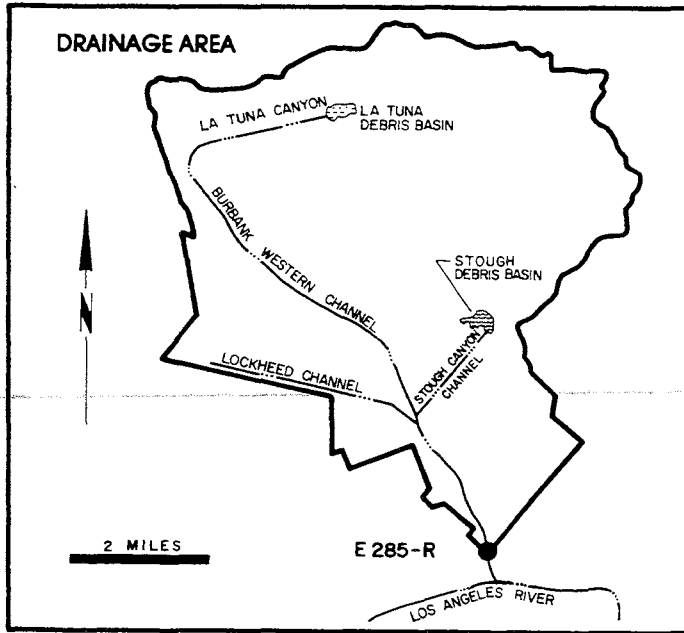
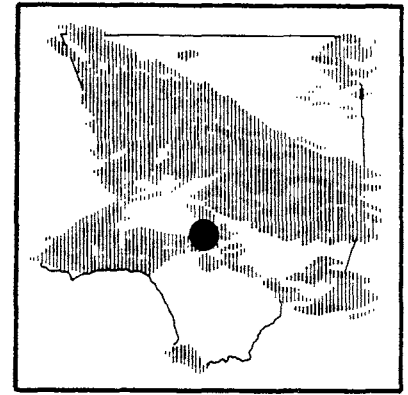

RECORDER- continuous water stage.  
 METHOD OF MEASUREMENTS- wading and from bridge.  
 DRAINAGE AREA- 25.0 square miles.  
 LOCATION- 20.0 feet upstream from Riverside Drive bridge, Glendale.  
 REGULATION- Several debris basins on tributaries.  
 CHANNEL- concrete, rectangular section.  
 CONTROL- channel forms control.  
 LENGTH OF RECORD- October 1, 1949 to date.  
 REMARKS- operated in cooperation with the USCE.

#### WATER YEAR 1994-1995 (DISCHARGE IN CFS)

MONTH	OCT	NOV	DEC	JAN	FEB	MAR	APR	MAY	JUN	JUL	AUG	SEP
MEAN	35.9	24.3	54.3	109.0	27.9	123.0	16.0	16.1	23.1	13.6	15.0	14.0
MAX.	452.0	328.0	299.0	743.0	118.0	705.0	146.0	18.5	169.0	14.1	16.8	15.4
MIN	6.0	2.4	2.8	10.5	11.2	12.8	6.0	14.0	11.0	12.8	12.8	10.2
TOTAL AF	2,209.0	1,444.0	3,336.0	6,692.0	1,551.0	7,544.0	954.0	989.0	1,374.0	839.0	920.0	835.0

#### WATER YEAR 1995-1996 (DISCHARGE IN CFS)

MONTH	OCT	NOV	DEC	JAN	FEB	MAR	APR	MAY	JUN	JUL	AUG	SEP
MEAN	12.8	12.8	13.0	16.3	135.0	20.3	10.6	10.2	9.3	10.1	9.4	10.1
MAX.	13.9	12.8	21.2	95.6	1,330.0	80.3	32.2	12.4	11.4	13.4	11.5	12.1
MIN	7.8	12.8	10.9	10.2	9.6	8.9	5.3	8.7	7.1	7.6	7.2	7.2
TOTAL AF	785.0	762.0	802.0	1,004.0	7,740.0	1,247.0	629.0	624.0	552.0	620.0	581.0	603.0

Note : All figures are in terms of daily amounts, i.e., Mean Daily, Maximum Daily & Minimum Daily.

# LOS ANGELES RIVER at Tujunga Avenue STATION NO. F300-R

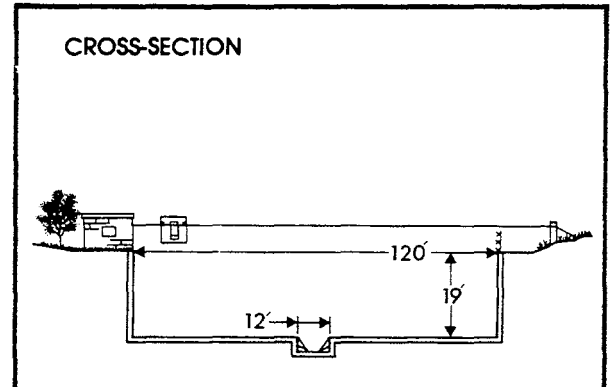
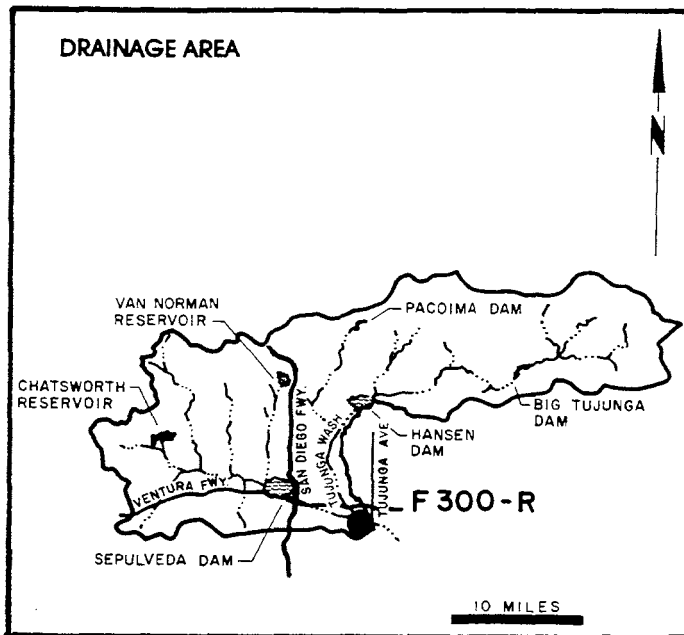
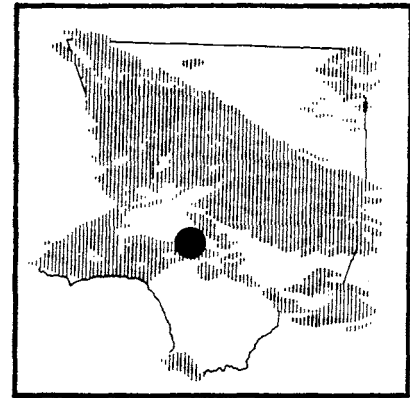

**RECORDER-** continuous water stage.  
**METHOD OF MEASUREMENTS-** wading or from cable car.  
**DRAINAGE AREA-** 401.0 square miles.  
**LOCATION-** 200.0 feet above Tujunga Avenue bridge, Studio City.  
**REGULATION-** flow regulated by Sepulveda, Big Tujunga, Hansen, and Pacoima Dams, Lopez Debris Dam, and Project No. 85 Diversion.  
**CHANNEL-** concrete, rectangular section, 120 feet wide by 19 feet deep.  
**CONTROL-** channel forms control.  
**LENGTH OF RECORD-** May 8, 1950, to date.  
**REMARKS-** subject to diversions at mouth of Big Tujunga and Pacoima Canyons for irrigation, at Big Tujunga, Branford, Hansen, and Pacoima Spreading Grounds.

## WATER YEAR 1994-1995 (DISCHARGE IN CFS)

MONTH	OCT	NOV	DEC	JAN	FEB	MAR	APR	MAY	JUN	JUL	AUG	SEP
MEAN	112.0	94.2	127.0	*	*	619.0	123.0	84.3	85.3	70.2	84.5	67.2
MAX.	635.0	526.0	1,050.0	*	*	6,470.0	645.0	164.0	227.0	75.8	96.1	85.4
MIN	63.0	65.6	63.5	*	*	87.1	81.1	65.9	65.2	66.0	57.9	53.7
TOTAL AF	6,884.0	5,603.0	7,812.0	*	*	38,040.0	7,308.0	5,185.0	5,074.0	4,317.0	5,197.0	4,001.0

## WATER YEAR 1995-1996 (DISCHARGE IN CFS)

MONTH	OCT	NOV	DEC	JAN	FEB	MAR	APR	MAY	JUN	JUL	AUG	SEP
MEAN	75.3	83.7	142.0	150.0	321.0	143.0	103.0	79.4	77.3	79.6	75.5	78.8
MAX.	89.9	107.0	1,040.0	1,380.0	3,110.0	831.0	346.0	101.0	82.3	93.5	87.8	86.8
MIN	55.5	68.5	81.0	75.3	77.1	74.9	68.8	51.0	62.7	69.6	54.7	65.4
TOTAL AF	4,628.0	4,979.0	8,709.0	9,211.0	18,450.0	8,804.0	6,140.0	4,882.0	4,597.0	4,892.0	4,642.0	4,690.0

LEGEND \* - Recorder malfunction during part of month. Partial data is available.

Note : All figures are in terms of daily amounts, i.e., Mean Daily, Maximum Daily & Minimum Daily.

# WALNUT CREEK above Puente Avenue STATION NO. F304-R

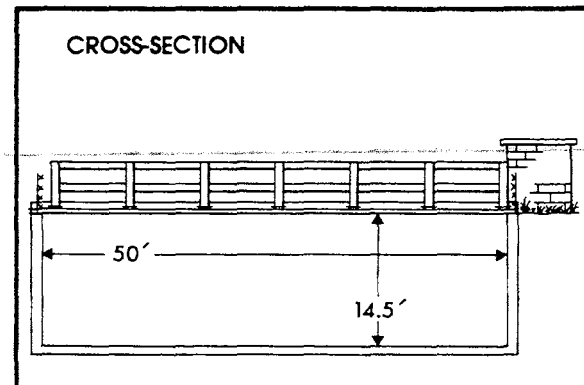
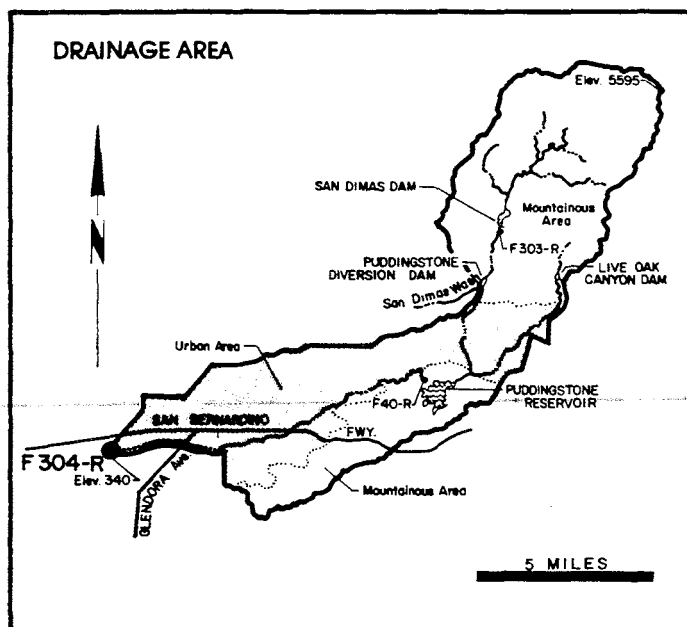
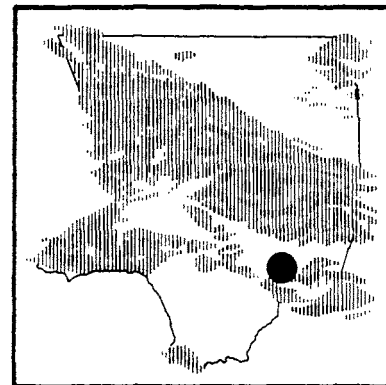

RECORDER- continuous water stage.  
 METHOD OF MEASUREMENTS- wading or from footbridge.  
 DRAINAGE AREA- 57.6 square miles.  
 LOCATION- 845.0 feet upstream of Puente Avenue bridge, Baldwin Park.  
 REGULATION- partially regulated by San Dimas, Puddingstone Diversion, Puddingstone, and Live Oak Dams.  
 CHANNEL- concrete, rectangular in section.  
 CONTROL- channel forms control.  
 LENGTH OF RECORD- October 14, 1952 to April 11, 1961, January 3, 1962 to date.  
 REMARKS- no record during April 11, 1961 to January 3, 1962 due to channel construction.

## WATER YEAR 1994-1995 (DISCHARGE IN CFS)

MONTH	OCT	NOV	DEC	JAN	FEB	MAR	APR	MAY	JUN	JUL	AUG	SEP
MEAN	4.8	4.1	5.1	69.5	25.6	166.0	7.3	1.7	6.8	2.0	1.0	1.1
MAX	83.8	62.2	50.7	741.0	304.0	900.0	93.1	3.1	181.0	4.5	3.8	3.0
MIN	0.1	0.6	0.2	0.1	0.9	0.1	0.0	1.3	0.0	0.0	0.5	0.5
TOTAL AF	296.0	243.0	312.0	4,276.0	1,422.0	10,230.0	434.0	102.0	406.0	122.0	64.0	63.0

## WATER YEAR 1995-1996 (DISCHARGE IN CFS)

MONTH	OCT	NOV	DEC	JAN	FEB	MAR	APR	MAY	JUN	JUL	AUG	SEP
MEAN	1.1	0.7	5.0	25.9	144.0	23.3	7.3	0.9	0.2	0.2	0.4	0.8
MAX	1.7	2.0	75.1	596.0	1,200.0	327.0	31.8	4.6	0.5	0.8	1.4	3.7
MIN	0.8	0.4	0.5	0.6	13.6	1.6	1.5	0.1	0.1	0.0	0.1	0.3
TOTAL AF	68.0	41.0	307.0	1,592.0	8,310.0	1,433.0	436.0	55.0	10.7	13.3	27.2	45.8

Note : All figures are in terms of daily amounts, i.e., Mean Daily, Maximum Daily & Minimum Daily.

# SAN JOSE CHANNEL above Workman Mill Road STATION NO. F312-R

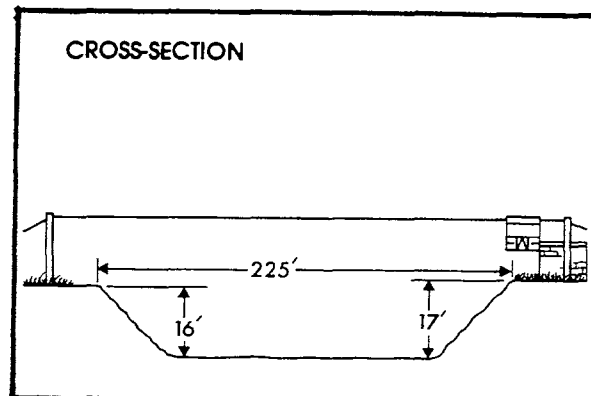
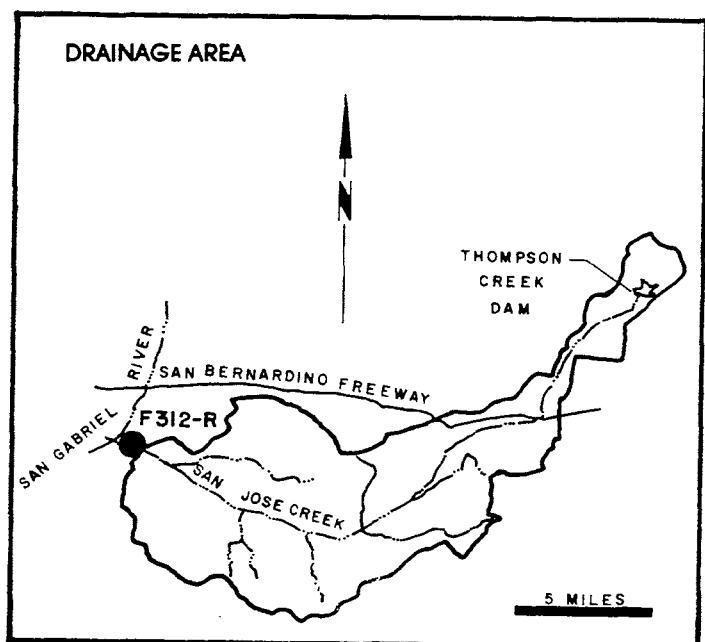
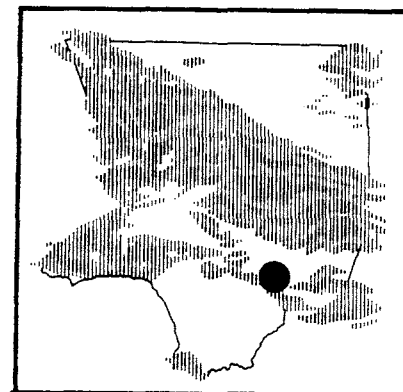

RECORDER- continuous water stage.

METHOD OF MEASUREMENTS- wading or from cable car.

DRAINAGE AREA- 83.4 square miles.

LOCATION- 1,650 feet above Workman Mill Road, 3.0 miles southeast of El Monte.

REGULATION- partially regulated by Thompson Creek Dam and Pomona Sewage Treatment Plant.

CHANNEL- grouted rip-rap side slopes with natural bottom, trapezoidal section.

CONTROL- rock stabilizer.

LENGTH OF RECORD- September 13, 1955 to date.

## WATER YEAR 1994-1995 (DISCHARGE IN CFS)

MONTH	OCT	NOV	DEC	JAN	FEB	MAR	APR	MAY	JUN	JUL	AUG	SEP
MEAN	158.0	160.0	133.0	296.0	63.9	178.0	57.1	41.7	59.0	37.5	29.1	33.1
MAX.	261.0	333.0	328.0	2,480.0	566.0	1,450.0	343.0	53.2	573.0	49.1	33.9	42.4
MIN	104.0	23.6	26.2	33.7	36.1	22.7	37.6	36.2	34.1	27.0	27.0	27.1
TOTAL AF	9,717.0	9,524.0	8,171.0	18,230.0	3,549.0	10,940.0	3,395.0	2,565.0	3,513.0	2,309.0	1,786.0	1,967.0

## WATER YEAR 1995-1996 (DISCHARGE IN CFS)

MONTH	OCT	NOV	DEC	JAN	FEB	MAR	APR	MAY	JUN	JUL	AUG	SEP
MEAN	22.2	19.7	27.1	55.5	132.0	66.2	75.0	67.0	27.5	16.0	13.7	15.9
MAX.	27.7	31.5	231.0	766.0	1,630.0	580.0	204.0	93.8	104.0	19.1	16.1	20.3
MIN	15.9	11.1	6.1	8.8	0.0	20.3	17.1	48.0	12.0	15.4	11.7	12.3
TOTAL AF	1,363.0	1,173.0	1,664.0	3,410.0	7,595.0	4,068.0	4,460.0	4,120.0	1,637.0	982.0	843.0	944.0

Note : All figures are in terms of daily amounts, i.e., Mean Daily, Maximum Daily & Minimum Daily.



# ARCADIA WASH below Grand Avenue STATION NO. F 317-R

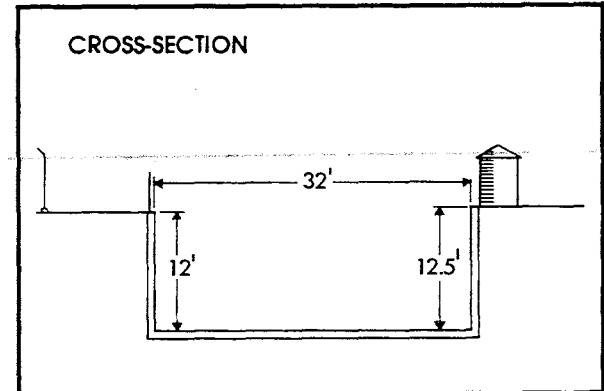
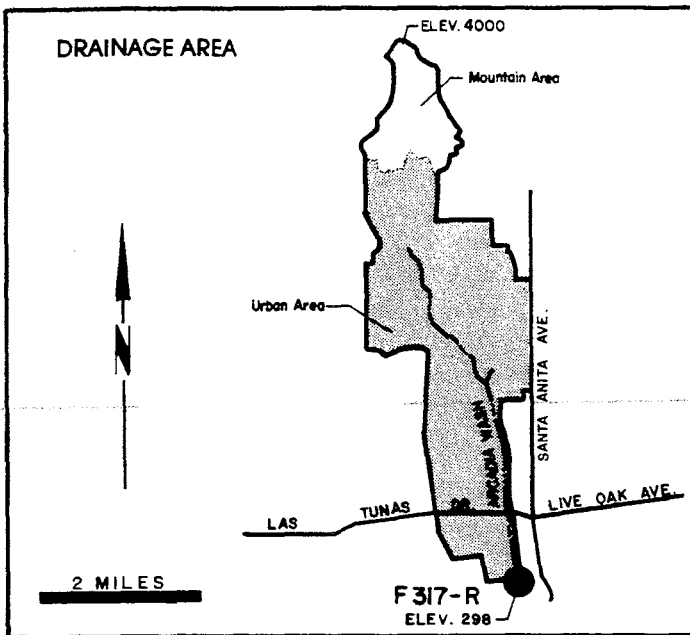
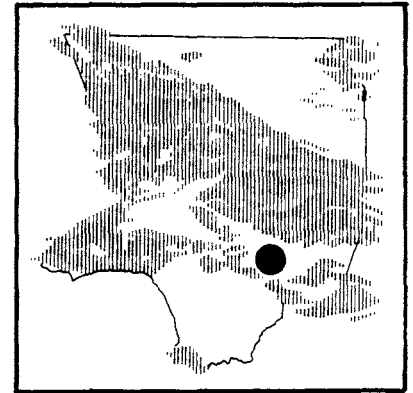

RECORDER- 15 minute punched tape.

METHOD OF MEASUREMENTS- low flows measured by wading. High flows measured from upstream side of Grand Avenue bridge.

DRAINAGE AREA- 8.5 square miles.

LOCATION- on the west wall of Arcadia Wash about 75 feet downstream from centerline of Grand Avenue.

REGULATION- several debris basins located upstream.

CHANNEL- rectangular concrete.

LENGTH OF RECORD- December 12, 1955 to date.

## WATER YEAR 1994-1995 (DISCHARGE IN CFS)

MONTH	OCT	NOV	DEC	JAN	FEB	MAR	APR	MAY	JUN	JUL	AUG	SEP
MEAN	2.6	2.0	5.7	54.9	12.9	32.4	12.3	2.5	4.2	1.0	0.7	1.3
MAX	48.4	40.5	59.0	480.0	171.0	250.0	103.0	18.6	72.5	1.4	0.9	2.8
MIN	0.4	0.1	0.5	0.5	0.1	1.0	1.5	1.1	0.7	0.8	0.5	0.6
TOTAL AF	159.0	120.0	349.0	3,374.0	718.0	1,990.0	731.0	154.0	251.0	63.0	44.0	79.0

## WATER YEAR 1995-1996 (DISCHARGE IN CFS)

MONTH	OCT	NOV	DEC	JAN	FEB	MAR	APR	MAY	JUN	JUL	AUG	SEP
MEAN	1.3	1.5	4.2	3.7	30.1	13.3	3.7	1.4	1.3	0.7	1.2	0.9
MAX	1.5	2.2	54.5	57.4	405.0	163.0	35.0	2.3	3.5	1.3	2.0	1.6
MIN	1.2	1.2	0.9	0.7	0.5	0.9	0.5	0.8	0.6	0.4	0.7	0.6
TOTAL AF	82.0	92.0	255.0	230.0	1,731.0	819.0	220.0	87.0	78.1	41.9	75.2	53.2

Note : All figures are in terms of daily amounts, i.e., Mean Daily, Maximum Daily & Minimum Daily.

# EATON WASH at Loftus Drive STATION NO. F318-R

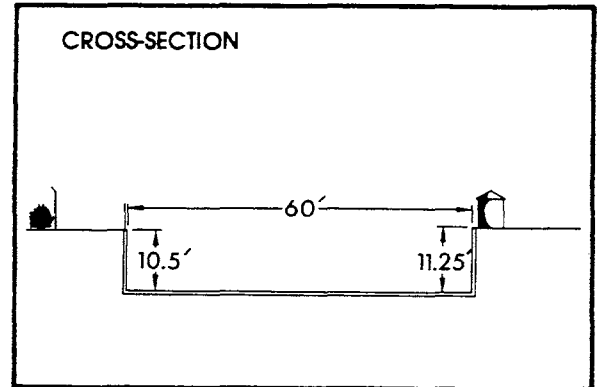
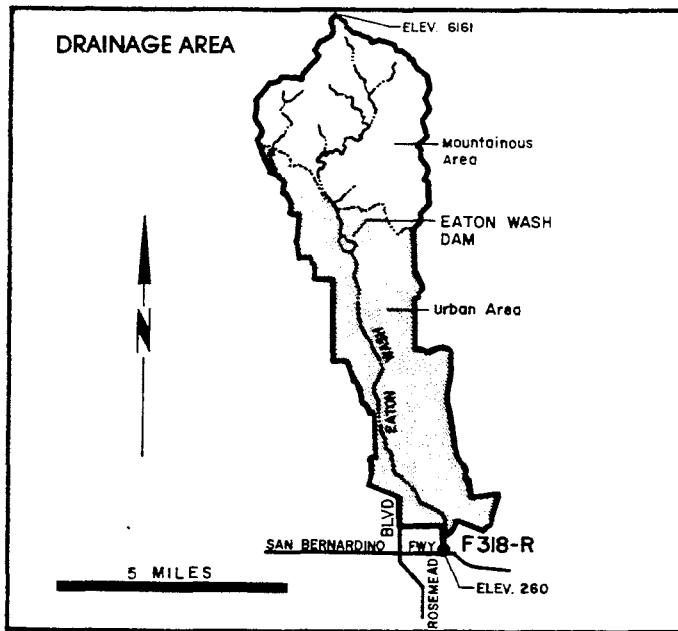
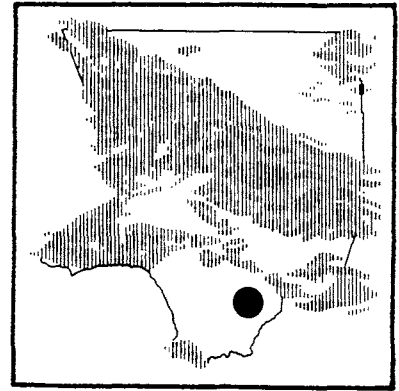

RECORDER- 15 minute punched tape.

METHOD OF MEASUREMENTS- low flows measured by wading. High flows measured from upstream side of East Loftus Drive bridge.

DRAINAGE- 22.8 square miles.

LOCATION- on the west wall of the channel 52 feet above the centerline of East Loftus Drive bridge, 1.3 miles west of El Monte.

REGULATION- partly regulated by Eaton Dam.

DIVERSIONS- the Pasadena Water Department diverts some water just above the mouth of Eaton Canyon. The Flood Control District diverts water to spreading grounds below Eaton Dam and below Huntington Drive.

CHANNEL- rectangular concrete, 60 feet wide, 11.3 feet.

CONTROL- channel forms control.

LENGTH OF RECORD- 1956 to date.

## WATER YEAR 1994-1995 (DISCHARGE IN CFS)

MONTH	OCT	NOV	DEC	JAN	FEB	MAR	APR	MAY	JUN	JUL	AUG	SEP
MEAN	1.7	2.5	4.5	103.0	19.6	86.2	7.5	0.5	9.1	0.1	2.0	1.7
MAX.	31.5	64.3	84.6	954.0	270.0	561.0	92.2	6.4	172.0	0.4	8.4	8.6
MIN	0.0	0.0	0.0	0.0	0.0	0.2	0.0	0.1	0.1	0.0	0.1	0.3
TOTAL AF	104.0	147.0	275.0	6,336.0	1,089.0	5,300.0	446.0	34.0	539.0	7.0	125.0	99.0

## WATER YEAR 1995-1996 (DISCHARGE IN CFS)

MONTH	OCT	NOV	DEC	JAN	FEB	MAR	APR	MAY	JUN	JUL	AUG	SEP
MEAN	2.8	0.6	6.1	16.6	50.8	14.7	2.6	0.4	0.4	0.4	1.0	0.4
MAX.	8.6	3.9	88.1	356.0	551.0	255.0	32.7	0.6	0.6	0.7	4.5	0.5
MIN	0.1	0.1	0.1	0.1	0.1	0.1	0.1	0.4	0.2	0.3	0.3	0.3
TOTAL AF	175.0	34.0	373.0	1,019.0	2,924.0	902.0	152.0	26.0	22.2	23.0	59.9	23.2

Note: All figures are in terms of daily amounts, i.e., Mean Daily, Maximum Daily & Minimum Daily.

# LOS ANGELES RIVER below Wardlow Road STATION NO. F319-R

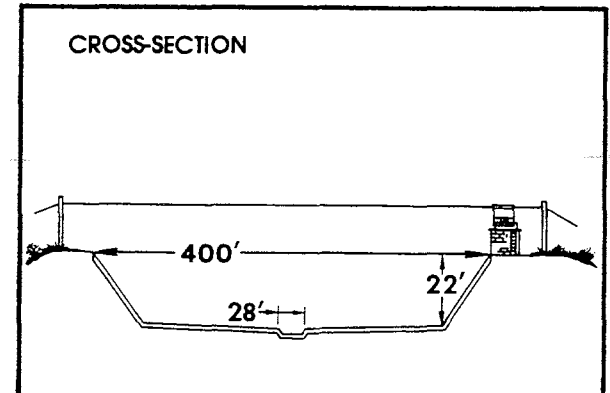
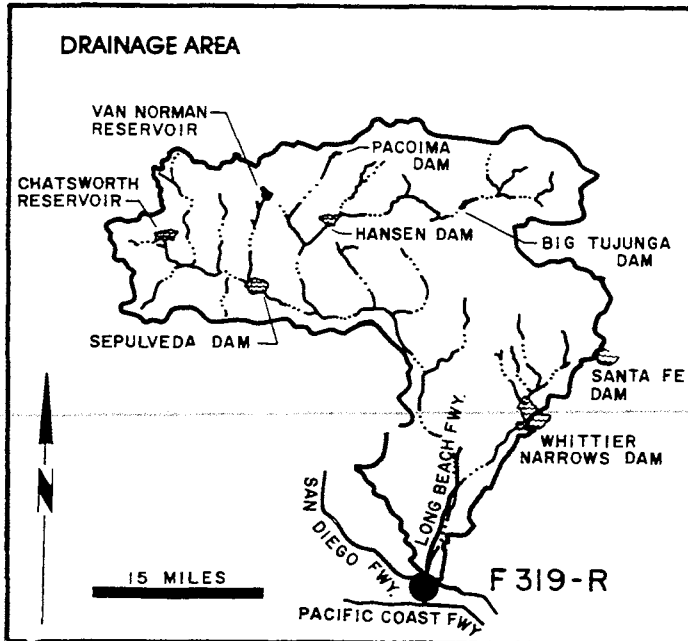
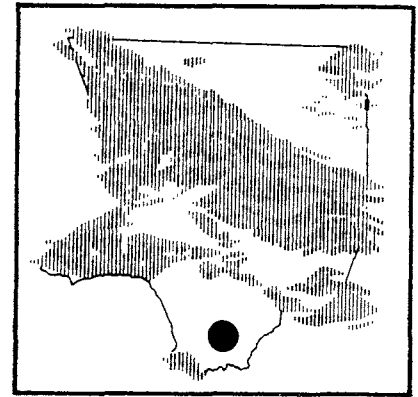

RECORDER- continuous water stage.

METHOD OF MEASUREMENTS- wading or from cable car.

DRAINAGE AREA- 815.0 square miles (excludes area above Santa Fe Dam).

LOCATION- 900.0 feet below Wardlow Road, Long Beach.

REGULATION- flow is subject to the same regulation as Stations F34D-R and P458-R.

DIVERSIONS- flows diverted to Dominguez Gap Spreading Grounds.

CHANNEL- trapezoidal, concrete, 302.0 feet wide at bottom with 2.25:1 side slopes. Low flow channel 28.0 feet wide by 1.0 foot deep in center of channel.

CONTROL- channel forms control.

LENGTH OF RECORD- at Station F180-R October 31, 1931 to January 13, 1956. at Station F319-R January 13, 1956 to date.

REMARKS- prior to 1931, see Station F36-R.

## WATER YEAR 1994-1995 (DISCHARGE IN CFS)

MONTH	OCT	NOV	DEC	JAN	FEB	MAR	APR	MAY	JUN	JUL	AUG	SEP
MEAN	204.0	240.0	449.0	5,308.0	802.0	3,637.0	298.0	*	*	143.0	138.0	139.0
MAX	1,120.0	1,770.0	4,420.0	43,900.0	9,590.0	32,200.0	2,080.0	*	*	149.0	145.0	145.0
MIN	131.0	136.0	121.0	206.0	234.0	261.0	194.0	*	*	138.0	129.0	129.0
TOTAL AF	12,560.0	14,300.0	27,590.0	326,400.0	44,530.0	223,600.0	17,700.0	*	*	8,817.0	8,481.0	8,249.0

## WATER YEAR 1995-1996 (DISCHARGE IN CFS)

MONTH	OCT	NOV	DEC	JAN	FEB	MAR	APR	MAY	JUN	JUL	AUG	SEP
MEAN	131.0	146.0	*	*	1,103.0	388.0	173.0	124.0	124.0	129.0	135.0	128.0
MAX	137.0	185.0	*	*	15,100.0	2,680.0	699.0	124.0	124.0	165.0	160.0	156.0
MIN	127.0	132.0	*	*	111.0	124.0	117.0	124.0	124.0	102.0	96.8	111.0
TOTAL AF	8,081.0	8,674.0	*	*	63,460.0	23,870.0	10,270.0	7,624.0	7,379.0	7,954.0	8,314.0	7,605.0

LEGEND \* - Recorder malfunctioned during part of the month. Partial data is available.

Note : All figures are in terms of daily amounts, i.e., Mean Daily, Maximum Daily & Minimum Daily.

# MINT CANYON CREEK at Finch Avenue STATION NO. F328-R

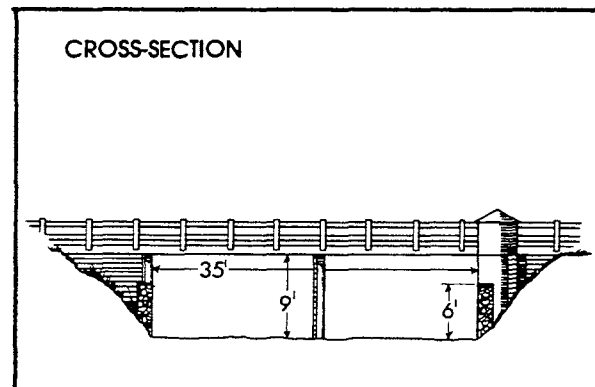
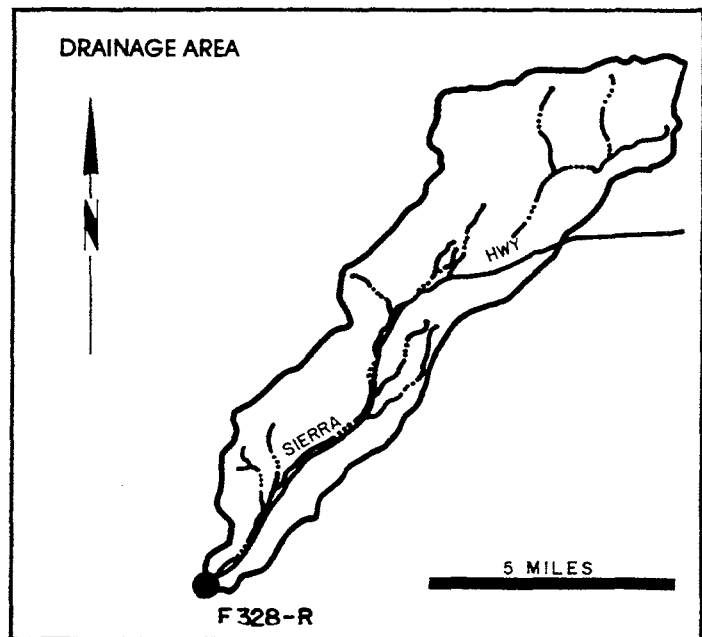
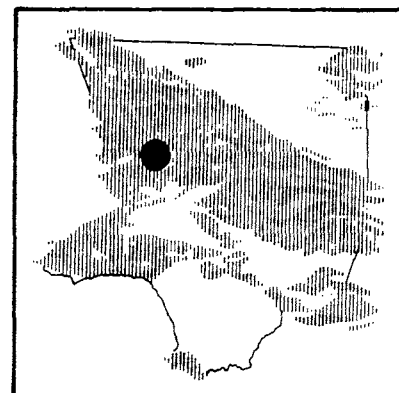

RECORDER- continuous water stage.  
 METHOD OF MEASUREMENTS- wading or from bridge.  
 DRAINAGE AREA- 26.9 square miles.  
 LOCATION- 8.5 miles northeast of Saugus on west end of Finch Avenue bridge.  
 REGULATION- none.  
 CHANNEL- natural, sand and gravel.  
 CONTROL- concrete control at downstream end of bridge.  
 LENGTH OF RECORD- October 26, 1956 to date.

## WATER YEAR 1994-1995 (DISCHARGE IN CFS)

MONTH	OCT	NOV	DEC	JAN	FEB	MAR	APR	MAY	JUN	JUL	AUG	SEP
MEAN	0.1	0.1	0.1	4.3	0.6	*	*	*	0.4	0.1	0.3	0.2
MAX	0.1	0.1	0.2	43.5	5.2	*	*	*	1.0	0.2	0.7	0.4
MIN	0.1	0.1	0.1	0.0	0.0	*	*	*	0.1	0.0	0.2	0.1
TOTAL AF	6.0	6.0	6.0	266.0	31.0	*	*	*	25.0	9.0	17.0	11.0

## WATER YEAR 1995-1996 (DISCHARGE IN CFS)

MONTH	OCT	NOV	DEC	JAN	FEB	MAR	APR	MAY	JUN	JUL	AUG	SEP
MEAN	*	*	*	*	5.0	0.7	0.4	0.1	0.1	0.0	*	*
MAX	*	*	*	*	60.4	3.7	0.6	0.2	0.2	0.2	*	*
MIN	*	*	*	*	0.0	0.3	0.1	0.0	0.1	0.0	*	*
TOTAL AF	*	*	*	*	287.0	46.0	22.0	8.0	6.0	3.0	*	*

LEGEND \* - Recorder malfunctioned during part of the month. Partial data is available.

Note : All figures are in terms of daily amounts, i.e., Mean Daily, Maximum Daily & Minimum Daily.

# BRADBURY CHANNEL

## below Central Avenue

### STATION NO. F329-R

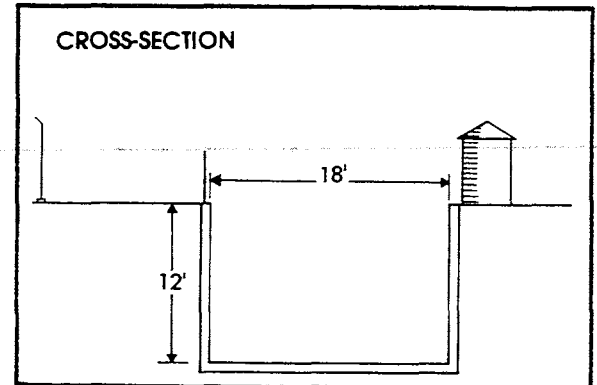
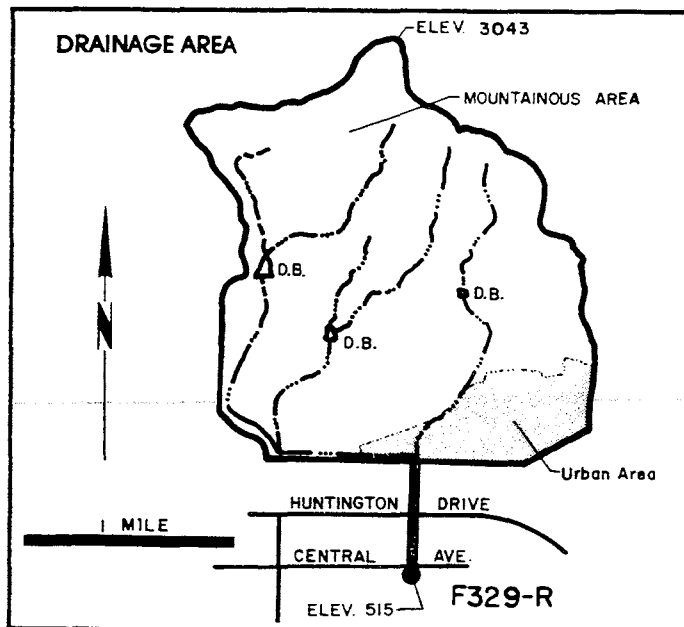
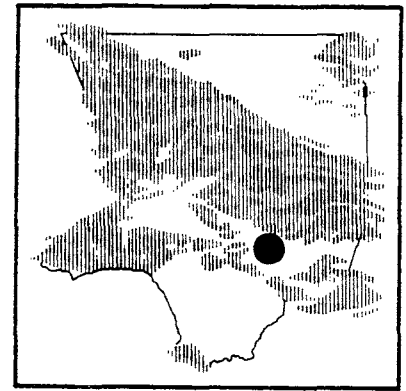

RECORDER- 15 minute punched tape.

METHOD OF MEASUREMENT- low flows measured by wading. High flows measured from footbridge four feet downstream from recorder.

DRAINAGE AREA- 3.3 square miles.

LOCATION- on the east wall of Bradbury Channel, 200 feet downstream from the centerline of Central Avenue, one mile east of Duarte.

REGULATION- two debris basins located upstream.

CHANNEL- rectangular concrete, 18 feet wide, 12 feet deep.

CONTROL- channel forms control.

LENGTH OF RECORD- June 14, 1957 to present.

### WATER YEAR 1994-1995 (DISCHARGE IN CFS)

MONTH	OCT	NOV	DEC	JAN	FEB	MAR	APR	MAY	JUN	JUL	AUG	SEP
MEAN	0.4	0.2	0.6	6.1	1.9	9.4	2.4	3.5	2.0	0.5	0.1	0.1
MAX	8.3	4.6	10.0	82.7	26.6	64.9	9.3	7.6	11.8	1.2	0.4	0.5
MIN	0.0	0.0	0.0	0.0	0.3	0.5	0.6	1.0	0.0	0.0	0.0	0.0
TOTAL AF	25.0	11.0	37.0	373.0	108.0	580.0	140.0	214.0	118.0	33.0	5.0	9.0

### WATER YEAR 1995-1996 (DISCHARGE IN CFS)

MONTH	OCT	NOV	DEC	JAN	FEB	MAR	APR	MAY	JUN	JUL	AUG	SEP
MEAN	0.6	0.1	0.5	0.5	9.4	2.7	1.8	1.9	2.5	0.2	0.8	0.5
MAX	1.8	0.3	6.5	6.0	97.6	37.2	4.5	5.8	12.3	1.8	1.6	1.0
MIN	0.0	0.0	0.1	0.1	0.1	0.1	0.2	0.2	0.1	0.0	0.1	0.1
TOTAL AF	39.0	6.0	32.0	32.0	543.0	168.0	106.0	116.0	151.0	13.9	49.6	28.0

Note : All figures are in terms of daily amounts, i.e., Mean Daily, Maximum Daily & Minimum Daily.



# RUBIO DIVERSION CHANNEL

## below Goosebury Inlet

### STATION NO. F338-R

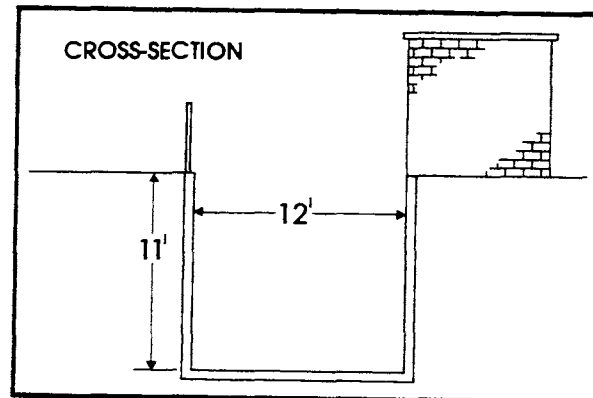
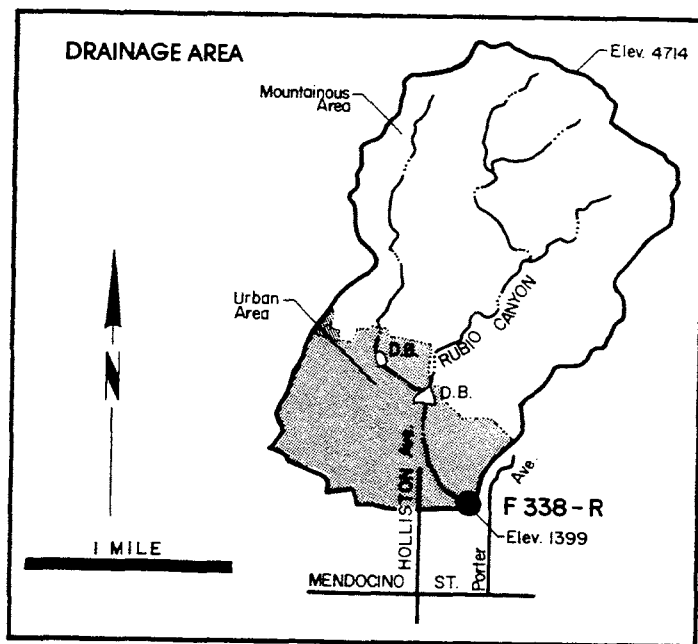
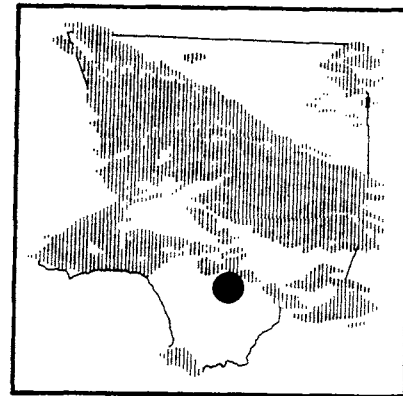

RECORDER- 15 minute punched tape.

METHOD OF MEASUREMENTS- low flows measured by wading. High flows measured from steel footbridge 27 feet above station.

DRAINAGE AREA- 2.1 square miles.

LOCATION- on the north bank, 375 feet upstream of Crest Drive, three and one-half miles northeast of Pasadena.

REGULATION- flow partially regulated by Rubio and Gooseberry Debris Basins.

DIVERSIONS- Rubio Canyon Land and Water Association diverts low flows in Rubio Canyon.

CHANNEL- rectangular concrete, 12 feet wide and 11 feet deep.

CONTROL- channel forms control.

LENGTH OF RECORD- December 16, 1959 to date.

### WATER YEAR 1994-1995 (DISCHARGE IN CFS)

MONTH	OCT	NOV	DEC	JAN	FEB	MAR	APR	MAY	JUN	JUL	AUG	SEP
MEAN	0.5	0.4	0.7	9.2	10.5	6.1	3.2	0.9	1.3	0.6	0.6	0.6
MAX	2.1	1.1	2.0	25.8	64.8	71.6	6.6	1.6	2.3	1.5	1.5	1.5
MIN	0.1	0.2	0.2	0.8	1.6	2.4	1.0	0.4	0.2	0.0	0.2	0.2
TOTAL AF	28.0	21.0	42.0	568.0	584.0	377.0	188.0	57.0	79.0	38.0	39.0	35.0

### WATER YEAR 1995-1996 (DISCHARGE IN CFS)

MONTH	OCT	NOV	DEC	JAN	FEB	MAR	APR	MAY	JUN	JUL	AUG	SEP
MEAN	0.5	0.5	1.2	1.8	5.2	3.9	3.6	0.8	0.6	*	0.2	0.3
MAX	1.2	1.0	7.1	15.8	41.2	12.0	5.7	1.9	1.4	*	1.1	0.7
MIN	0.2	0.2	0.2	0.2	1.0	1.8	2.8	0.2	0.2	*	0.0	0.0
TOTAL AF	33.0	29.0	77.0	112.0	297.0	241.0	214.0	48.0	36.0	*	13.0	15.0

LEGEND \* - Recorder malfunctioned during part of the month. Partial data is available.

Note : All figures are in terms of daily amounts, i.e., Mean Daily, Maximum Daily & Minimum Daily.

# BRANFORD STREET CHANNEL

## below Sharp Avenue

### STATION NO. F342-R

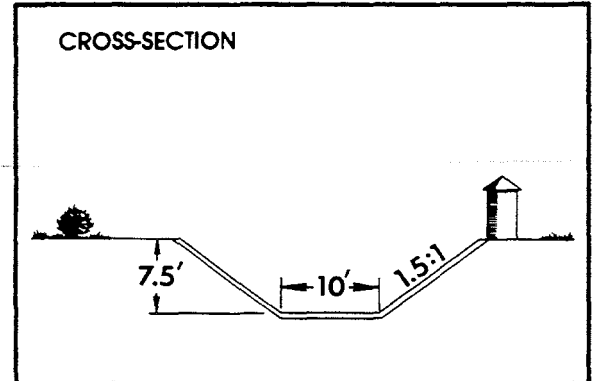
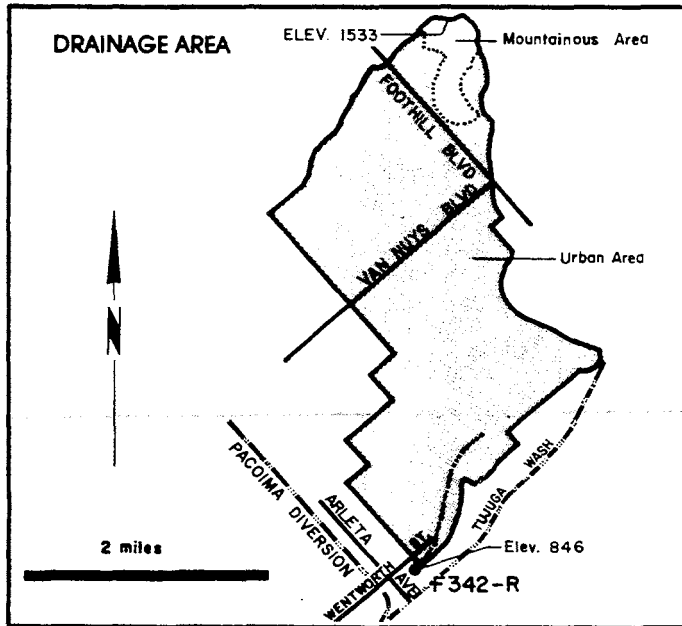
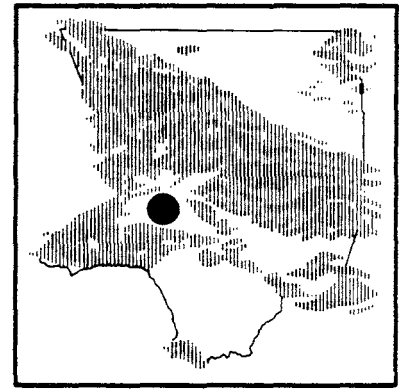

RECORDER- 15 minute punched tape.

METHOD OF MEASUREMENTS- low flows measured by wading. High flows measured by floats.

DRAINAGE AREA- 5.01 square miles.

LOCATION- on the south bank of channel, 125 feet downstream from Sharp Avenue, about 3.6 miles south of San Fernando.

REGULATION- flow from Lopez Creek is diverted to Hansen Dam at the mouth of Lopez Canyon.

CHANNEL- trapezoidal, 10 feet wide at bottom and 7.5 feet deep with 1.5 to 1 side slopes.

CONTROL- channel forms control.

LENGTH OF RECORD- January 12, 1962 to date.

### WATER YEAR 1994-1995 (DISCHARGE IN CFS)

MONTH	OCT	NOV	DEC	JAN	FEB	MAR	APR	MAY	JUN	JUL	AUG	SEP
MEAN	*	*	1.7	15.7	2.3	9.6	1.4	0.3	0.8	0.4	0.3	0.2
MAX	*	*	40.2	175.0	47.1	105.0	27.7	1.0	10.5	0.4	0.4	0.3
MIN	*	*	0.0	0.0	0.0	0.1	0.1	0.3	0.3	0.3	0.2	0.1
TOTAL AF	*	*	105.0	967.0	128.0	588.0	81.0	21.0	47.0	22.0	17.0	12.0

### WATER YEAR 1995-1996 (DISCHARGE IN CFS)

MONTH	OCT	NOV	DEC	JAN	FEB	MAR	APR	MAY	JUN	JUL	AUG	SEP
MEAN	0.2	0.3	1.5	1.7	4.9	1.2	0.5	0.2	0.1	0.1	0.1	0.1
MAX	0.3	0.5	17.8	31.8	68.4	16.1	4.1	0.9	0.2	0.1	0.1	0.2
MIN	0.1	0.3	0.2	0.1	0.2	0.2	0.2	0.2	0.0	0.0	0.1	0.1
TOTAL AF	14.0	18.0	89.0	105.0	283.0	76.0	27.0	14.0	7.0	6.0	6.0	6.0

LEGEND \* - Recorder malfunction during part of month. Partial data is available.

Note : All figures are in terms of daily amounts, i.e., Mean Daily, Maximum Daily & Minimum Daily.

# COYOTE CREEK below Spring Street STATION NO. F354-R

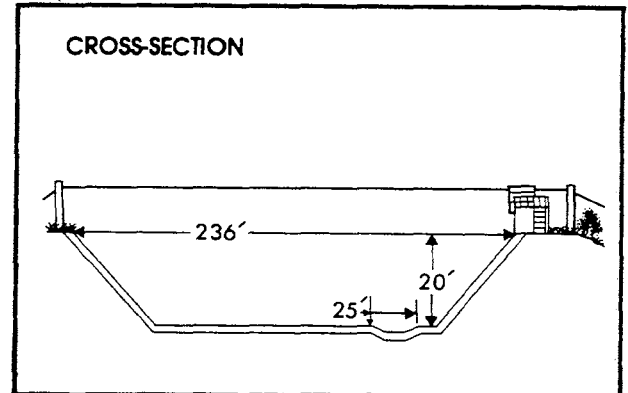
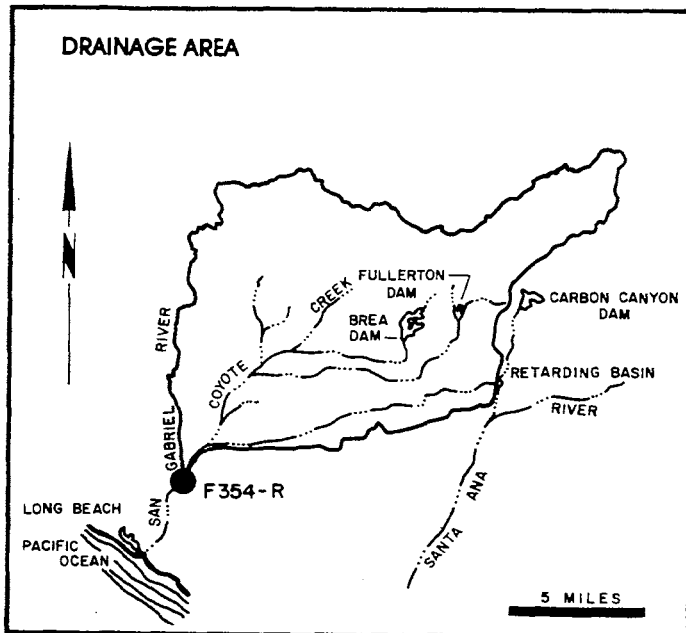
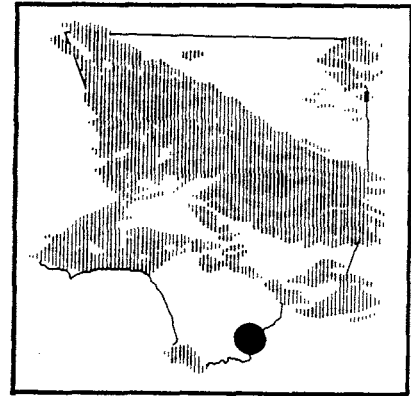

RECORDER- continuous water stage.

METHOD OF MEASUREMENTS- wading or from cable car.

DRAINAGE AREA- 185.0 square miles.

LOCATION- 241.0 feet below Spring Street, 7.5 miles northeast of Long Beach.

REGULATION- partially regulated by Fullerton Dam, Brea Dam, and Carbon Canyon Dam.

CHANNEL- concrete, trapezoidal in section.

CONTROL- channel forms control.

LENGTH OF RECORD - December 17, 1963 to date.

REMARKS- previous gaging stations for record correlation: Station F41 - S December 1, 1928 to January 14, 1930. Station F41 - R January 14, 1930 to October 30, 1936. Station F41B - R October 30, 1936 to February 17, 1937. Station F41C - R February 18, 1937 to February 8, 1956. Station F320 - R February 9, 1956 to July 2, 1965.

## WATER YEAR 1994-1995 (DISCHARGE IN CFS)

MONTH	OCT	NOV	DEC	JAN	FEB	MAR	APR	MAY	JUN	JUL	AUG	SEP
MEAN	OUT	7.6	38.7	286.0	47.8	363.0	*	*	37.2	16.2	7.8	12.7
MAX	OF	29.5	232.0	1,980.0	834.0	3,440.0	*	*	656.0	20.5	15.0	19.1
MIN	SERVICE	0.0	1.5	10.6	9.4	25.9	*	*	8.1	8.7	3.6	10.1
TOTAL AF		450.0	2,382.0	17,580.0	2,654.0	22,300.0	*	*	2,213.0	998.0	480.0	753.0

## WATER YEAR 1995-1996 (DISCHARGE IN CFS)

MONTH	OCT	NOV	DEC	JAN	FEB	MAR	APR	MAY	JUN	JUL	AUG	SEP
MEAN	12.8	6.7	20.2	81.0	189.0	98.4	28.2	*				*
MAX	19.2	20.4	420.0	1,150.0	2,990.0	420.0	321.0	*	NO DATA AVAILABLE			*
MIN	7.8	5.2	2.8	5.4	3.2	5.8	3.5	*				*
TOTAL AF	787.0	397.0	1,240.0	4,983.0	10,900.0	6,053.0	1,681.0	*				*

LEGEND \* - Recorder malfunctioned during part of the month. Partial data is available.

Note : All figures are in terms of daily amounts, i.e., Mean Daily, Maximum Daily & Minimum Daily.

# BOUQUET CANYON CREEK

## at Urbandale Avenue

### STATION NO. F377-R

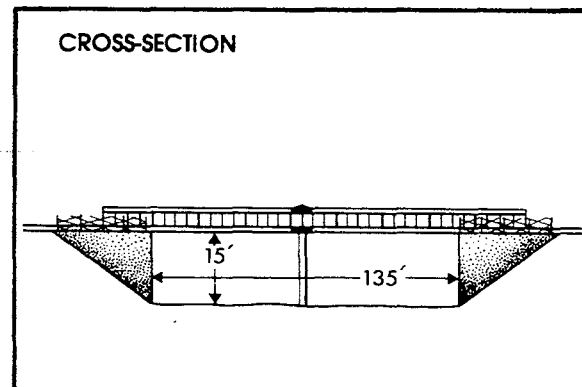
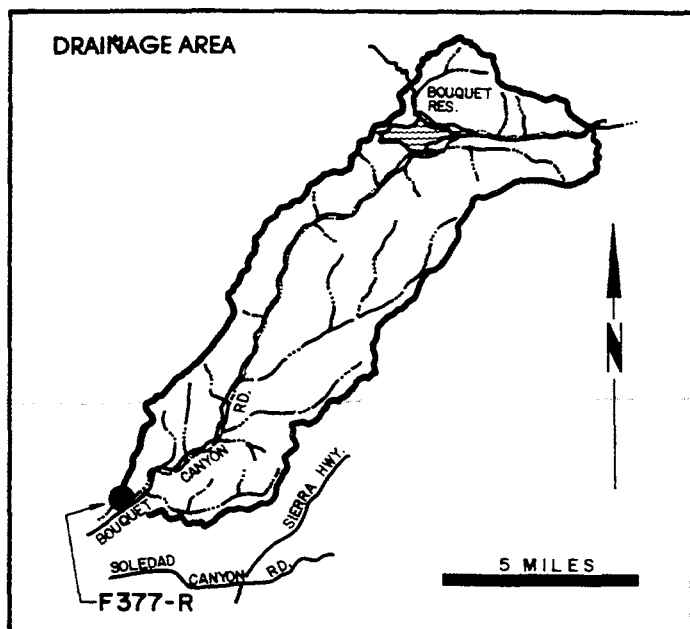
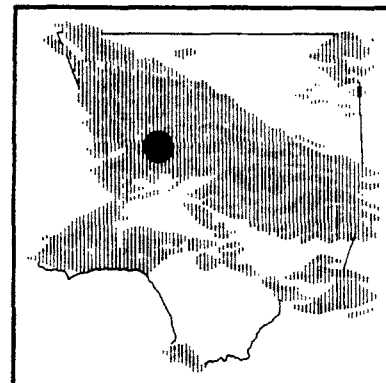

RECORDER- continuous water stage.

METHOD OF MEASUREMENTS- wading or from bridge.

DRAINAGE AREA- 51.9 square miles.

LOCATION- Bouquet Canyon Creek at Urbandale Avenue, 3.5 miles northeast of Saugus.

REGULATION- Bouquet Reservoir.

CHANNEL- concrete sides with natural bottom, trapezoidal in section.

CONTROL- concrete stabilizer.

LENGTH OF RECORD- October 11, 1967 to date.

### WATER YEAR 1994-1995 (DISCHARGE IN CFS)

MONTH	OCT	NOV	DEC	JAN	FEB	MAR	APR	MAY	JUN	JUL	AUG	SEP
MEAN	*	0.0	0.0	17.5	1.4	6.7	0.5	1.4	0.4	0.3	0.4	0.3
MAX.	*	0.1	0.0	302.0	17.6	88.2	2.2	2.7	1.7	1.9	0.9	2.5
MIN	*	0.0	0.0	0.0	0.0	0.0	0.0	0.1	0.0	0.0	0.0	0.0
TOTAL AF	*	1.0	0.0	1,076.0	77.0	410.0	32.0	84.0	26.0	21.0	25.0	18.0

### WATER YEAR 1995-1996 (DISCHARGE IN CFS)

MONTH	OCT	NOV	DEC	JAN	FEB	MAR	APR	MAY	JUN	JUL	AUG	SEP
MEAN	0.2	0.7	1.6	0.9	4.0	1.1	0.3	0.4	0.0	0.0	0.0	0.0
MAX.	2.9	8.0	7.9	13.8	38.3	9.2	0.8	1.1	0.1	0.0	0.0	0.0
MIN	0.0	0.0	0.5	0.2	0.1	0.0	0.2	0.0	0.0	0.0	0.0	0.0
TOTAL AF	12.0	41.0	101.0	53.0	230.0	67.0	17.0	22.0	0.0	0.0	0.0	0.0

LEGEND \* - Recorder malfunctioned during part of the month. Partial data is available.

Note : All figures are in terms of daily amounts, i.e., Mean Daily, Maximum Daily & Minimum Daily.

# RESERVOIRS



## **RESERVOIRS**

Following the damaging flood of 1914 and creation of the Los Angeles County Flood Control District in 1915, a program of flood control and water conservation was initiated. Part of this program included the construction of 15 dams which were completed between 1920 and 1939. These dams were operated by the Department during the period covered by this report. In addition, five Corps of Engineers' dams, Lopez, Hansen, Santa Fe, Sepulveda and Whittier Narrows Dams, were operated by the Corps in conjunction with the Department dams to achieve flood control and/or water conservation. On November 7, 1995, the Metropolitan Water District of Southern California (MWD) transferred ownership of Morris Dam to the Department.

### **OPERATION**

The Department operates its reservoirs to control flood waters during storm periods. The Department makes post storm releases, when feasible, in amounts that can be conserved in downstream spreading grounds and by channel percolation.

### **RECORDS**

The storage and flow records at the 15 Department reservoirs are summarized on the Dam Operation Record Sheets. The sheets show:

1. Daily reservoir water surface elevations. Elevations are obtained from water stage recorder graphs or interpolation from staff gage readings and recorded as of midnight of each day. Only maximum and minimum water surface elevations for each year are shown.
2. Available storage in acre-feet based on the most recent topographic surveys. Annual storage volumes are shown.
3. Stream inflow rates in cubic feet per second. This is usually calculated from storage change and known outflow.
4. Outflow in cubic feet per second. These values are determined from gaging station records, or when these are not available, from valve and spillway rating curves. Only the maximum and minimum of the daily outflow rates for the year and the instantaneous peak outflow rate are shown.
5. Discrepancies between outflow and storage losses are attributable to evaporation and/or percolation losses. Total monthly evaporation losses are determined from the measurements made on land evaporation pans. In those cases where no allowances were made for evaporation, the amounts are necessarily included in the flow values. Accuracy of flow records computed from storage records is dependent on the frequency with which storage data are revised to keep in step with the physical change in reservoirs due to sediment deposition, accumulation and removal.

## **RESERVOIR CLEANOUTS**

The periodical removal of sediment from our reservoirs is necessary to maintain storage capacity. Sediment deposition adversely affects flood control and water conservation storage activities in our reservoirs. The 1992 and 1993 storms were declared disaster events by the State and Federal Governments, and therefore removal of portions of the total sediment inflow for the 1992-93 and 1993-94 storm seasons were eligible for reimbursement by the Federal Emergency Management Agency (FEMA).

Between June 1993 and June 1994 the Department completed seven cleanouts. These cleanouts removed approximately 845,000 Cubic Yards (C.Y.) of sediment from our reservoirs at the cost of \$5.2 million. Eaton Wash Reservoir cleanout removed 314,000 C.Y. of sediment. San Dimas Reservoir cleanout removed 84,000 C.Y. of sediment. Santa Anita Reservoir cleanout removed 73,000 C.Y. of sediment. Puddingstone Reservoir cleanout removed 114,000 C.Y. of sediment. Big Dalton Sediment cleanout removed 43,000 C.Y. of sediment. Live Oak removed 24,000 C.Y. of sediment. The Devil's Gate cleanout removed 193,000 C.Y. of sediment.

In June 1994 the Department initiated three large-scale cleanout projects at Big Tujunga and Cogswell Reservoirs and at the Whittier Narrows Flood Control Basin. The Department completed the Big Tujunga and Whittier Narrows projects in Autumn 1995. These projects removed about 773,000 C.Y. and 838,000 C.Y. respectively, at a combined cost of \$11.2 million. The Department anticipates completing the Cogswell project by the end of 1996 at a cost of about \$12 million.

The Department is currently preparing a long-term Sediment Management Plan (SMP) for the San Gabriel Canyon, which includes Cogswell, San Gabriel, and Morris Reservoirs. During the public review period for SMP's environmental documents (Environmental Impact Report/Environmental Impact Statement), a concern was raised about the possibility that the sediment within Morris Reservoir may have been contaminated by past naval activities at the facility. As a result, the Department hired a consultant to conduct a sediment testing program.

Our consultant Fugro-West, Inc. completed the Morris Reservoir sediment sampling program in October 1994. The consultant collected for chemical analysis a total of 225 soil samples from 65 locations throughout the reservoir. Results of the analytical test data do not indicate the presence of any constituent that may be an environmental hazard. Fugro's report concludes that the sediments in the reservoir do not pose a threat to the groundwater and can be disposed of at an inert landfill.

## **MORRIS DAM TRANSFER**

On November 7, 1995, the Los Angeles County Board of Supervisors approved an agreement with the Metropolitan Water District that transferred ownership of Morris Dam and Reservoir to the Department of Public Works. The transfer of this facility enables the Department to optimize the operations of the three San Gabriel Canyon Reservoirs for increased flood control, debris control, and water conservation. This should result in the conservation of an additional 7,240 acre-feet of water per year that would have otherwise been wasted to the ocean.



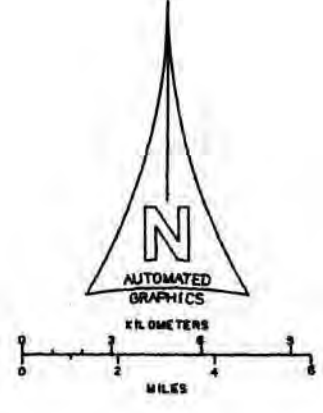
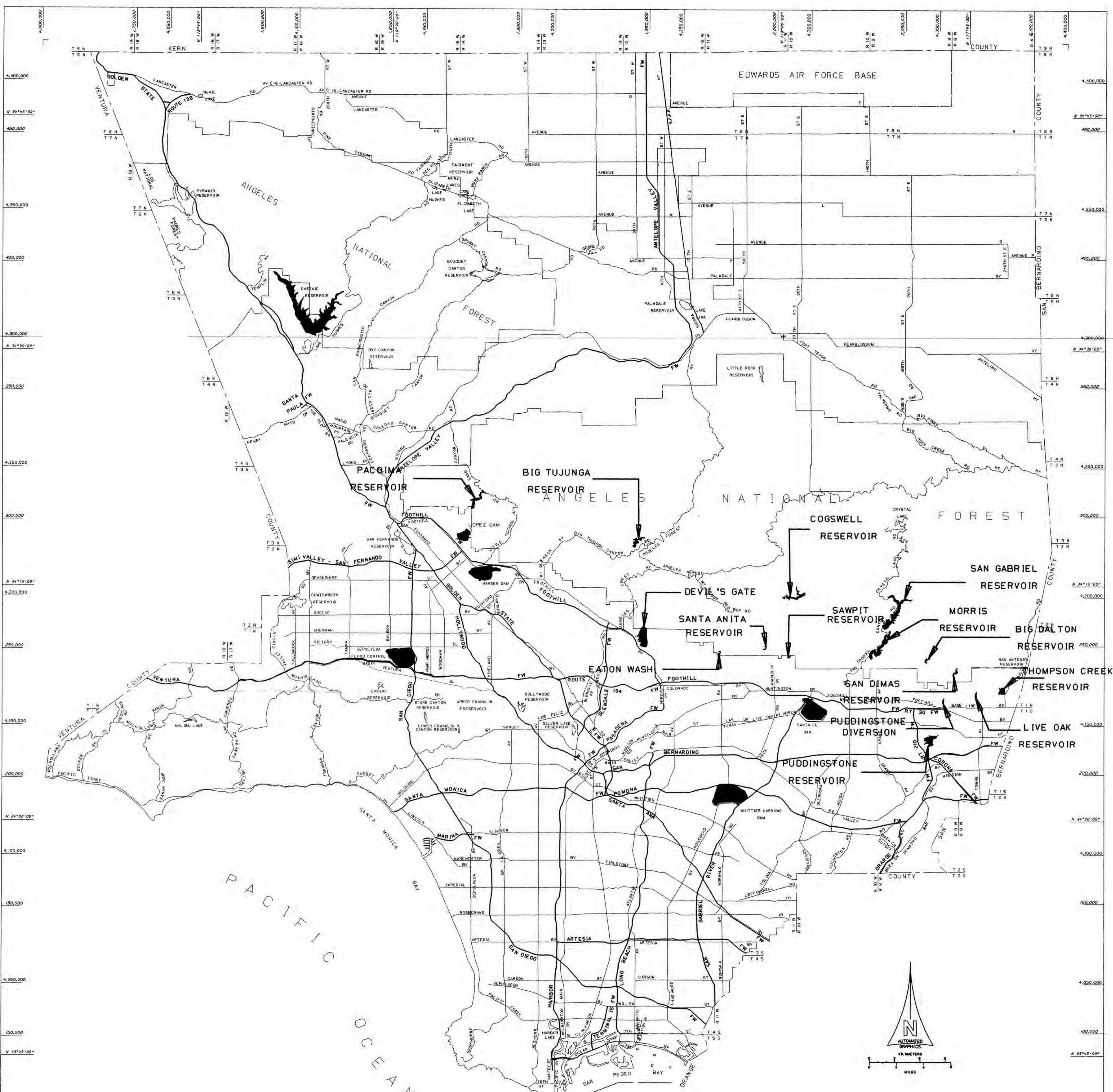

MAP OF  
**COUNTY OF LOS ANGELES**  
 DEPARTMENT OF PUBLIC WORKS  
**RESERVOIR LOCATIONS**  
 1995

# BIG DALTON DAM AND RESERVOIR

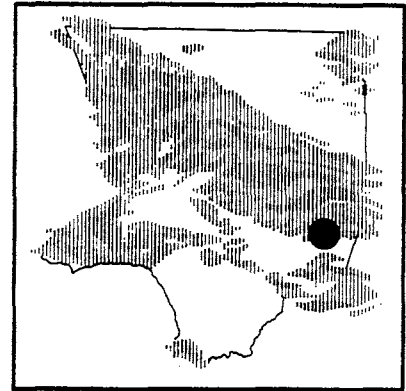
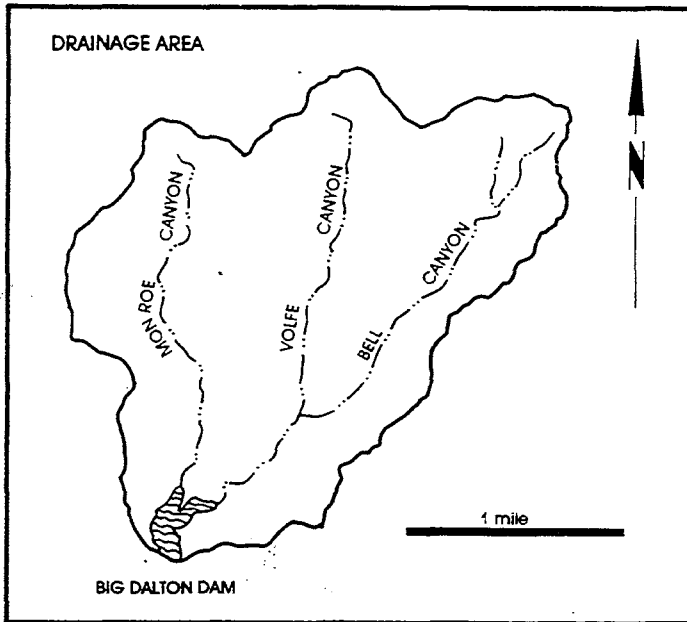

**PURPOSE** - Flood Control and Conservation.  
**DATE CONSTRUCTED** - Started December 1927. Completed August 1929.  
**LOCATION** - Big Dalton Canyon, 4.0 miles northeast of Glendora.  
**DRAINAGE AREA** - 4.5 square miles.  
**CAPACITY** - 963 acre - feet.  
**SPILLWAY ELEVATION** - 1,706.0 feet.

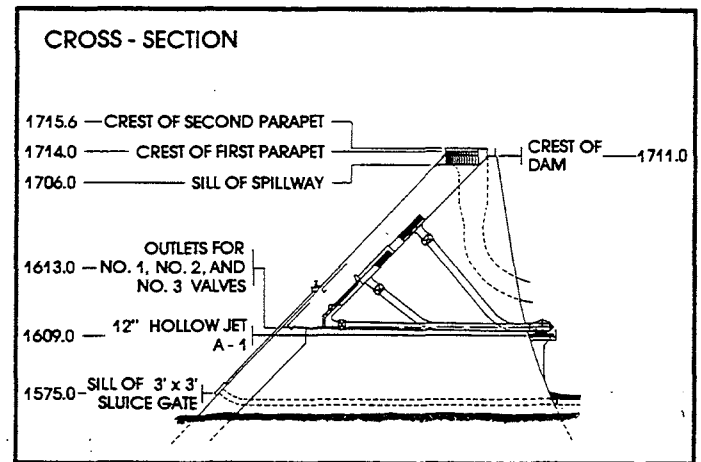

## DAM OPERATION RECORD SUMMARY

(for Water Year 94-95)

Max. Peak Inflow	126.60 CFS from 1400 on 01-10-95 to 1500 on 01-10-95
Max. Peak Outflow	146.00 CFS from 1030 on 02-23-95 to 1045 on 02-23-95
Max. Water Surface Elev.	1,681.00 feet on 03-15-95 STORAGE 462.30 Acre-feet
Min. Water Surface Elev.	1,632.10 feet on 07-20-95 STORAGE 60.90 Acre-feet

(for Water Year 95-96)

Max. Peak Inflow	95.68 CFS from 1600 on 02-20-96 to 1700 on 02-20-96
Max. Peak Outflow	70.60 CFS from 1330 on 02-22-96 to 1345 on 02-22-96
Max. Water Surface Elev.	1,663.50 feet on 02-22-96 STORAGE 251.70 Acre-feet
Min. Water Surface Elev.	1,627.90 feet on 05-16-96 STORAGE 49.50 Acre-feet



**BIG DALTON DAM OPERATION RECORD SUMMARY**  
**WATER YEAR 1994-1995**

	OCTOBER	NOVEMBER	DECEMBER	JANUARY
TOTAL MONTHLY INFLOW (AF)	2.70	4.00	2.40	653.70
TOTAL MONTHLY OUTFLOW (AF)	0.00	0.00	0.00	546.00
MAX. MEAN DAILY INFLOW (CFS)	0.30	0.60	0.20	64.60
TOTAL MONTHLY LOSSES (AF)	1.40	2.80	0.30	0.50
MIN. MEAN DAILY INFLOW (CFS)	0.00	0.00	0.00	0.00
MONTHLY STORAGE CHANGE	1.30	1.20	2.10	107.20

	FEBRUARY	MARCH	APRIL	MAY
TOTAL MONTHLY INFLOW (AF)	613.20	1,690.30	464.40	171.80
TOTAL MONTHLY OUTFLOW (AF)	674.60	1,594.70	593.10	165.20
MAX. MEAN DAILY INFLOW (CFS)	54.90	73.40	14.60	4.60
TOTAL MONTHLY LOSSES (AF)	0.80	1.30	1.70	1.20
MIN. MEAN DAILY INFLOW (CFS)	2.80	9.10	3.90	1.40
MONTHLY STORAGE CHANGE	-62.20	94.30	-130.40	5.40

	JUNE	JULY	AUGUST	SEPTEMBER
TOTAL MONTHLY INFLOW (AF)	142.00	59.00	21.80	14.00
TOTAL MONTHLY OUTFLOW (AF)	152.70	64.90	0.00	28.40
MAX. MEAN DAILY INFLOW (CFS)	3.70	2.30	0.50	0.40
TOTAL MONTHLY LOSSES (AF)	1.90	3.10	3.40	2.50
MIN. MEAN DAILY INFLOW (CFS)	1.00	0.40	0.10	0.00
MONTHLY STORAGE CHANGE	-12.60	-9.00	18.40	-16.90



## BIG DALTON DAM OPERATION RECORD SUMMARY

### WATER YEAR 1995-1996

	OCTOBER	NOVEMBER	DECEMBER	JANUARY
TOTAL MONTHLY INFLOW (AF)	8.70	10.80	22.00	32.50
TOTAL MONTHLY OUTFLOW (AF)	0.00	0.00	45.20	1.20
MAX. MEAN DAILY INFLOW (CFS)	0.30	0.70	1.30	8.20
TOTAL MONTHLY LOSSES (AF)	1.50	2.80	0.70	0.70
MIN. MEAN DAILY INFLOW (CFS)	0.00	0.10	0.00	0.20
MONTHLY STORAGE CHANGE	7.20	8.00	-23.90	30.60

	FEBRUARY	MARCH	APRIL	MAY
TOTAL MONTHLY INFLOW (AF)	401.00	362.60	164.30	181.80
TOTAL MONTHLY OUTFLOW (AF)	357.40	415.90	182.50	169.80
MAX. MEAN DAILY INFLOW (CFS)	53.50	14.60	3.60	4.10
TOTAL MONTHLY LOSSES (AF)	0.50	1.00	1.60	1.40
MIN. MEAN DAILY INFLOW (CFS)	0.20	2.20	1.70	2.10
MONTHLY STORAGE CHANGE	43.10	-54.30	-19.80	10.60

	JUNE	JULY	AUGUST	SEPTEMBER
TOTAL MONTHLY INFLOW (AF)	30.60	19.10	8.40	4.90
TOTAL MONTHLY OUTFLOW (AF)	38.70	4.00	0.00	0.00
MAX. MEAN DAILY INFLOW (CFS)	0.80	0.60	0.20	0.20
TOTAL MONTHLY LOSSES (AF)	2.20	3.00	3.10	2.00
MIN. MEAN DAILY INFLOW (CFS)	0.20	0.10	0.10	0.00
MONTHLY STORAGE CHANGE	-10.30	12.10	5.30	2.90

# BIG TUJUNGA DAM AND RESERVOIR

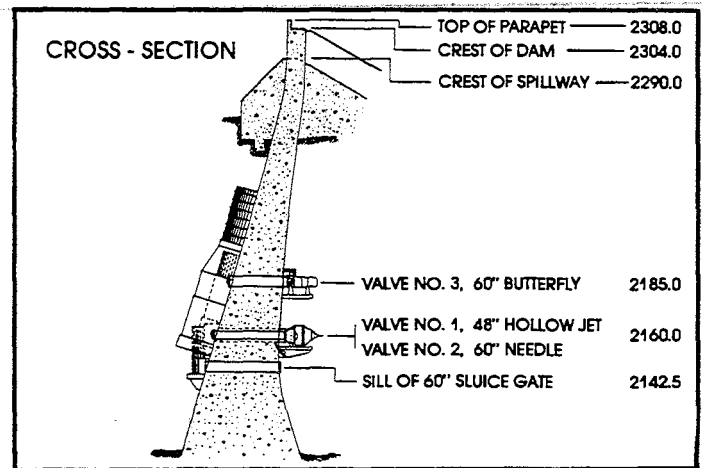
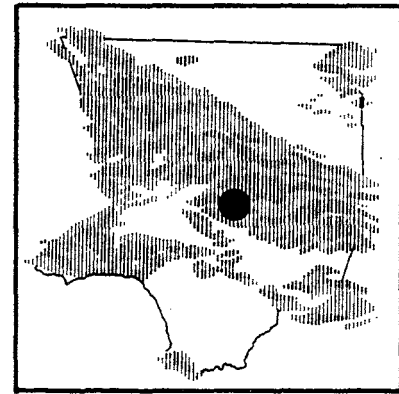
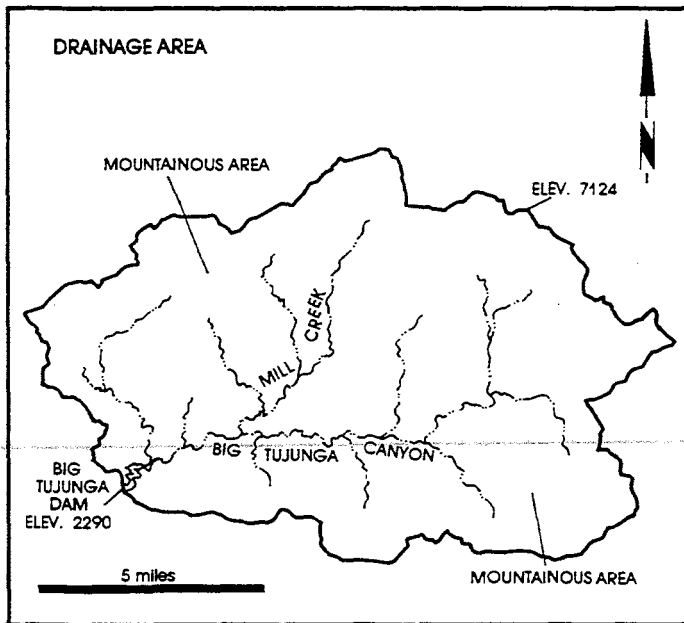

**PURPOSE** - Flood Control Conservation.  
**DATE CONSTRUCTED** - Started January 1930. Completed July 1931.  
**LOCATION** - Big Tujunga Canyon, 10.0 miles northeast of Sunland.  
**DRAINAGE AREA** - 82.3 square miles.  
**CAPACITY** - 6,027 acre - feet.  
**SPILLWAY ELEVATION** - 2,290.0 feet.

## DAM OPERATION RECORD SUMMARY

(for Water Year 94-95)

Max Peak Inflow	3607.50 CFS from 1900 on 01-10-95 to 2000 on 01-10-95
Max Peak Outflow	545.00 CFS from 1445 on 03-12-95 to 1500 on 03-12-95
Max Water Surface Elev	2,241.80 feet on 03-12-95 STORAGE 2,439.10 Acre-feet
Min Water Surface Elev	2,140.00 feet on varies STORAGE 0.20 Acre-feet

† - Values estimated due to incomplete records.

(for Water Year 95-96)

Max Peak Inflow	530.27 CFS from 0900 on 02-21-96 to 1000 on 02-21-96
Max Peak Outflow	455.00 CFS from 0745 on 02-21-96 to 0800 on 02-21-96
Max Water Surface Elev	2,217.00 feet on 02-21-96 STORAGE 1,420.60 Acre-feet
Min Water Surface Elev	2,141.00 feet on varies STORAGE 0.20 Acre-feet

**BIG TUJUNGA DAM OPERATION RECORD SUMMARY<sup>†</sup>**  
**WATER YEAR 1994-1995**

	OCTOBER	NOVEMBER	DECEMBER	JANUARY
TOTAL MONTHLY INFLOW (AF)	116.80	108.90	100.80	10,091.30
TOTAL MONTHLY OUTFLOW (AF)	116.80	108.90	100.40	8,629.30
MAX. MEAN DAILY INFLOW (CFS)	9.60	5.20	2.80	984.70
TOTAL MONTHLY LOSSES (AF)	0.00	0.00	0.00	2.10
MIN. MEAN DAILY INFLOW (CFS)	0.80	1.40	0.20	1.80
MONTHLY STORAGE CHANGE	0.00	0.00	0.40	1,459.90

	FEBRUARY	MARCH	APRIL	MAY
TOTAL MONTHLY INFLOW (AF)	3,969.10	12,470.00	3,611.10	1,607.50
TOTAL MONTHLY OUTFLOW (AF)	4,428.50	12,454.00	4,074.00	2,127.30
MAX. MEAN DAILY INFLOW (CFS)	300.30	1,005.20	109.60	29.10
TOTAL MONTHLY LOSSES (AF)	7.50	9.70	10.80	0.70
MIN. MEAN DAILY INFLOW (CFS)	9.90	2.70	8.90	7.10
MONTHLY STORAGE CHANGE	-466.90	6.30	-473.70	-520.50

	JUNE	JULY	AUGUST	SEPTEMBER
TOTAL MONTHLY INFLOW (AF)	1,644.90	443.20	214.70	184.10
TOTAL MONTHLY OUTFLOW (AF)	1,648.70	444.10	215.20	184.50
MAX. MEAN DAILY INFLOW (CFS)	34.60	9.90	3.50	3.10
TOTAL MONTHLY LOSSES (AF)	0.00	0.00	0.00	0.00
MIN. MEAN DAILY INFLOW (CFS)	9.90	5.00	3.20	2.90
MONTHLY STORAGE CHANGE	-3.80	-0.90	-0.50	-0.40

**BIG TUJUNGA DAM OPERATION RECORD SUMMARY**  
**WATER YEAR 1995-1996**

	OCTOBER	NOVEMBER	DECEMBER	JANUARY
TOTAL MONTHLY INFLOW (AF)	190.60	208.30	240.20	121.90
TOTAL MONTHLY OUTFLOW (AF)	190.60	208.30	239.80	121.40
MAX. MEAN DAILY INFLOW (CFS)	3.10	3.50	4.10	5.90
TOTAL MONTHLY LOSSES (AF)	0.00	0.00	0.00	0.00
MIN. MEAN DAILY INFLOW (CFS)	3.10	3.50	3.90	1.80
MONTHLY STORAGE CHANGE	0.00	0.00	0.40	0.50

	FEBRUARY	MARCH	APRIL	MAY
TOTAL MONTHLY INFLOW (AF)	3,216.10	2,325.90	975.40	539.50
TOTAL MONTHLY OUTFLOW (AF)	2,104.50	2,327.20	982.80	912.20
MAX. MEAN DAILY INFLOW (CFS)	476.70	66.00	24.50	10.70
TOTAL MONTHLY LOSSES (AF)	3.90	10.40	14.40	1.60
MIN. MEAN DAILY INFLOW (CFS)	4.00	22.70	11.00	5.30
MONTHLY STORAGE CHANGE	1,107.70	-11.70	-21.80	-374.30

	JUNE	JULY	AUGUST	SEPTEMBER
TOTAL MONTHLY INFLOW (AF)	300.10	184.40	100.70	87.40
TOTAL MONTHLY OUTFLOW (AF)	337.00	271.30	178.30	97.00
MAX. MEAN DAILY INFLOW (CFS)	7.60	3.90	2.20	2.20
TOTAL MONTHLY LOSSES (AF)	23.60	27.30	24.20	16.50
MIN. MEAN DAILY INFLOW (CFS)	3.70	1.50	1.20	1.10
MONTHLY STORAGE CHANGE	-60.50	-114.20	-101.80	-26.10

# COGSWELL DAM AND RESERVOIR

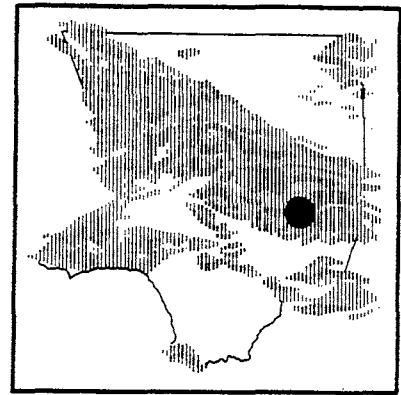
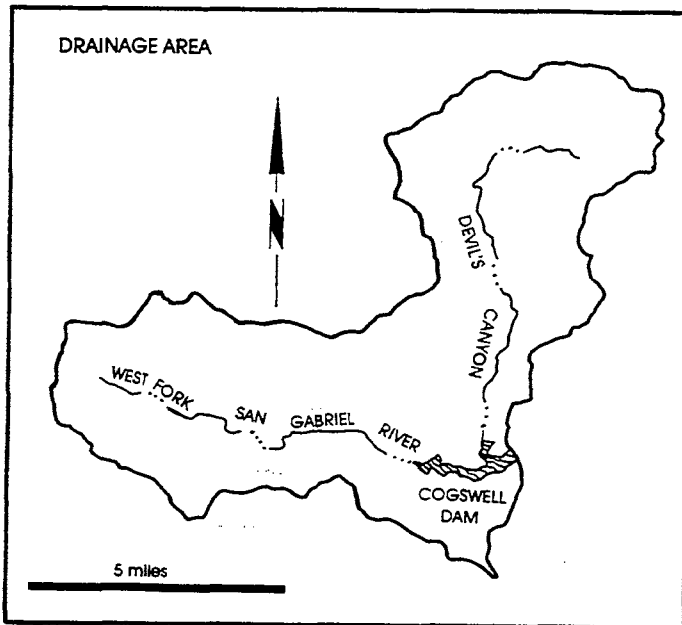

PURPOSE - Flood Control, Conservation, and Recreation.  
 DATE CONSTRUCTED - Started March 1932. Completed April 1934.  
 LOCATION - 22.0 miles north of Azusa.  
 DRAINAGE AREA - 39.2 square miles.  
 CAPACITY - 9,339 acre-feet.  
 SPILLWAY ELEVATION - 2,385.0 feet.

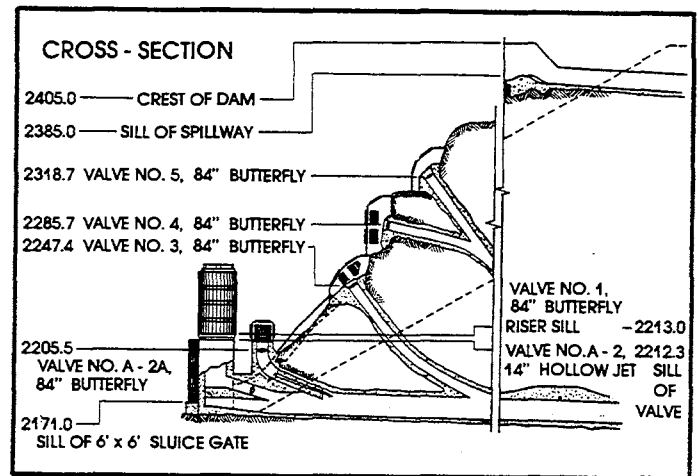

## DAM OPERATION RECORD SUMMARY

(for Water Year 94-95)

Max. Peak Inflow	2478.56 CFS from 1500 on 01-10-95 to 1600 on 01-10-95
Max. Peak Outflow	1740.00 CFS from 1800 on 01-10-95 to 1815 on 01-10-95
Max. Water Surface Elev.	2,277.00 feet on 03-11-95 STORAGE 677.80 Acre-feet
Min. Water Surface Elev.	2,216.60 feet on 12-09-94 STORAGE 7.90 Acre-feet

(for Water Year 95-96)

Max. Peak Inflow	1056.29 CFS from 1800 on 02-20-96 to 1900 on 02-20-96
Max. Peak Outflow	938.00 CFS from 1145 on 02-21-96 to 1200 on 02-21-96
Max. Water Surface Elev.	2,270.56 feet on 02-21-96 STORAGE 538.70 Acre-feet
Min. Water Surface Elev.	2,207.10 feet on varies STORAGE 0.00 Acre-feet



**COGSWELL DAM OPERATION RECORD SUMMARY**  
**WATER YEAR 1994-1995**

	OCTOBER	NOVEMBER	DECEMBER	JANUARY
TOTAL MONTHLY INFLOW (AF)	35.50	48.70	127.60	13,074.00
TOTAL MONTHLY OUTFLOW (AF)	59.90	65.30	56.70	12,781.50
MAX. MEAN DAILY INFLOW (CFS)	1.10	1.30	6.30	1,001.80
TOTAL MONTHLY LOSSES (AF)	1.50	0.50	0.30	0.80
MIN. MEAN DAILY INFLOW (CFS)	0.10	0.30	0.60	3.00
MONTHLY STORAGE CHANGE	-25.90	-17.10	70.60	291.70

	FEBRUARY	MARCH	APRIL	MAY
TOTAL MONTHLY INFLOW (AF)	6,171.80	14,071.10	3,799.80	1,912.70
TOTAL MONTHLY OUTFLOW (AF)	6,010.10	14,050.10	4,118.70	2,004.10
MAX. MEAN DAILY INFLOW (CFS)	739.80	949.10	95.10	42.70
TOTAL MONTHLY LOSSES (AF)	1.20	3.00	4.50	1.70
MIN. MEAN DAILY INFLOW (CFS)	34.10	70.50	39.90	11.20
MONTHLY STORAGE CHANGE	160.50	18.00	-323.40	-93.10

	JUNE	JULY	AUGUST	SEPTEMBER
TOTAL MONTHLY INFLOW (AF)	1,070.60	487.30	207.00	49.90
TOTAL MONTHLY OUTFLOW (AF)	1,081.60	479.40	217.40	146.80
MAX. MEAN DAILY INFLOW (CFS)	29.10	13.00	5.40	3.10
TOTAL MONTHLY LOSSES (AF)	4.20	5.80	6.10	4.30
MIN. MEAN DAILY INFLOW (CFS)	10.00	4.50	1.70	0.00
MONTHLY STORAGE CHANGE	-15.20	2.10	-16.50	-101.20

**COGSWELL DAM OPERATION RECORD SUMMARY**  
**WATER YEAR 1995-1996**

	OCTOBER	NOVEMBER	DECEMBER	JANUARY
TOTAL MONTHLY INFLOW (AF)	197.60	144.30	392.10	621.30
TOTAL MONTHLY OUTFLOW (AF)	194.20	143.40	391.90	620.80
MAX. MEAN DAILY INFLOW (CFS)	5.90	2.80	10.30	58.70
TOTAL MONTHLY LOSSES (AF)	0.10	0.20	0.20	0.10
MIN. MEAN DAILY INFLOW (CFS)	0.80	2.00	2.90	7.70
MONTHLY STORAGE CHANGE	3.30	0.70	0.00	0.40

	FEBRUARY	MARCH	APRIL	MAY
TOTAL MONTHLY INFLOW (AF)	3,362.20	2,615.00	808.60	385.30
TOTAL MONTHLY OUTFLOW (AF)	2,910.50	3,058.50	815.80	388.00
MAX. MEAN DAILY INFLOW (CFS)	495.70	84.90	23.80	8.90
TOTAL MONTHLY LOSSES (AF)	0.90	1.40	0.20	0.00
MIN. MEAN DAILY INFLOW (CFS)	4.70	23.60	8.90	3.90
MONTHLY STORAGE CHANGE	450.80	-444.90	-7.40	-2.70

	JUNE	JULY	AUGUST	SEPTEMBER
TOTAL MONTHLY INFLOW (AF)	174.00	32.30	31.40	15.90
TOTAL MONTHLY OUTFLOW (AF)	174.00	32.30	31.40	15.90
MAX. MEAN DAILY INFLOW (CFS)	5.30	1.50	1.00	0.40
TOTAL MONTHLY LOSSES (AF)	0.00	0.00	0.00	0.00
MIN. MEAN DAILY INFLOW (CFS)	1.70	0.10	0.20	0.20
MONTHLY STORAGE CHANGE	0.00	0.00	0.00	0.00

# DEVIL'S GATE DAM AND RESERVOIR

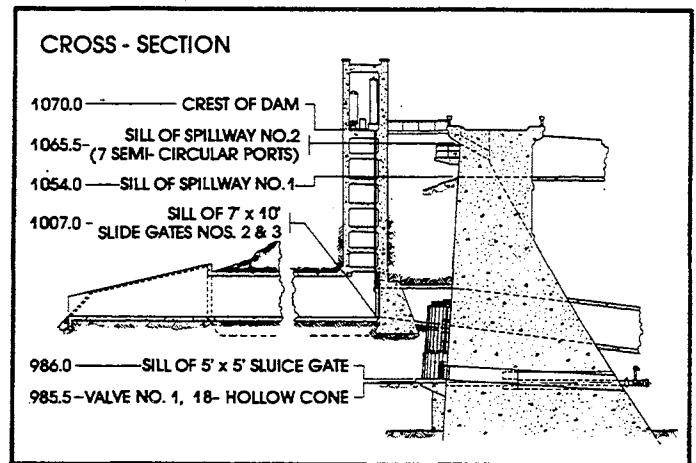
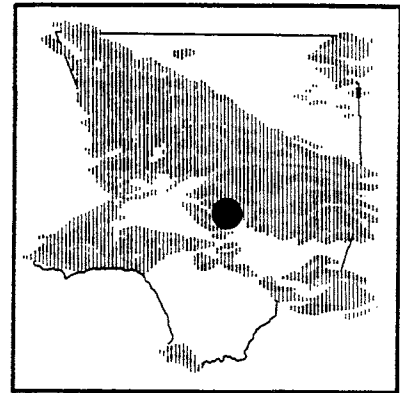
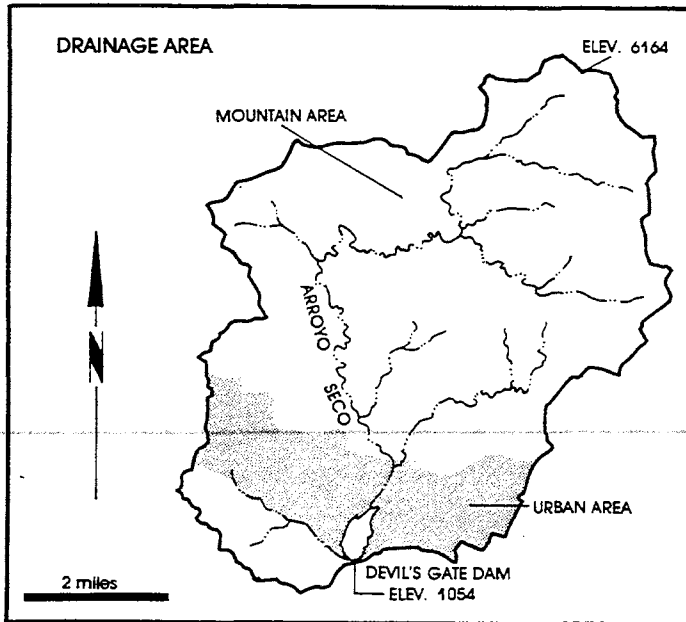

PURPOSE - Flood Control and Conservation.  
 DATE CONSTRUCTED - Started May 1919. Completed June 1920.  
 LOCATION - On Aroyo Seco, northwest of Pasadena.  
 DRAINAGE AREA - 31.9 square miles.  
 CAPACITY - 1,928 acre-feet.  
 SPILLWAY ELEVATION - 1,054.0 feet.

## DAM OPERATION RECORD SUMMARY†

(for Water Year 94-95)

Max. Peak Inflow	2492.50 CFS from 1100 on 01-10-95 to 1200 on 01-10-95		
Max. Peak Outflow	691.00 CFS from 1600 on 02-13-95 to 1630 on 02-13-95		
Max. Water Surface Elev.	1,041.70 feet on 01-11-95	STORAGE	1,483.30 Acre-feet
Min. Water Surface Elev.	989.00 feet on varies	STORAGE	0.00 Acre-feet

† - Values estimated due to incomplete records.

(for Water Year 95-96)

Max. Peak Inflow	584.21 CFS from 1900 on 02-21-96 to 2000 on 02-21-96		
Max. Peak Outflow	477.00 CFS from 1800 on 02-21-96 to 1815 on 02-21-96		
Max. Water Surface Elev.	1,008.50 feet on 02-20-96	STORAGE	20.90 Acre-feet
Min. Water Surface Elev.	989.00 feet on varies	STORAGE	0.00 Acre-feet

† - Values estimated due to incomplete records.

**DEVIL'S GATE DAM OPERATION RECORD SUMMARY<sup>†</sup>**  
**WATER YEAR 1994-1995**

	OCTOBER	NOVEMBER	DECEMBER	JANUARY
TOTAL MONTHLY INFLOW (AF)	47.50	56.60	41.70	7,944.70
TOTAL MONTHLY OUTFLOW (AF)	47.20	56.70	41.30	7,944.60
MAX. MEAN DAILY INFLOW (CFS)	7.90	17.90	4.60	1,030.00
TOTAL MONTHLY LOSSES (AF)	0.00	0.00	0.00	0.00
MIN. MEAN DAILY INFLOW (CFS)	0.10	0.00	0.20	0.20
MONTHLY STORAGE CHANGE	0.30	-0.10	0.40	0.10

	FEBRUARY	MARCH	APRIL	MAY
TOTAL MONTHLY INFLOW (AF)	2,812.50	9,220.30	650.80	121.80
TOTAL MONTHLY OUTFLOW (AF)	2,813.20	9,219.80	650.80	121.80
MAX. MEAN DAILY INFLOW (CFS)	536.20	515.70	31.00	3.00
TOTAL MONTHLY LOSSES (AF)	0.00	0.00	0.00	0.00
MIN. MEAN DAILY INFLOW (CFS)	0.90	10.00	4.80	1.00
MONTHLY STORAGE CHANGE	-0.70	0.50	0.00	0.00

	JUNE	JULY	AUGUST	SEPTEMBER
TOTAL MONTHLY INFLOW (AF)	220.10	26.60	0.80	29.70
TOTAL MONTHLY OUTFLOW (AF)	220.20	26.80	1.00	29.80
MAX. MEAN DAILY INFLOW (CFS)	10.00	0.90	0.10	0.50
TOTAL MONTHLY LOSSES (AF)	0.00	0.00	0.00	0.00
MIN. MEAN DAILY INFLOW (CFS)	3.00	0.10	0.00	0.40
MONTHLY STORAGE CHANGE	-0.10	-0.20	-0.20	-0.10

**DEVIL'S GATE DAM OPERATION RECORD SUMMARY<sup>†</sup>**  
**WATER YEAR 1995-1996**

	OCTOBER	NOVEMBER	DECEMBER	JANUARY
TOTAL MONTHLY INFLOW (AF)	24.60	3.10	18.60	320.30
TOTAL MONTHLY OUTFLOW (AF)	24.60	3.40	18.60	320.30
MAX. MEAN DAILY INFLOW (CFS)	0.40	0.40	4.00	129.00
TOTAL MONTHLY LOSSES (AF)	0.00	0.00	0.00	0.00
MIN. MEAN DAILY INFLOW (CFS)	0.40	0.00	0.00	0.20
MONTHLY STORAGE CHANGE	0.00	-0.30	0.00	0.00

	FEBRUARY	MARCH	APRIL	MAY
TOTAL MONTHLY INFLOW (AF)	2,028.70	377.30	176.00	78.90
TOTAL MONTHLY OUTFLOW (AF)	2,028.70	377.30	176.10	78.90
MAX. MEAN DAILY INFLOW (CFS)	413.70	23.90	4.00	2.00
TOTAL MONTHLY LOSSES (AF)	0.00	0.00	0.00	0.00
MIN. MEAN DAILY INFLOW (CFS)	2.10	3.80	1.60	1.10
MONTHLY STORAGE CHANGE	0.00	0.00	-0.10	0.00

	JUNE	JULY	AUGUST	SEPTEMBER
TOTAL MONTHLY INFLOW (AF)	65.50	14.30	0.00	11.90
TOTAL MONTHLY OUTFLOW (AF)	65.50	14.30	0.00	11.90
MAX. MEAN DAILY INFLOW (CFS)	1.10	2.50	0.00	0.20
TOTAL MONTHLY LOSSES (AF)	0.00	0.00	0.00	0.00
MIN. MEAN DAILY INFLOW (CFS)	1.10	0.00	0.00	0.20
MONTHLY STORAGE CHANGE	0.00	0.00	0.00	0.00



# EATON WASH DAM AND RESERVOIR

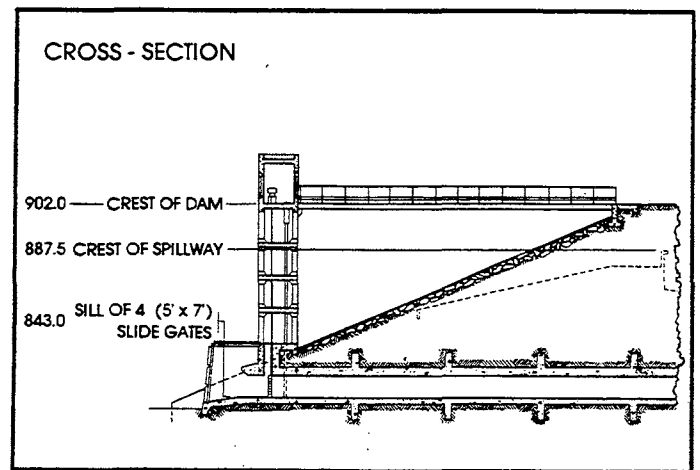
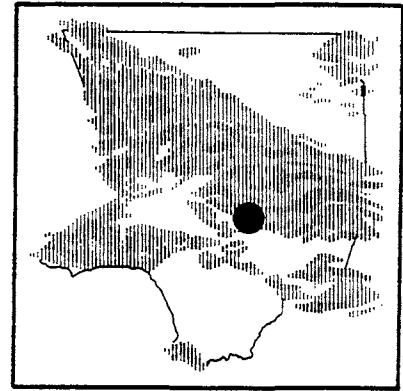
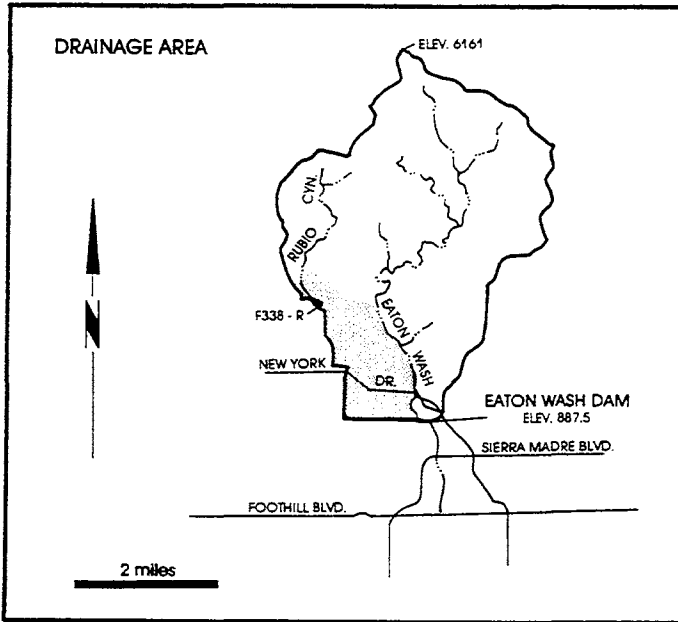

**PURPOSE** - Debris Storage and Conservation.  
**DATE CONSTRUCTED** - Started January 1936. Completed February 1937.  
**LOCATION** - Eaton Wash, northeast of Pasadena.  
**DRAINAGE AREA** - 12.4 square miles.  
**CAPACITY** - 879 acre - feet.  
**SPILLWAY ELEVATION** - 887.5 feet.

## DAM OPERATION RECORD SUMMARY

(for Water Year 94-95)

Max. Peak Inflow	757.49 CFS from 1200 on 01-10-95 to 1300 on 01-10-95
Max. Peak Outflow	429.00 CFS from 1430 on 01-10-95 to 1445 on 01-10-95
Max. Water Surface Elev.	882.50 feet on 01-25-95 STORAGE 605.40 Acre-feet
Min. Water Surface Elev.	842.00 feet on varies STORAGE 0.00 Acre-feet

(for Water Year 95-96)

Max. Peak Inflow	265.80 CFS from 2300 on 02-20-96 to 2400 on 02-20-96
Max. Peak Outflow	298.00 CFS from 2245 on 02-21-96 to 2300 on 02-21-96
Max. Water Surface Elev.	881.20 feet on 02-21-96 STORAGE 561.10 Acre-feet
Min. Water Surface Elev.	842.00 feet on varies STORAGE 0.00 Acre-feet

**EATON WASH DAM OPERATION RECORD SUMMARY**  
**WATER YEAR 1994-1995**

	OCTOBER	NOVEMBER	DECEMBER	JANUARY
TOTAL MONTHLY INFLOW (AF)	3.00	2.40	56.50	2,112.00
TOTAL MONTHLY OUTFLOW (AF)	3.00	2.40	1.20	1,691.70
MAX. MEAN DAILY INFLOW (CFS)	0.30	0.30	6.70	224.70
TOTAL MONTHLY LOSSES (AF)	0.00	0.00	0.00	0.00
MIN. MEAN DAILY INFLOW (CFS)	0.00	0.00	0.00	0.00
MONTHLY STORAGE CHANGE	0.00	0.00	55.30	420.30

	FEBRUARY	MARCH	APRIL	MAY
TOTAL MONTHLY INFLOW (AF)	980.80	2,896.50	768.30	446.00
TOTAL MONTHLY OUTFLOW (AF)	1,015.30	2,838.30	1,080.00	461.20
MAX. MEAN DAILY INFLOW (CFS)	127.50	123.10	21.40	11.40
TOTAL MONTHLY LOSSES (AF)	0.00	0.00	0.00	0.00
MIN. MEAN DAILY INFLOW (CFS)	6.70	5.90	9.00	1.90
MONTHLY STORAGE CHANGE	-34.50	58.20	-311.70	-15.20

	JUNE	JULY	AUGUST	SEPTEMBER
TOTAL MONTHLY INFLOW (AF)	182.70	35.20	16.90	0.00
TOTAL MONTHLY OUTFLOW (AF)	224.50	75.80	68.00	0.00
MAX. MEAN DAILY INFLOW (CFS)	19.30	4.30	2.50	0.00
TOTAL MONTHLY LOSSES (AF)	0.00	0.00	0.00	0.00
MIN. MEAN DAILY INFLOW (CFS)	0.00	0.00	0.00	0.00
MONTHLY STORAGE CHANGE	-41.80	-40.60	-51.10	0.00

**EATON WASH DAM OPERATION RECORD SUMMARY**  
**WATER YEAR 1995-1996**

	OCTOBER	NOVEMBER	DECEMBER	JANUARY
TOTAL MONTHLY INFLOW (AF)	0.00	0.00	0.00	100.70
TOTAL MONTHLY OUTFLOW (AF)	0.00	0.00	0.00	12.70
MAX. MEAN DAILY INFLOW (CFS)	0.00	0.00	0.00	45.70
TOTAL MONTHLY LOSSES (AF)	0.00	0.00	0.00	0.00
MIN. MEAN DAILY INFLOW (CFS)	0.00	0.00	0.00	0.00
MONTHLY STORAGE CHANGE	0.00	0.00	0.00	88.00

	FEBRUARY	MARCH	APRIL	MAY
TOTAL MONTHLY INFLOW (AF)	1,019.60	599.00	161.80	3.80
TOTAL MONTHLY OUTFLOW (AF)	1,007.20	632.30	121.80	84.70
MAX. MEAN DAILY INFLOW (CFS)	157.90	32.40	9.70	0.60
TOTAL MONTHLY LOSSES (AF)	0.00	0.00	0.00	25.80
MIN. MEAN DAILY INFLOW (CFS)	0.00	1.40	0.50	0.00
MONTHLY STORAGE CHANGE	12.40	-33.30	40.00	-106.70

	JUNE	JULY	AUGUST	SEPTEMBER
TOTAL MONTHLY INFLOW (AF)	6.00	0.00	0.00	0.00
TOTAL MONTHLY OUTFLOW (AF)	6.00	0.00	0.00	0.00
MAX. MEAN DAILY INFLOW (CFS)	0.10	0.00	0.00	0.00
TOTAL MONTHLY LOSSES (AF)	0.00	0.00	0.00	0.00
MIN. MEAN DAILY INFLOW (CFS)	0.10	0.00	0.00	0.00
MONTHLY STORAGE CHANGE	0.00	0.00	0.00	0.00

# LIVE OAK DAM AND RESERVOIR

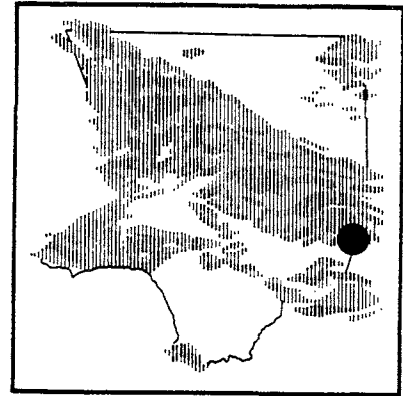
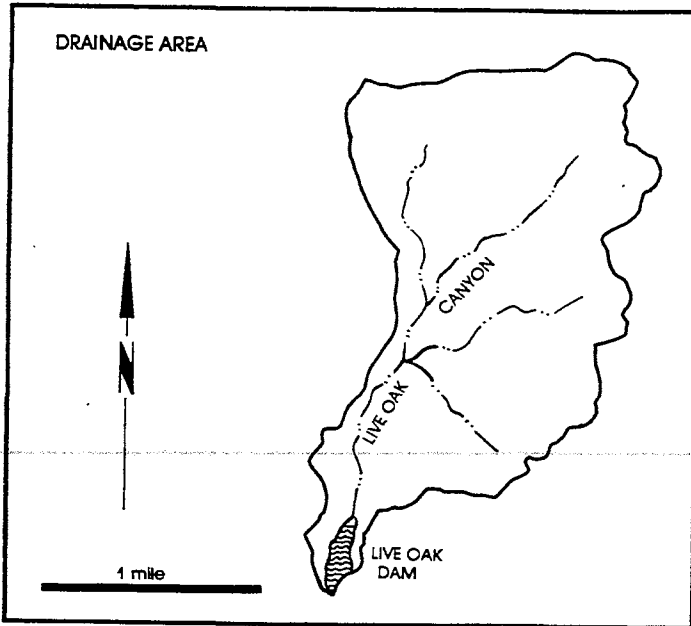

**PURPOSE** - Flood Control and Conservation.  
**DATE CONSTRUCTED** - Started August 1921. Completed November 1922.  
**LOCATION** - 2.5 miles northeast of La Veme.  
**DRAINAGE AREA** - 2.3 square miles.  
**CAPACITY** - 240 acre-feet.  
**SPILLWAY ELEVATION** - 1,496.0 feet.

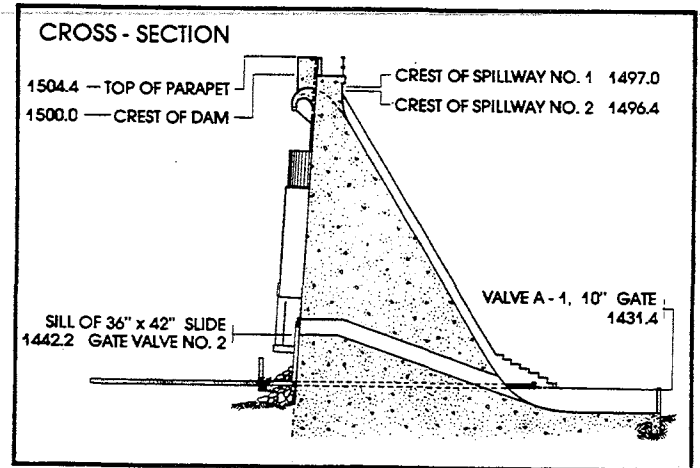

## DAM OPERATION RECORD SUMMARY

(for Water Year 94-95)

Max. Peak Inflow	85.60 CFS from 1500 on 01-10-95 to 1600 on 01-10-95
Max. Peak Outflow	103.00 CFS from 1200 on 03-06-95 to 1215 on 03-06-95
Max. Water Surface Elev.	1,495.85 feet on 04-19-95 STORAGE 230.50 Acre-feet
Min. Water Surface Elev.	1,441.00 feet on varies STORAGE 0.00 Acre-feet

(for Water Year 95-96)

Max. Peak Inflow	75.14 CFS from 1800 on 02-20-96 to 1900 on 02-20-96
Max. Peak Outflow	82.40 CFS from 0915 on 02-21-96 to 0930 on 02-21-96
Max. Water Surface Elev.	1,486.20 feet on 02-21-96 STORAGE 141.80 Acre-feet
Min. Water Surface Elev.	1,443.00 feet on varies STORAGE 0.00 Acre-feet

**LIVE OAK DAM OPERATION RECORD SUMMARY**  
**WATER YEAR 1994-1995**

	OCTOBER	NOVEMBER	DECEMBER	JANUARY
TOTAL MONTHLY INFLOW (AF)	0.00	0.00	6.90	185.00
TOTAL MONTHLY OUTFLOW (AF)	0.00	0.00	6.90	96.20
MAX. MEAN DAILY INFLOW (CFS)	0.00	0.00	0.30	27.20
TOTAL MONTHLY LOSSES (AF)	0.00	0.00	0.00	0.00
MIN. MEAN DAILY INFLOW (CFS)	0.00	0.00	0.00	0.20
MONTHLY STORAGE CHANGE	0.00	0.00	0.00	88.80

	FEBRUARY	MARCH	APRIL	MAY
TOTAL MONTHLY INFLOW (AF)	88.50	334.40	34.30	27.40
TOTAL MONTHLY OUTFLOW (AF)	85.10	228.70	14.90	113.10
MAX. MEAN DAILY INFLOW (CFS)	19.60	32.40	1.30	1.50
TOTAL MONTHLY LOSSES (AF)	0.00	0.00	0.00	0.00
MIN. MEAN DAILY INFLOW (CFS)	0.10	0.50	0.00	0.00
MONTHLY STORAGE CHANGE	3.40	105.70	19.40	-85.70

	JUNE	JULY	AUGUST	SEPTEMBER
TOTAL MONTHLY INFLOW (AF)	123.10	14.00	6.60	0.00
TOTAL MONTHLY OUTFLOW (AF)	253.10	9.10	13.10	0.00
MAX. MEAN DAILY INFLOW (CFS)	3.90	1.40	0.80	0.00
TOTAL MONTHLY LOSSES (AF)	0.00	0.00	0.00	0.00
MIN. MEAN DAILY INFLOW (CFS)	0.20	0.00	0.00	0.00
MONTHLY STORAGE CHANGE	-130.00	4.90	-6.50	0.00



**LIVE OAK DAM OPERATION RECORD SUMMARY**  
**WATER YEAR 1995-1996**

	OCTOBER	NOVEMBER	DECEMBER	JANUARY
TOTAL MONTHLY INFLOW (AF)	0.00	0.00	5.60	21.20
TOTAL MONTHLY OUTFLOW (AF)	0.00	0.00	2.00	0.20
MAX. MEAN DAILY INFLOW (CFS)	0.00	0.00	0.40	4.00
TOTAL MONTHLY LOSSES (AF)	0.00	0.00	0.00	0.00
MIN. MEAN DAILY INFLOW (CFS)	0.00	0.00	0.00	0.10
MONTHLY STORAGE CHANGE	0.00	0.00	3.60	21.00

	FEBRUARY	MARCH	APRIL	MAY
TOTAL MONTHLY INFLOW (AF)	176.70	92.80	32.60	20.80
TOTAL MONTHLY OUTFLOW (AF)	120.00	174.10	9.30	43.60
MAX. MEAN DAILY INFLOW (CFS)	36.50	3.70	1.40	0.60
TOTAL MONTHLY LOSSES (AF)	0.00	0.00	0.00	0.00
MIN. MEAN DAILY INFLOW (CFS)	0.20	0.30	0.20	0.00
MONTHLY STORAGE CHANGE	56.70	-81.30	23.30	-22.80

	JUNE	JULY	AUGUST	SEPTEMBER
TOTAL MONTHLY INFLOW (AF)	7.60	0.00	0.00	0.00
TOTAL MONTHLY OUTFLOW (AF)	7.50	0.00	0.00	0.00
MAX. MEAN DAILY INFLOW (CFS)	0.60	0.00	0.00	0.00
TOTAL MONTHLY LOSSES (AF)	0.00	0.00	0.00	0.00
MIN. MEAN DAILY INFLOW (CFS)	0.10	0.00	0.00	0.00
MONTHLY STORAGE CHANGE	0.10	0.00	0.00	0.00

# MORRIS DAM AND RESERVOIR

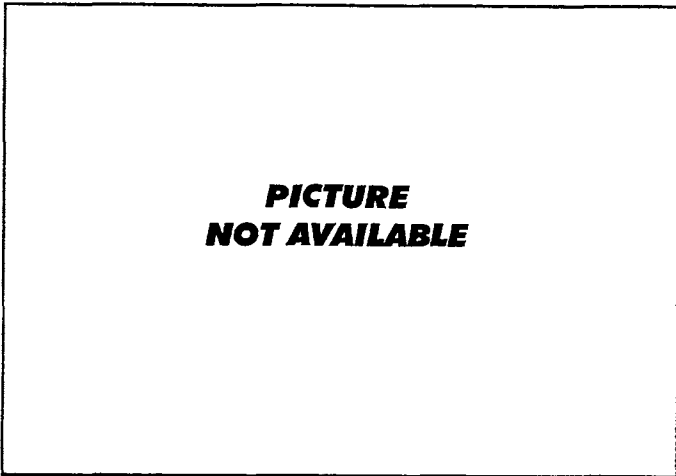
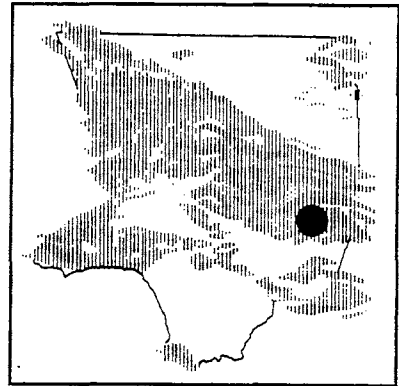
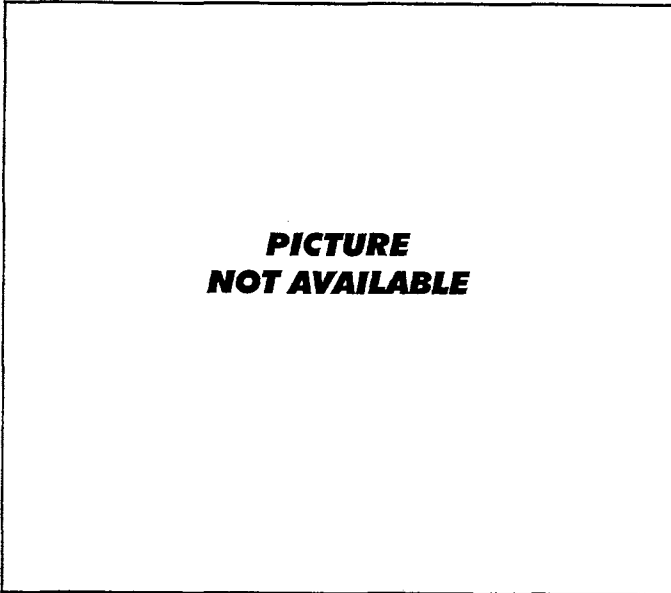

**PURPOSE** - Water Conservation  
**DATE CONSTRUCTED** - Started April 1932. Completed 1935.  
**LOCATION** - San Gabriel Canyon, 5 miles north of Azusa.  
**DRAINAGE AREA** - 14.3 square miles (uncontrolled).  
                           202.7 square miles controlled by  
                           San Gabriel and Cogswell dams.  
                           Total 217 square miles.  
**CAPACITY** - 21,800 acre feet.  
**SPILLWAY ELEVATION** - 1,152 feet.

## DAM OPERATION RECORD SUMMARY

(for Water Year 94-95)

Max. Peak Inflow	3130.69 CFS from 1800 on 01-10-95 to 1900 on 01-10-95
Max. Peak Outflow	2880.00 CFS from 0545 on 02-16-95 to 0600 on 02-16-95
Max. Water Surface Elev.	1,169.70 feet on 01-18-95 STORAGE 27,929.10 Acre-feet
Min. Water Surface Elev.	1,130.72 feet on 08-03-95 STORAGE 15,570.10 Acre-feet

(for Water Year 95-96)

Max. Peak Inflow	372.17 CFS from 0300 on 02-20-96 to 0400 on 02-20-96
Max. Peak Outflow	1,080.00 CFS from 1400 on 10-06-95 to 1415 on 10-06-95
Max. Water Surface Elev.	1,167.05 feet on 08-20-96 STORAGE 26,960.80 Acre-feet
Min. Water Surface Elev.	1,126.99 feet on 10-16-95 STORAGE 14,596.60 Acre-feet

**MORRIS DAM OPERATION RECORD SUMMARY**  
**WATER YEAR 1994-1995**

	OCTOBER	NOVEMBER	DECEMBER	JANUARY
TOTAL MONTHLY INFLOW (AF)	398.00	459.40	391.80	24,803.70
TOTAL MONTHLY OUTFLOW (AF)	55.90	1,422.70	5,312.30	19,295.60
MAX. MEAN DAILY INFLOW (CFS)	24.70	48.30	14.20	2,346.80
TOTAL MONTHLY LOSSES (AF)	185.80	113.80	78.00	64.70
MIN. MEAN DAILY INFLOW (CFS)	3.60	1.30	2.30	2.50
MONTHLY STORAGE CHANGE	156.30	-1,077.10	-4,998.50	5,443.40

	FEBRUARY	MARCH	APRIL	MAY
TOTAL MONTHLY INFLOW (AF)	32,274.40	65,186.50	29,736.70	12,480.70
TOTAL MONTHLY OUTFLOW (AF)	36,525.60	54,960.00	29,720.30	20,966.90
MAX. MEAN DAILY INFLOW (CFS)	2,771.20	3,858.40	674.30	330.70
TOTAL MONTHLY LOSSES (AF)	100.90	142.90	186.40	127.90
MIN. MEAN DAILY INFLOW (CFS)	152.90	253.20	408.20	92.90
MONTHLY STORAGE CHANGE	-4,352.10	10,083.60	-170.00	-8,614.10

	JUNE	JULY	AUGUST	SEPTEMBER
TOTAL MONTHLY INFLOW (AF)	14,152.20	15,371.90	8,937.80	2,942.50
TOTAL MONTHLY OUTFLOW (AF)	11,262.90	18,522.00	3,287.80	384.00
MAX. MEAN DAILY INFLOW (CFS)	282.50	333.80	271.80	199.70
TOTAL MONTHLY LOSSES (AF)	206.30	318.90	310.60	302.50
MIN. MEAN DAILY INFLOW (CFS)	135.30	190.20	17.00	14.80
MONTHLY STORAGE CHANGE	2,683.00	-3,469.00	5,339.40	2,256.00

## MORRIS DAM OPERATION RECORD SUMMARY

### WATER YEAR 1995-1996

	OCTOBER	NOVEMBER	DECEMBER	JANUARY
TOTAL MONTHLY INFLOW (AF)	1,018.60	1,188.90	580.00	707.70
TOTAL MONTHLY OUTFLOW (AF)	10,965.00	82.90	91.60	73.80
MAX. MEAN DAILY INFLOW (CFS)	48.60	57.40	18.70	103.40
TOTAL MONTHLY LOSSES (AF)	15.50	9.50	9.00	6.90
MIN. MEAN DAILY INFLOW (CFS)	1.30	5.40	4.20	5.20
MONTHLY STORAGE CHANGE	-9,961.90	1,096.50	479.40	627.00

	FEBRUARY	MARCH	APRIL	MAY
TOTAL MONTHLY INFLOW (AF)	1,600.80	4,550.30	8,327.90	1,076.80
TOTAL MONTHLY OUTFLOW (AF)	249.90	4,837.70	2,971.80	184.50
MAX. MEAN DAILY INFLOW (CFS)	208.20	454.20	304.50	110.50
TOTAL MONTHLY LOSSES (AF)	5.90	15.20	15.80	20.40
MIN. MEAN DAILY INFLOW (CFS)	6.70	12.40	5.40	6.80
MONTHLY STORAGE CHANGE	1,345.00	-302.60	5,340.30	871.90

	JUNE	JULY	AUGUST	SEPTEMBER
TOTAL MONTHLY INFLOW (AF)	7,307.50	6,862.90	5,461.60	3,214.90
TOTAL MONTHLY OUTFLOW (AF)	15,453.40	85.30	3,386.80	8,859.60
MAX. MEAN DAILY INFLOW (CFS)	282.10	196.80	201.70	201.80
TOTAL MONTHLY LOSSES (AF)	21.50	25.40	29.20	19.90
MIN. MEAN DAILY INFLOW (CFS)	2.30	13.30	2.40	2.20
MONTHLY STORAGE CHANGE	-8,167.40	6,752.20	2,045.60	-5,664.60

# PACOIMA DAM AND RESERVOIR

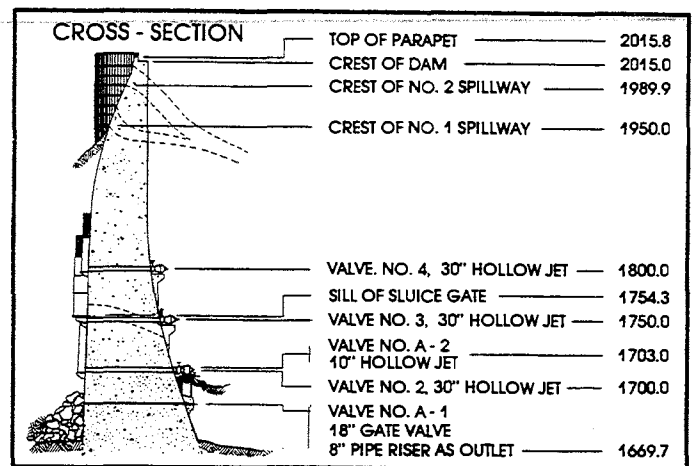
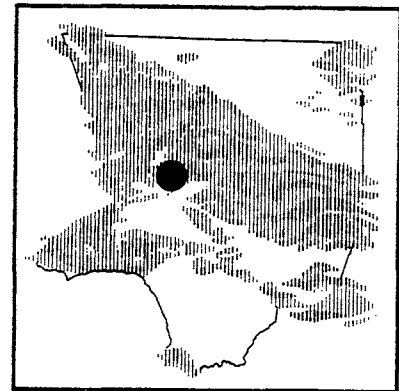
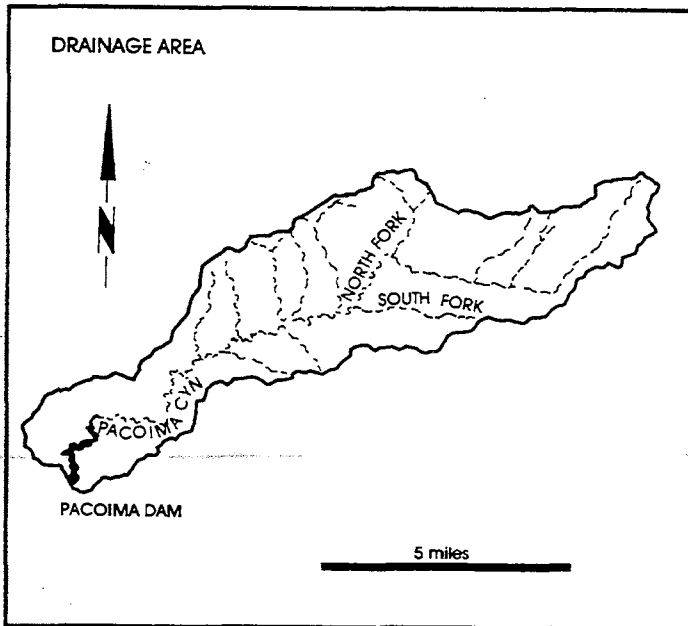

**PURPOSE** - Flood Control and Conservation.  
**DATE CONSTRUCTED** - Started March 1925. Completed February 1929.  
**LOCATION** - Pacoima Canyon, 4.0 miles northeast of San Fernando.  
**DRAINAGE AREA** - 28.2 square miles.  
**CAPACITY** - 3,929 acre - feet.  
**SPILLWAY ELEVATION** - 1,950.0 feet.

## DAM OPERATION RECORD SUMMARY†

(for Water Year 94-95)

Max. Peak Inflow	1072.94 CFS from 1300 on 01-10-95 to 1400 on 01-10-95
Max. Peak Outflow	700.00 CFS from 1700 on 01-10-95 to 1715 on 01-10-95
Max. Water Surface Elev.	1,889.90 feet on 03-20-95 STORAGE 1,186.00 Acre-feet
Min. Water Surface Elev.	1,819.00 feet on 09-07-95 STORAGE 120.70 Acre-feet

(for Water Year 95-96)

Max. Peak Inflow	532.35 CFS from 0100 on 02-21-96 to 0200 on 02-21-96
Max. Peak Outflow	505.00 CFS from 0700 on 02-21-96 to 1415 on 02-21-96
Max. Water Surface Elev.	1,881.00 feet on 02-21-96 STORAGE 991.10 Acre-feet
Min. Water Surface Elev.	1,812.70 feet on varies STORAGE 83.60 Acre-feet



**PACOIMA DAM OPERATION RECORD SUMMARY**  
**WATER YEAR 1994-1995**

	OCTOBER	NOVEMBER	DECEMBER	JANUARY
TOTAL MONTHLY INFLOW (AF)	45.80	34.60	46.80	4,665.30
TOTAL MONTHLY OUTFLOW (AF)	0.00	1.80	0.00	4,306.50
MAX. MEAN DAILY INFLOW (CFS)	2.00	1.40	2.00	307.90
TOTAL MONTHLY LOSSES (AF)	10.80	8.70	7.20	3.80
MIN. MEAN DAILY INFLOW (CFS)	0.30	0.00	0.20	0.30
MONTHLY STORAGE CHANGE	35.00	24.10	39.60	355.00

	FEBRUARY	MARCH	APRIL	MAY
TOTAL MONTHLY INFLOW (AF)	3,370.50	7,824.00	3,100.30	1,785.90
TOTAL MONTHLY OUTFLOW (AF)	3,346.10	7,705.80	3,752.70	1,644.30
MAX. MEAN DAILY INFLOW (CFS)	161.10	351.40	80.50	43.10
TOTAL MONTHLY LOSSES (AF)	9.00	7.50	17.60	6.20
MIN. MEAN DAILY INFLOW (CFS)	28.60	46.10	17.60	17.40
MONTHLY STORAGE CHANGE	15.40	110.70	-670.00	135.40

	JUNE	JULY	AUGUST	SEPTEMBER
TOTAL MONTHLY INFLOW (AF)	1,504.10	760.10	113.50	295.80
TOTAL MONTHLY OUTFLOW (AF)	1,594.70	831.10	200.30	326.50
MAX. MEAN DAILY INFLOW (CFS)	53.20	20.90	6.20	26.70
TOTAL MONTHLY LOSSES (AF)	8.70	13.20	12.20	6.80
MIN. MEAN DAILY INFLOW (CFS)	10.50	2.60	0.40	0.10
MONTHLY STORAGE CHANGE	-99.30	-84.20	-99.00	-37.50

**PACOIMA DAM OPERATION RECORD SUMMARY**  
**WATER YEAR 1995-1996**

	OCTOBER	NOVEMBER	DECEMBER	JANUARY
TOTAL MONTHLY INFLOW (AF)	67.90	65.70	59.90	87.70
TOTAL MONTHLY OUTFLOW (AF)	0.00	6.50	0.00	0.00
MAX. MEAN DAILY INFLOW (CFS)	2.10	4.10	1.40	12.50
TOTAL MONTHLY LOSSES (AF)	6.20	6.80	5.40	6.40
MIN. MEAN DAILY INFLOW (CFS)	0.40	0.40	0.30	0.80
MONTHLY STORAGE CHANGE	61.70	52.40	54.50	81.30

	FEBRUARY	MARCH	APRIL	MAY
TOTAL MONTHLY INFLOW (AF)	2,167.30	2,607.10	1,243.50	687.70
TOTAL MONTHLY OUTFLOW (AF)	1,864.70	3,038.90	1,459.20	687.70
MAX. MEAN DAILY INFLOW (CFS)	388.70	97.60	32.50	15.00
TOTAL MONTHLY LOSSES (AF)	4.60	6.30	3.00	0.00
MIN. MEAN DAILY INFLOW (CFS)	0.40	20.20	10.10	10.00
MONTHLY STORAGE CHANGE	298.00	-438.10	-218.70	0.00

	JUNE	JULY	AUGUST	SEPTEMBER
TOTAL MONTHLY INFLOW (AF)	295.30	104.00	145.90	122.80
TOTAL MONTHLY OUTFLOW (AF)	292.40	65.90	160.30	134.70
MAX. MEAN DAILY INFLOW (CFS)	10.00	2.80	7.40	6.10
TOTAL MONTHLY LOSSES (AF)	1.70	4.80	6.30	3.80
MIN. MEAN DAILY INFLOW (CFS)	0.00	1.10	0.40	0.40
MONTHLY STORAGE CHANGE	1.20	33.30	-20.70	-15.70

# PUDDINGSTONE DAM AND RESERVOIR

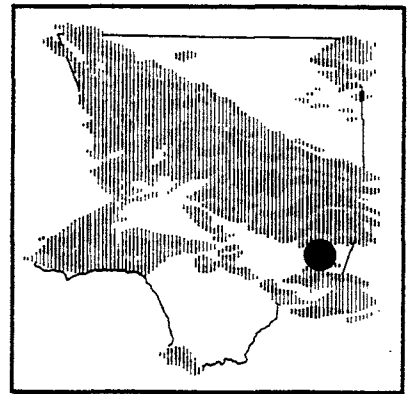
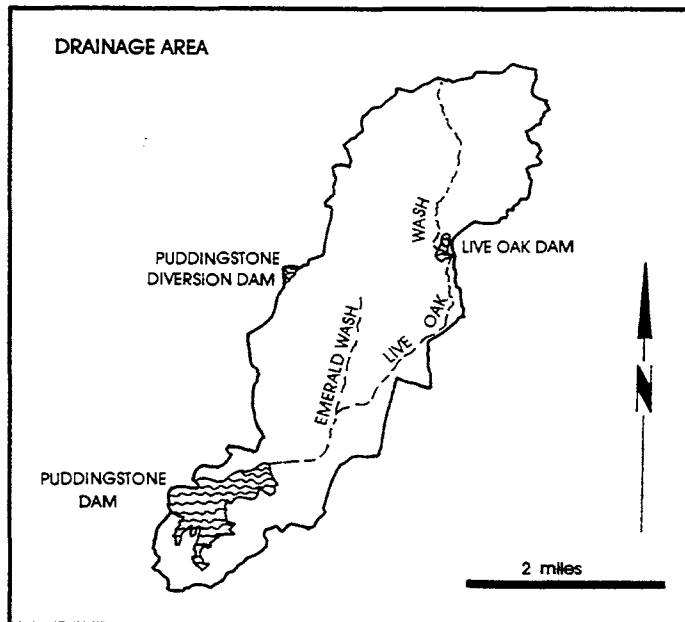

**PURPOSE** - Flood Control and Recreation.  
**DATE CONSTRUCTED** - Started February 1925. Completed January 1928.  
**LOCATION** - 1.0 mile south of San Dimas.  
**DRAINAGE AREA** - 11.0 square miles (uncontrolled)  
                   22.1 square miles (controlled)  
                   Total 33.1 square miles  
**CAPACITY** - 16,856 acre - feet.  
**SPILLWAY ELEVATION** - 970.0 feet.

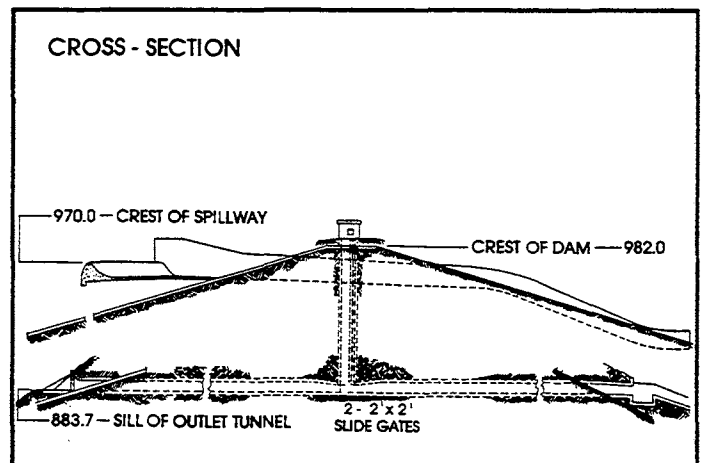

## DAM OPERATION RECORD SUMMARY

(for Water Year 94-95)

Max. Peak Inflow	1411.06 CFS from 1600 on 01-10-95 to 1700 on 01-10-95
Max. Peak Outflow	834.00 CFS from 0545 on 03-06-95 to 0600 on 03-06-95
Max. Water Surface Elev.	945.68 feet on 03-06-95 STORAGE 7,523.30 Acre-feet
Min. Water Surface Elev.	938.67 feet on 03-10-95 STORAGE 5,744.90 Acre-feet

(for Water Year 95-96)

Max. Peak Inflow	1406.13 CFS from 1800 on 02-20-96 to 1900 on 02-20-96
Max. Peak Outflow	652.00 CFS from 1830 on 02-20-96 to 1900 on 02-20-96
Max. Water Surface Elev.	945.33 feet on 02-21-96 STORAGE 7,430.00 Acre-feet
Min. Water Surface Elev.	939.86 feet on 09-30-96 STORAGE 6,034.70 Acre-feet

**PUDDINGSTONE DAM OPERATION RECORD SUMMARY**  
**WATER YEAR 1994-1995**

	OCTOBER	NOVEMBER	DECEMBER	JANUARY
TOTAL MONTHLY INFLOW (AF)	140.00	117.50	177.00	4,001.80
TOTAL MONTHLY OUTFLOW (AF)	131.50	76.60	111.10	3,956.60
MAX. MEAN DAILY INFLOW (CFS)	25.90	10.80	18.90	536.70
TOTAL MONTHLY LOSSES (AF)	110.20	73.10	48.60	45.40
MIN. MEAN DAILY INFLOW (CFS)	0.10	0.30	0.30	0.20
MONTHLY STORAGE CHANGE	-101.70	-32.20	17.30	-0.20

	FEBRUARY	MARCH	APRIL	MAY
TOTAL MONTHLY INFLOW (AF)	1,079.60	4,666.40	285.60	96.90
TOTAL MONTHLY OUTFLOW (AF)	579.80	4,557.20	226.10	64.50
MAX. MEAN DAILY INFLOW (CFS)	163.70	525.40	30.60	3.70
TOTAL MONTHLY LOSSES (AF)	48.00	0.00	112.80	96.00
MIN. MEAN DAILY INFLOW (CFS)	1.20	1.00	0.40	0.80
MONTHLY STORAGE CHANGE	451.80	109.20	-53.30	-63.60

	JUNE	JULY	AUGUST	SEPTEMBER
TOTAL MONTHLY INFLOW (AF)	258.40	153.60	147.00	137.40
TOTAL MONTHLY OUTFLOW (AF)	65.10	61.50	53.00	44.20
MAX. MEAN DAILY INFLOW (CFS)	43.50	4.40	3.80	3.90
TOTAL MONTHLY LOSSES (AF)	147.60	206.40	234.90	206.10
MIN. MEAN DAILY INFLOW (CFS)	0.80	1.00	1.10	1.00
MONTHLY STORAGE CHANGE	45.70	-114.30	-140.90	-112.90

**PUDDINGSTONE DAM OPERATION RECORD SUMMARY**  
**WATER YEAR 1995-1996**

	OCTOBER	NOVEMBER	DECEMBER	JANUARY
TOTAL MONTHLY INFLOW (AF)	90.30	59.40	145.00	817.90
TOTAL MONTHLY OUTFLOW (AF)	49.80	19.20	15.30	15.30
MAX. MEAN DAILY INFLOW (CFS)	2.90	3.80	24.40	309.30
TOTAL MONTHLY LOSSES (AF)	132.50	87.30	62.70	62.20
MIN. MEAN DAILY INFLOW (CFS)	0.20	0.00	0.10	0.00
MONTHLY STORAGE CHANGE	-92.00	-47.10	67.00	740.40

	FEBRUARY	MARCH	APRIL	MAY
TOTAL MONTHLY INFLOW (AF)	2,102.10	651.90	147.80	92.20
TOTAL MONTHLY OUTFLOW (AF)	2,659.60	279.50	48.60	42.20
MAX. MEAN DAILY INFLOW (CFS)	438.10	72.40	8.90	2.50
TOTAL MONTHLY LOSSES (AF)	47.90	93.70	134.80	161.30
MIN. MEAN DAILY INFLOW (CFS)	0.10	0.30	0.30	0.40
MONTHLY STORAGE CHANGE	-605.40	278.70	-35.60	-111.30

	JUNE	JULY	AUGUST	SEPTEMBER
TOTAL MONTHLY INFLOW (AF)	108.00	142.60	132.80	96.70
TOTAL MONTHLY OUTFLOW (AF)	42.40	34.50	35.70	33.10
MAX. MEAN DAILY INFLOW (CFS)	3.20	3.80	3.50	2.60
TOTAL MONTHLY LOSSES (AF)	196.10	233.10	236.00	169.80
MIN. MEAN DAILY INFLOW (CFS)	0.70	1.00	1.30	0.50
MONTHLY STORAGE CHANGE	-130.50	-125.00	-138.90	-106.20



# PUDDINGSTONE DIVERSION DAM AND RESERVOIR

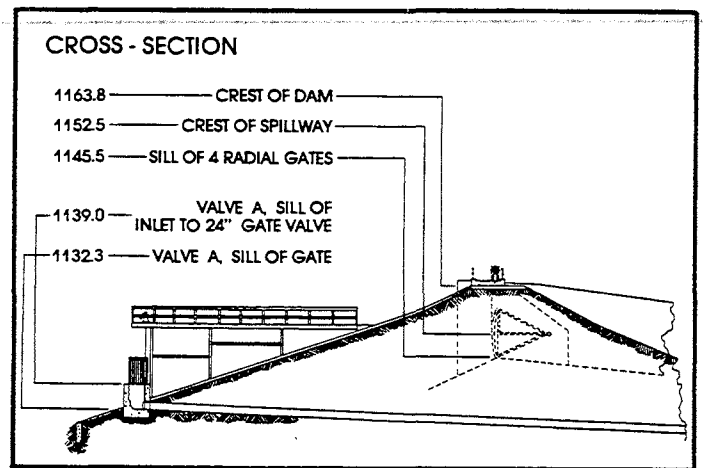
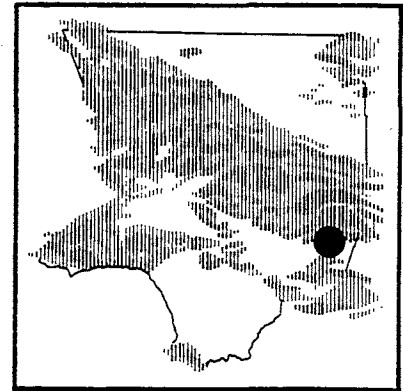
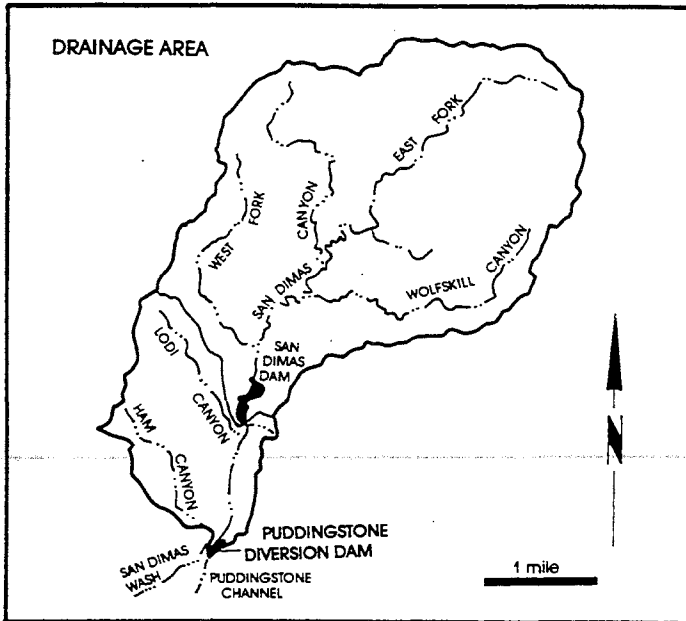

**PURPOSE** - Flood Control and Diversion of flow and Conservation.  
**DATE CONSTRUCTED** - Started September 1927. Completed July 1928.  
**LOCATION** - 2.0 miles northeast of San Dimas.  
**DRAINAGE AREA** - 3.7 square miles (uncontrolled)  
                   16.2 square miles (controlled)  
                   Total 19.9 square miles  
**CAPACITY** - 148 acre feet.  
**SPILLWAY ELEVATION** - 1,152.0 feet.

## DAM OPERATION RECORD SUMMARY

(for Water Year 94-95)

Max. Peak Inflow	251.94 CFS from 1500 on 01-10-95 to 1600 on 01-10-95
Max. Peak Outflow	292.30 CFS from 1715 on 01-10-95 to 1730 on 01-10-95
Max. Water Surface Elev.	1,152.50 feet on 04-11-95 STORAGE 205.50 Acre-feet
Min. Water Surface Elev.	1,133.00 feet on varies STORAGE 0.00 Acre-feet

(for Water Year 95-96)

Max. Peak Inflow	161.37 CFS from 1700 on 02-20-96 to 1800 on 02-20-96
Max. Peak Outflow	107.00 CFS from 0915 on 02-21-96 to 0930 on 02-21-96
Max. Water Surface Elev.	1,147.50 feet on 02-21-96 STORAGE 132.30 Acre-feet
Min. Water Surface Elev.	1,133.00 feet on varies STORAGE 0.00 Acre-feet

**PUDDINGSTONE DIVERSION DAM OPERATION RECORD SUMMARY**  
**WATER YEAR 1994-1995**

	OCTOBER	NOVEMBER	DECEMBER	JANUARY
TOTAL MONTHLY INFLOW (AF)	0.50	0.40	1.00	1,741.40
TOTAL MONTHLY OUTFLOW (AF)	0.00	0.00	1.00	1,690.90
MAX. MEAN DAILY INFLOW (CFS)	0.10	0.10	0.50	171.90
TOTAL MONTHLY LOSSES (AF)	0.00	0.00	0.00	0.00
MIN. MEAN DAILY INFLOW (CFS)	0.00	0.00	0.00	0.10
MONTHLY STORAGE CHANGE	0.50	0.40	0.00	50.50

	FEBRUARY	MARCH	APRIL	MAY
TOTAL MONTHLY INFLOW (AF)	1,850.50	3,766.10	1,249.60	904.40
TOTAL MONTHLY OUTFLOW (AF)	1,841.50	3,706.50	1,227.40	927.90
MAX. MEAN DAILY INFLOW (CFS)	145.60	210.50	32.60	28.30
TOTAL MONTHLY LOSSES (AF)	0.00	0.00	0.00	0.00
MIN. MEAN DAILY INFLOW (CFS)	12.30	14.60	14.80	9.60
MONTHLY STORAGE CHANGE	9.00	59.60	22.20	-23.50

	JUNE	JULY	AUGUST	SEPTEMBER
TOTAL MONTHLY INFLOW (AF)	593.50	750.80	485.50	4.90
TOTAL MONTHLY OUTFLOW (AF)	667.80	771.40	509.00	5.20
MAX. MEAN DAILY INFLOW (CFS)	15.00	15.10	14.70	0.80
TOTAL MONTHLY LOSSES (AF)	0.00	0.00	0.00	0.00
MIN. MEAN DAILY INFLOW (CFS)	1.50	9.30	0.50	0.00
MONTHLY STORAGE CHANGE	-74.30	-20.60	-23.50	-0.30

**PUDD. DIVERSION DAM OPERATION RECORD SUMMARY**  
**WATER YEAR 1995-1996**

	OCTOBER	NOVEMBER	DECEMBER	JANUARY
TOTAL MONTHLY INFLOW (AF)	0.40	118.00	1.80	184.30
TOTAL MONTHLY OUTFLOW (AF)	0.00	118.00	0.00	173.60
MAX. MEAN DAILY INFLOW (CFS)	0.10	8.10	0.30	10.80
TOTAL MONTHLY LOSSES (AF)	0.00	0.00	0.00	0.00
MIN. MEAN DAILY INFLOW (CFS)	0.00	0.00	0.00	0.10
MONTHLY STORAGE CHANGE	0.40	0.00	1.80	10.70

	FEBRUARY	MARCH	APRIL	MAY
TOTAL MONTHLY INFLOW (AF)	943.30	612.00	392.70	112.50
TOTAL MONTHLY OUTFLOW (AF)	873.70	650.20	414.30	98.20
MAX. MEAN DAILY INFLOW (CFS)	70.50	16.90	9.20	6.90
TOTAL MONTHLY LOSSES (AF)	0.00	0.00	0.00	0.00
MIN. MEAN DAILY INFLOW (CFS)	0.00	3.20	1.20	0.00
MONTHLY STORAGE CHANGE	69.60	-38.20	-21.60	14.30

	JUNE	JULY	AUGUST	SEPTEMBER
TOTAL MONTHLY INFLOW (AF)	264.20	358.00	57.50	0.00
TOTAL MONTHLY OUTFLOW (AF)	296.90	306.40	113.10	0.00
MAX. MEAN DAILY INFLOW (CFS)	10.60	10.90	6.90	0.00
TOTAL MONTHLY LOSSES (AF)	0.00	0.00	0.00	0.00
MIN. MEAN DAILY INFLOW (CFS)	0.00	0.00	0.00	0.00
MONTHLY STORAGE CHANGE	-32.70	51.60	-55.60	0.00

# SAN DIMAS DAM AND RESERVOIR

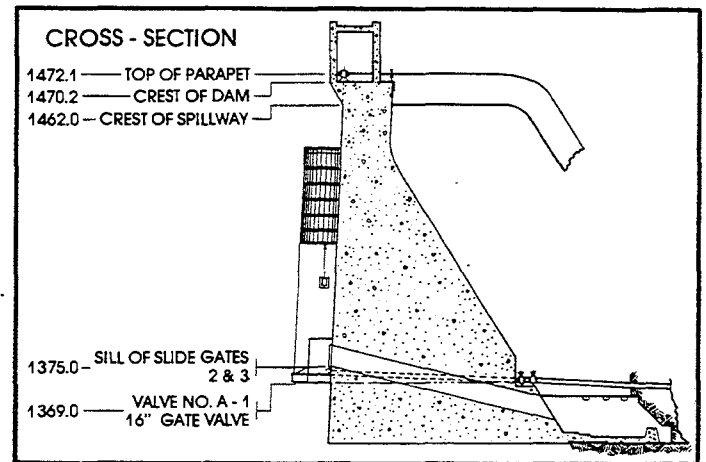
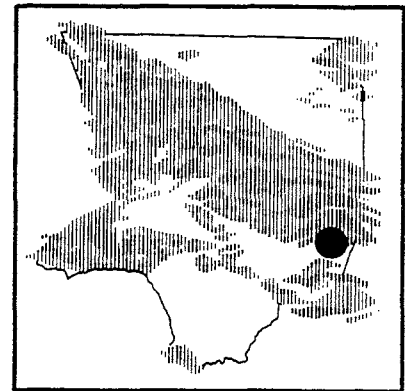
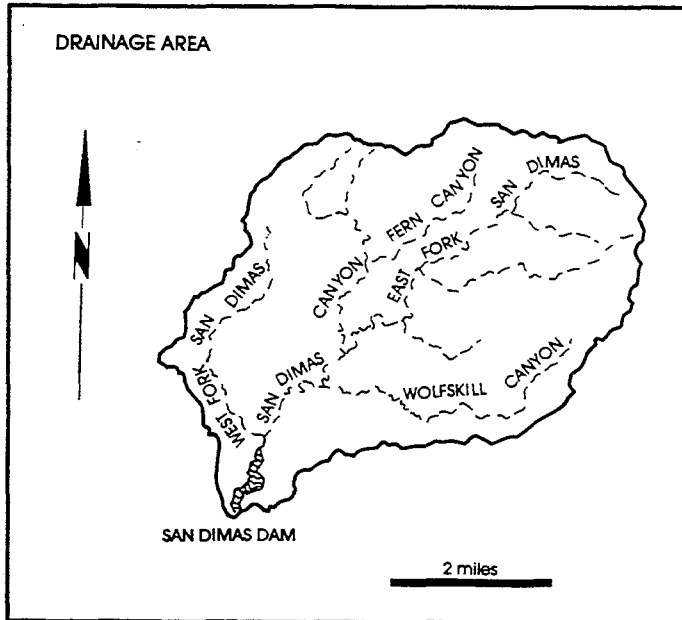

PURPOSE - Flood Control and Conservation.  
 DATE CONSTRUCTED - Started November 1920. Completed September 1922.  
 LOCATION - 3.0 miles northeast of San Dimas.  
 DRAINAGE AREA - 16.2 square miles.  
 CAPACITY - 1,515 acre - feet.  
 SPILLWAY ELEVATION - 1,462.0 feet.

## DAM OPERATION RECORD SUMMARY

(for Water Year 94-95)

Max. Peak Inflow	363.30 CFS from 1600 on 01-10-95 to 1700 on 01-10-95
Max. Peak Outflow	248.00 CFS from 0030 on 03-06-95 to 0045 on 03-06-95
Max. Water Surface Elev.	1,462.90 feet on 03-16-95 STORAGE 1,613.00 Acre-feet
Min. Water Surface Elev.	1,418.50 feet on 10-01-94 STORAGE 318.80 Acre-feet

(for Water Year 95-96)

Max. Peak Inflow	418.24 CFS from 1700 on 02-20-96 to 1800 on 02-20-96
Max. Peak Outflow	77.50 CFS from 1015 on 02-22-96 to 1045 on 02-22-96
Max. Water Surface Elev.	1,457.72 feet on 02-22-96 STORAGE 1,413.40 Acre-feet
Min. Water Surface Elev.	1,419.40 feet on varies STORAGE 336.90 Acre-feet

**SAN DIMAS DAM OPERATION RECORD SUMMARY**  
**WATER YEAR 1994-1995**

	OCTOBER	NOVEMBER	DECEMBER	JANUARY
TOTAL MONTHLY INFLOW (AF)	104.70	82.70	109.10	1,840.90
TOTAL MONTHLY OUTFLOW (AF)	62.50	26.40	32.70	1,057.40
MAX. MEAN DAILY INFLOW (CFS)	4.50	3.40	3.70	167.40
TOTAL MONTHLY LOSSES (AF)	5.80	4.30	2.80	4.20
MIN. MEAN DAILY INFLOW (CFS)	0.80	0.80	1.20	1.70
MONTHLY STORAGE CHANGE	36.40	52.00	73.60	779.30

	FEBRUARY	MARCH	APRIL	MAY
TOTAL MONTHLY INFLOW (AF)	1,478.90	3,216.50	1,243.00	1,040.70
TOTAL MONTHLY OUTFLOW (AF)	1,744.10	2,602.30	1,236.50	1,222.00
MAX. MEAN DAILY INFLOW (CFS)	177.00	129.40	29.20	19.60
TOTAL MONTHLY LOSSES (AF)	4.60	6.80	12.10	10.00
MIN. MEAN DAILY INFLOW (CFS)	7.20	15.20	15.40	14.20
MONTHLY STORAGE CHANGE	-269.80	607.40	-5.60	-191.30

	JUNE	JULY	AUGUST	SEPTEMBER
TOTAL MONTHLY INFLOW (AF)	484.10	241.10	159.80	100.40
TOTAL MONTHLY OUTFLOW (AF)	596.20	644.40	525.40	51.00
MAX. MEAN DAILY INFLOW (CFS)	13.20	7.80	4.70	2.50
TOTAL MONTHLY LOSSES (AF)	14.20	20.80	18.70	0.00
MIN. MEAN DAILY INFLOW (CFS)	5.00	1.60	1.40	1.10
MONTHLY STORAGE CHANGE	-126.30	-424.10	-384.30	49.40



**SAN DIMAS DAM OPERATION RECORD SUMMARY**  
**WATER YEAR 1995-1996**

	OCTOBER	NOVEMBER	DECEMBER	JANUARY
TOTAL MONTHLY INFLOW (AF)	144.40	167.90	206.70	275.00
TOTAL MONTHLY OUTFLOW (AF)	64.70	240.20	61.30	319.10
MAX. MEAN DAILY INFLOW (CFS)	3.80	4.00	6.10	28.80
TOTAL MONTHLY LOSSES (AF)	7.70	4.00	3.60	3.30
MIN. MEAN DAILY INFLOW (CFS)	1.30	1.70	2.30	2.00
MONTHLY STORAGE CHANGE	72.00	-76.30	141.80	-47.40

	FEBRUARY	MARCH	APRIL	MAY
TOTAL MONTHLY INFLOW (AF)	1,161.90	987.90	441.10	274.10
TOTAL MONTHLY OUTFLOW (AF)	756.40	692.20	611.70	257.90
MAX. MEAN DAILY INFLOW (CFS)	148.50	43.10	10.90	5.60
TOTAL MONTHLY LOSSES (AF)	3.60	9.50	12.80	15.90
MIN. MEAN DAILY INFLOW (CFS)	3.20	6.30	4.60	3.50
MONTHLY STORAGE CHANGE	401.90	286.20	-183.40	0.30

	JUNE	JULY	AUGUST	SEPTEMBER
TOTAL MONTHLY INFLOW (AF)	187.80	96.90	46.60	46.00
TOTAL MONTHLY OUTFLOW (AF)	320.30	585.50	141.00	46.80
MAX. MEAN DAILY INFLOW (CFS)	6.10	4.70	1.90	1.50
TOTAL MONTHLY LOSSES (AF)	15.90	18.10	11.90	9.70
MIN. MEAN DAILY INFLOW (CFS)	1.40	0.20	0.20	0.30
MONTHLY STORAGE CHANGE	-148.40	-506.70	-106.30	-10.50

# SAN GABRIEL DAM AND RESERVOIR

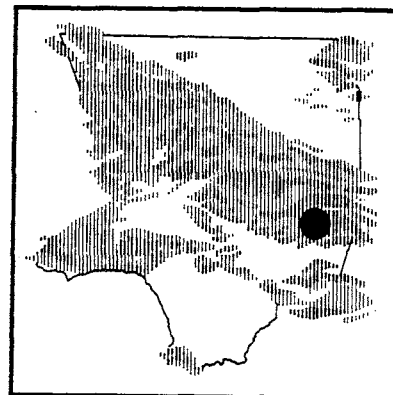
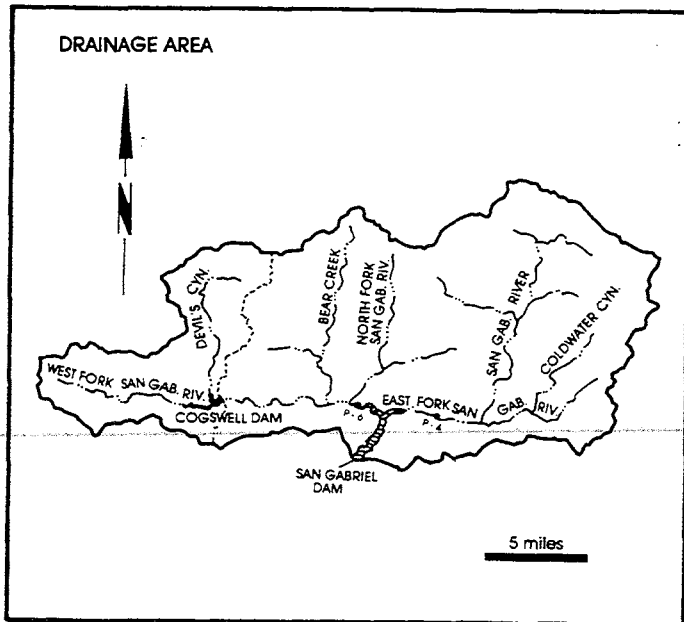

**PURPOSE** - Flood Control and Conservation.  
**DATE CONSTRUCTED** - Started December 1932. Completed July 1939.  
**LOCATION** - San Gabriel Canyon, 7.5 miles north of Azusa.  
**DRAINAGE AREA** - 163.5 square miles (uncontrolled)  
                   39.2 square miles (controlled)  
                   Total 202.7 square miles  
 (includes Cogswell drainage)  
**CAPACITY** - 41,549 acre - feet.  
**SPILLWAY ELEVATION** - 1,453 feet.

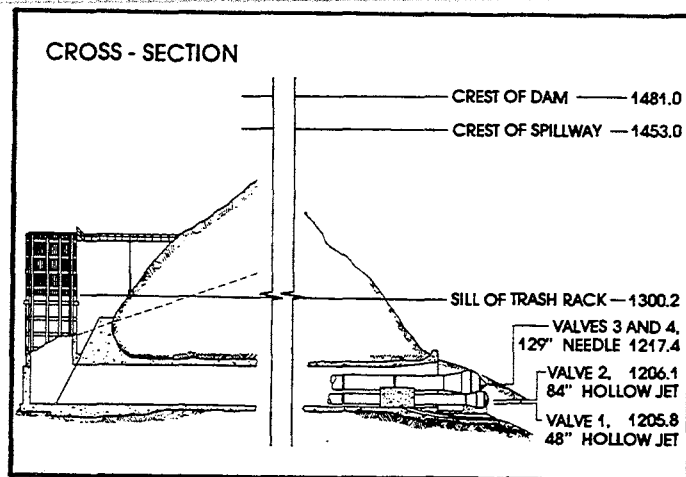

## DAM OPERATION RECORD SUMMARY

(for Water Year 94-95)

Max. Peak Inflow	6996.36 CFS from 1700 on 01-10-95 to 1800 on 01-10-95
Max. Peak Outflow	3792.00 CFS from 0400 on 03-06-95 to 1615 on 03-06-95
Max. Water Surface Elev.	1,454.08 feet on 03-21-95 STORAGE 46,422.00 Acre-feet
Min. Water Surface Elev.	1,321.04 feet on 12-20-94 STORAGE 2,899.00 Acre-feet

(for Water Year 95-96)

Max. Peak Inflow	3822.15 CFS from 1100 on 02-21-96 to 1200 on 02-21-96
Max. Peak Outflow	2165.50 CFS from 1000 on 11-08-95 to 1030 on 11-08-95
Max. Water Surface Elev.	1,450.42 feet on 04-18-96 STORAGE 11,442.00 Acre-feet
Min. Water Surface Elev.	1,330.40 feet on varies STORAGE 4,096.00 Acre-feet

**SAN GABRIEL DAM OPERATION RECORD SUMMARY**  
**WATER YEAR 1994-1995**

	OCTOBER	NOVEMBER	DECEMBER	JANUARY
TOTAL MONTHLY INFLOW (AF)	1,254.70	1,606.70	1,588.10	55,218.60
TOTAL MONTHLY OUTFLOW (AF)	2,293.50	2,216.10	1,717.70	25,781.00
MAX. MEAN DAILY INFLOW (CFS)	49.80	139.20	45.90	3,810.70
TOTAL MONTHLY LOSSES (AF)	86.40	44.00	35.50	33.90
MIN. MEAN DAILY INFLOW (CFS)	12.80	17.10	19.50	27.90
MONTHLY STORAGE CHANGE	-1,125.20	-653.40	-165.10	29,403.70

	FEBRUARY	MARCH	APRIL	MAY
TOTAL MONTHLY INFLOW (AF)	42,145.70	75,883.30	29,686.40	17,763.50
TOTAL MONTHLY OUTFLOW (AF)	34,127.40	70,081.40	31,736.10	21,379.20
MAX. MEAN DAILY INFLOW (CFS)	3,565.20	3,210.70	703.00	370.30
TOTAL MONTHLY LOSSES (AF)	117.00	156.30	223.30	134.10
MIN. MEAN DAILY INFLOW (CFS)	250.50	461.90	355.40	212.10
MONTHLY STORAGE CHANGE	7,901.30	5,645.60	-2,273.00	-3,749.80

	JUNE	JULY	AUGUST	SEPTEMBER
TOTAL MONTHLY INFLOW (AF)	11,032.00	6,182.70	3,412.50	2,493.40
TOTAL MONTHLY OUTFLOW (AF)	16,919.60	17,388.50	12,610.70	6,634.30
MAX. MEAN DAILY INFLOW (CFS)	243.50	137.70	89.00	68.90
TOTAL MONTHLY LOSSES (AF)	250.00	306.20	225.00	189.70
MIN. MEAN DAILY INFLOW (CFS)	134.70	71.20	23.50	31.80
MONTHLY STORAGE CHANGE	-6,137.60	-11,512.00	-9,423.20	-4,330.60

**SAN GABRIEL DAM OPERATION RECORD SUMMARY**  
**WATER YEAR 1995-1996**

	OCTOBER	NOVEMBER	DECEMBER	JANUARY
TOTAL MONTHLY INFLOW (AF)	2,155.80	2,198.10	2,601.40	3,315.80
TOTAL MONTHLY OUTFLOW (AF)	4,370.40	3,686.30	2,644.00	2,644.00
MAX. MEAN DAILY INFLOW (CFS)	39.60	58.40	66.90	423.60
TOTAL MONTHLY LOSSES (AF)	134.20	70.70	45.20	41.30
MIN. MEAN DAILY INFLOW (CFS)	29.20	29.20	32.40	37.60
MONTHLY STORAGE CHANGE	-2,348.80	-1,558.90	-87.80	630.50

	FEBRUARY	MARCH	APRIL	MAY
TOTAL MONTHLY INFLOW (AF)	21,806.30	20,934.00	8,541.50	4,866.60
TOTAL MONTHLY OUTFLOW (AF)	2,044.60	4,169.30	8,965.90	4,696.30
MAX. MEAN DAILY INFLOW (CFS)	2,994.80	612.50	207.80	99.90
TOTAL MONTHLY LOSSES (AF)	55.40	178.10	277.00	235.00
MIN. MEAN DAILY INFLOW (CFS)	52.60	154.80	102.90	57.20
MONTHLY STORAGE CHANGE	19,706.30	16,586.60	-701.40	-64.70

	JUNE	JULY	AUGUST	SEPTEMBER
TOTAL MONTHLY INFLOW (AF)	2,826.50	1,719.90	937.60	818.80
TOTAL MONTHLY OUTFLOW (AF)	10,285.30	10,224.00	9,768.20	7,034.40
MAX. MEAN DAILY INFLOW (CFS)	56.70	49.30	39.50	33.40
TOTAL MONTHLY LOSSES (AF)	329.10	318.90	218.60	171.80
MIN. MEAN DAILY INFLOW (CFS)	22.30	6.10	2.00	2.50
MONTHLY STORAGE CHANGE	-7,787.90	-8,823.00	-9,049.20	-6,387.40

# SANTA ANITA DAM AND RESERVOIR

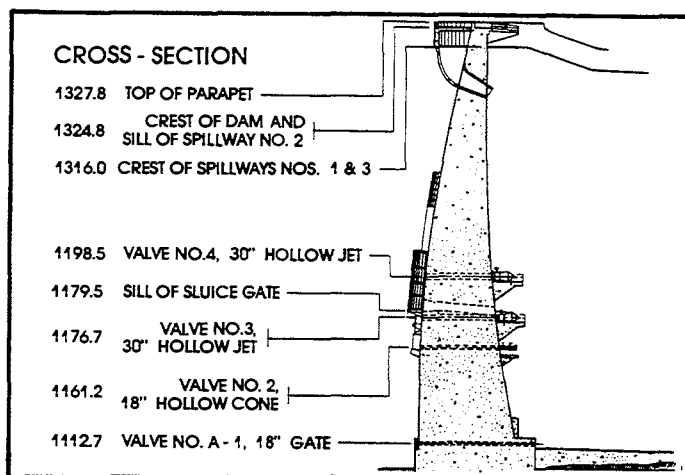
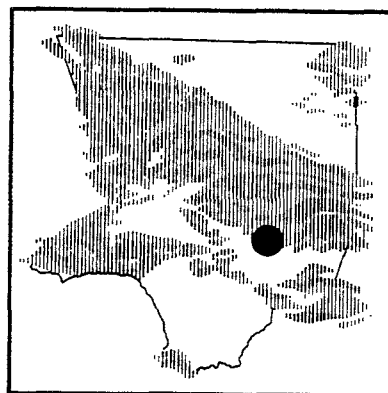
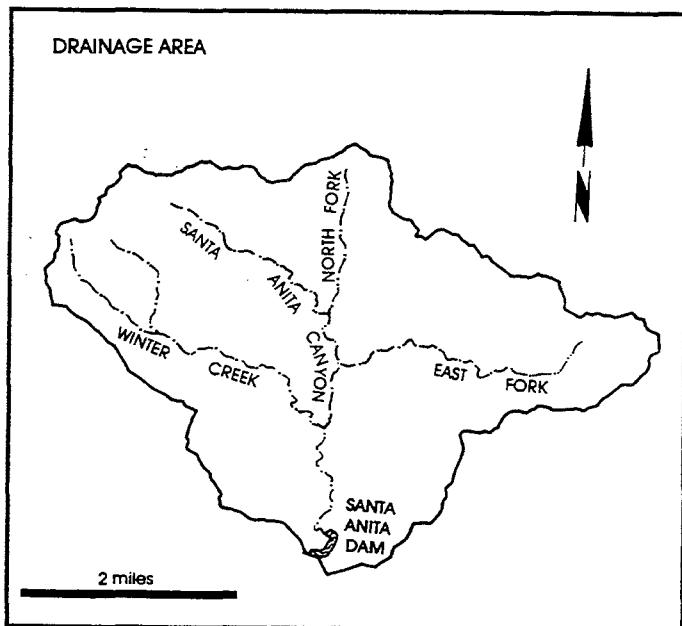

PURPOSE - Flood Control and Conservation.  
 DATE CONSTRUCTED - Started October 1924. Completed March 1927.  
 LOCATION - 2.5 miles north of Arcadia  
 DRAINAGE AREA - 10.8 square miles.  
 CAPACITY - 836 acre - feet.  
 SPILLWAY ELEVATION - 1,316.0 feet.

## DAM OPERATION RECORD SUMMARY

(for Water Year 94-95)

Max. Peak Inflow	587.06 CFS from 1200 on 01-10-95 to 1300 on 01-10-95
Max. Peak Outflow	408.00 CFS from 0835 on 01-11-95 to 0935 on 01-11-95
Max. Water Surface Elev.	1,298.30 feet on 01-11-95 STORAGE 603.60 Acre-feet
Min. Water Surface Elev.	1,236.75 feet on 11-04-94 STORAGE 103.50 Acre-feet

(for Water Year 95-96)

Max. Peak Inflow	480.57 CFS from 2000 on 02-21-96 to 2100 on 02-21-96
Max. Peak Outflow	310.00 CFS from 2045 on 02-21-96 to 2145 on 02-21-96
Max. Water Surface Elev.	1,296.30 feet on 02-21-96 STORAGE 580.20 Acre-feet
Min. Water Surface Elev.	1,243.00 feet on varies STORAGE 136.90 Acre-feet



**SANTA ANITA DAM OPERATION RECORD SUMMARY**  
**WATER YEAR 1994-1995**

	OCTOBER	NOVEMBER	DECEMBER	JANUARY
TOTAL MONTHLY INFLOW (AF)	25.80	44.40	56.40	2,597.00
TOTAL MONTHLY OUTFLOW (AF)	30.70	30.70	30.70	2,318.50
MAX. MEAN DAILY INFLOW (CFS)	0.70	1.30	1.90	241.70
TOTAL MONTHLY LOSSES (AF)	2.10	1.50	1.20	0.80
MIN. MEAN DAILY INFLOW (CFS)	0.10	0.20	0.70	1.10
MONTHLY STORAGE CHANGE	-7.00	12.20	24.50	277.70

	FEBRUARY	MARCH	APRIL	MAY
TOTAL MONTHLY INFLOW (AF)	1,668.70	4,241.20	1,801.40	849.10
TOTAL MONTHLY OUTFLOW (AF)	1,724.20	4,201.00	1,806.50	857.50
MAX. MEAN DAILY INFLOW (CFS)	187.50	165.20	43.00	18.70
TOTAL MONTHLY LOSSES (AF)	1.90	2.30	3.70	1.20
MIN. MEAN DAILY INFLOW (CFS)	9.60	18.60	21.00	8.40
MONTHLY STORAGE CHANGE	-57.40	37.90	-8.80	-9.60

	JUNE	JULY	AUGUST	SEPTEMBER
TOTAL MONTHLY INFLOW (AF)	565.80	315.50	166.70	106.60
TOTAL MONTHLY OUTFLOW (AF)	621.80	457.20	202.50	0.00
MAX. MEAN DAILY INFLOW (CFS)	15.00	8.40	4.00	2.10
TOTAL MONTHLY LOSSES (AF)	2.70	3.60	3.50	3.50
MIN. MEAN DAILY INFLOW (CFS)	7.10	0.60	1.60	1.60
MONTHLY STORAGE CHANGE	-58.70	-145.30	-39.30	103.10

**SANTA ANITA DAM OPERATION RECORD SUMMARY**  
**WATER YEAR 1995-1996**

	OCTOBER	NOVEMBER	DECEMBER	JANUARY
TOTAL MONTHLY INFLOW (AF)	104.70	108.80	129.60	191.60
TOTAL MONTHLY OUTFLOW (AF)	190.60	96.40	102.10	132.50
MAX. MEAN DAILY INFLOW (CFS)	4.20	2.70	4.20	32.10
TOTAL MONTHLY LOSSES (AF)	2.50	2.20	1.50	1.40
MIN. MEAN DAILY INFLOW (CFS)	0.20	1.20	0.60	0.90
MONTHLY STORAGE CHANGE	-88.40	10.20	26.00	57.70

	FEBRUARY	MARCH	APRIL	MAY
TOTAL MONTHLY INFLOW (AF)	1,558.40	1,271.90	463.80	330.10
TOTAL MONTHLY OUTFLOW (AF)	1,392.80	1,244.20	570.80	373.90
MAX. MEAN DAILY INFLOW (CFS)	274.20	43.60	13.00	9.30
TOTAL MONTHLY LOSSES (AF)	1.10	1.90	5.30	2.20
MIN. MEAN DAILY INFLOW (CFS)	2.80	12.40	5.10	3.90
MONTHLY STORAGE CHANGE	164.50	25.80	-112.30	-46.00

	JUNE	JULY	AUGUST	SEPTEMBER
TOTAL MONTHLY INFLOW (AF)	174.60	87.10	32.70	41.00
TOTAL MONTHLY OUTFLOW (AF)	162.00	116.60	0.00	153.30
MAX. MEAN DAILY INFLOW (CFS)	5.80	4.10	1.00	1.80
TOTAL MONTHLY LOSSES (AF)	3.40	3.90	4.30	3.20
MIN. MEAN DAILY INFLOW (CFS)	1.60	0.70	0.20	0.10
MONTHLY STORAGE CHANGE	9.20	-33.40	28.40	-115.50

# SAWPIT DAM AND RESERVOIR

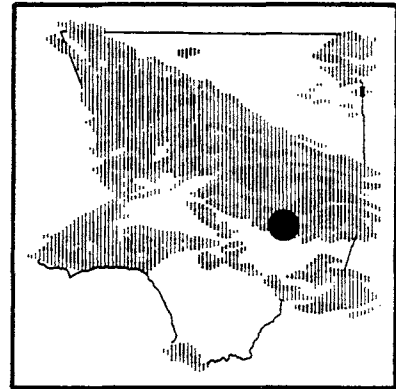
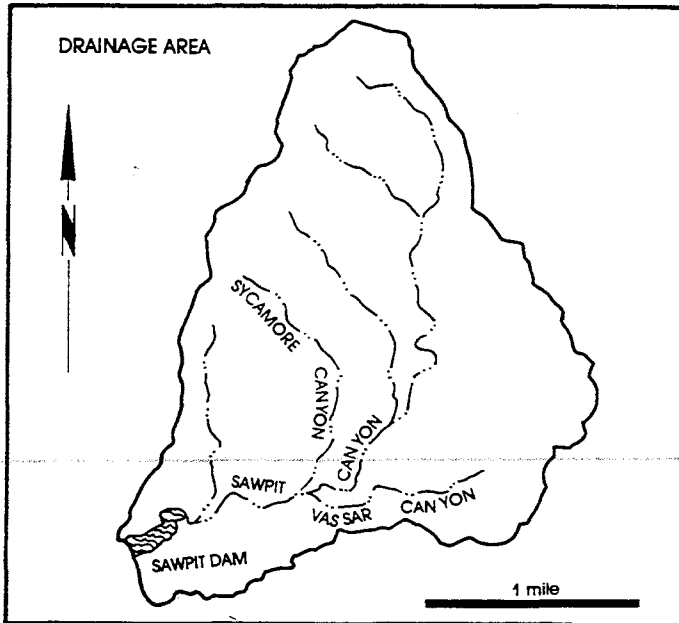

PURPOSE - Flood Control and Conservation.  
 DATE CONSTRUCTED - Started March 1926. Completed June 1927.  
 LOCATION - 2.0 miles north of Monrovia.  
 DRAINAGE AREA - 3.2 square miles.  
 CAPACITY - 391 acre - feet.  
 SPILLWAY ELEVATION - 1,360.0 feet.

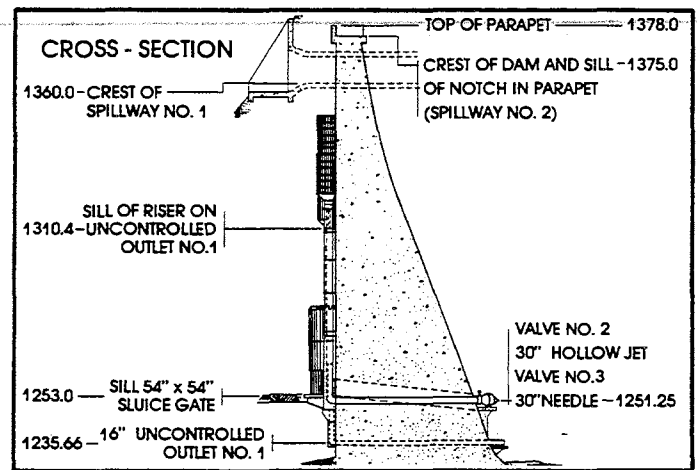

## DAM OPERATION RECORD SUMMARY

(for Water Year 94-95)

Max. Peak Inflow	136.35 CFS from 1100 on 01-10-95 to 1200 on 01-10-95
Max. Peak Outflow	85.30 CFS from 1915 on 03-05-95 to 1930 on 03-05-95
Max. Water Surface Elev.	1,324.10 feet on 01-11-95 STORAGE 154.30 Acre-feet
Min. Water Surface Elev.	1,310.30 feet on varies STORAGE 95.90 Acre-feet

(for Water Year 95-96)

Max. Peak Inflow	48.68 CFS from 0900 on 02-21-96 to 1000 on 02-21-96
Max. Peak Outflow	35.10 CFS from 0045 on 02-22-96 to 0100 on 02-22-96
Max. Water Surface Elev.	1,313.90 feet on 02-20-96 STORAGE 109.30 Acre-feet
Min. Water Surface Elev.	1,310.30 feet on varies STORAGE 95.90 Acre-feet

## SAWPIT DAM OPERATION RECORD SUMMARY

### WATER YEAR 1994-1995

	OCTOBER	NOVEMBER	DECEMBER	JANUARY
TOTAL MONTHLY INFLOW (AF)	99.20	99.60	103.30	683.00
TOTAL MONTHLY OUTFLOW (AF)	99.20	99.60	103.30	682.30
MAX. MEAN DAILY INFLOW (CFS)	2.00	2.10	2.40	76.50
TOTAL MONTHLY LOSSES (AF)	0.00	0.00	0.00	0.00
MIN. MEAN DAILY INFLOW (CFS)	1.50	1.50	1.50	1.60
MONTHLY STORAGE CHANGE	0.00	0.00	0.00	0.70

	FEBRUARY	MARCH	APRIL	MAY
TOTAL MONTHLY INFLOW (AF)	335.20	924.00	358.90	215.40
TOTAL MONTHLY OUTFLOW (AF)	335.20	923.30	359.60	215.60
MAX. MEAN DAILY INFLOW (CFS)	39.50	57.40	7.80	4.00
TOTAL MONTHLY LOSSES (AF)	0.00	0.00	0.00	0.00
MIN. MEAN DAILY INFLOW (CFS)	3.00	4.10	4.20	3.00
MONTHLY STORAGE CHANGE	0.00	0.70	-0.70	-0.20

	JUNE	JULY	AUGUST	SEPTEMBER
TOTAL MONTHLY INFLOW (AF)	197.20	193.60	176.00	187.70
TOTAL MONTHLY OUTFLOW (AF)	197.20	193.60	175.90	187.60
MAX. MEAN DAILY INFLOW (CFS)	4.20	3.40	3.00	3.60
TOTAL MONTHLY LOSSES (AF)	0.00	0.00	0.00	0.00
MIN. MEAN DAILY INFLOW (CFS)	3.00	2.90	2.70	2.80
MONTHLY STORAGE CHANGE	0.00	0.00	0.10	0.10

## SAWPIT DAM OPERATION RECORD SUMMARY

### WATER YEAR 1995-1996

	OCTOBER	NOVEMBER	DECEMBER	JANUARY
TOTAL MONTHLY INFLOW (AF)	190.30	202.50	181.00	168.70
TOTAL MONTHLY OUTFLOW (AF)	190.60	202.30	181.00	167.20
MAX. MEAN DAILY INFLOW (CFS)	3.20	3.50	3.40	7.00
TOTAL MONTHLY LOSSES (AF)	0.00	0.00	0.00	0.00
MIN. MEAN DAILY INFLOW (CFS)	2.90	3.40	2.30	2.20
MONTHLY STORAGE CHANGE	-0.30	0.20	0.00	1.50

	FEBRUARY	MARCH	APRIL	MAY
TOTAL MONTHLY INFLOW (AF)	361.40	340.50	262.60	175.90
TOTAL MONTHLY OUTFLOW (AF)	362.20	340.00	263.00	176.70
MAX. MEAN DAILY INFLOW (CFS)	38.30	14.70	4.80	3.10
TOTAL MONTHLY LOSSES (AF)	0.00	0.00	0.00	0.00
MIN. MEAN DAILY INFLOW (CFS)	2.60	3.80	3.50	2.70
MONTHLY STORAGE CHANGE	-0.80	0.50	-0.40	-0.80

	JUNE	JULY	AUGUST	SEPTEMBER
TOTAL MONTHLY INFLOW (AF)	153.30	128.80	116.60	99.70
TOTAL MONTHLY OUTFLOW (AF)	153.70	129.50	116.60	99.40
MAX. MEAN DAILY INFLOW (CFS)	2.90	2.50	2.30	1.90
TOTAL MONTHLY LOSSES (AF)	0.00	0.00	0.00	0.00
MIN. MEAN DAILY INFLOW (CFS)	2.40	1.80	1.40	1.50
MONTHLY STORAGE CHANGE	-0.40	-0.70	0.00	0.30

# THOMPSON CREEK DAM AND RESERVOIR

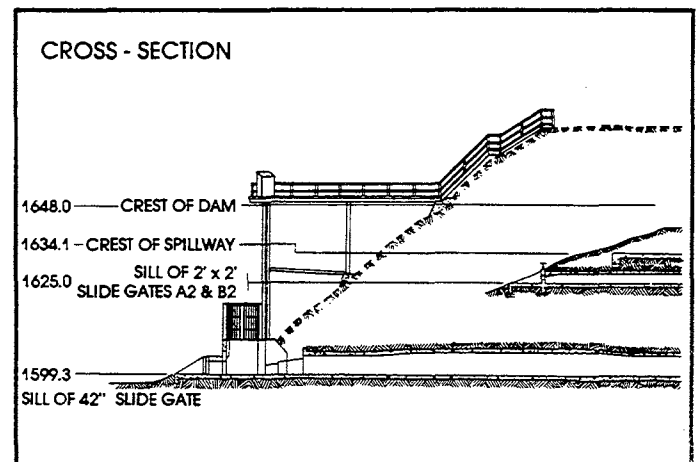
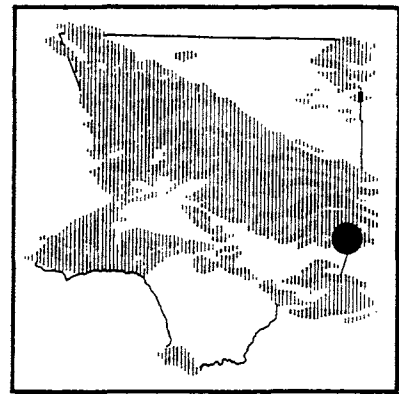
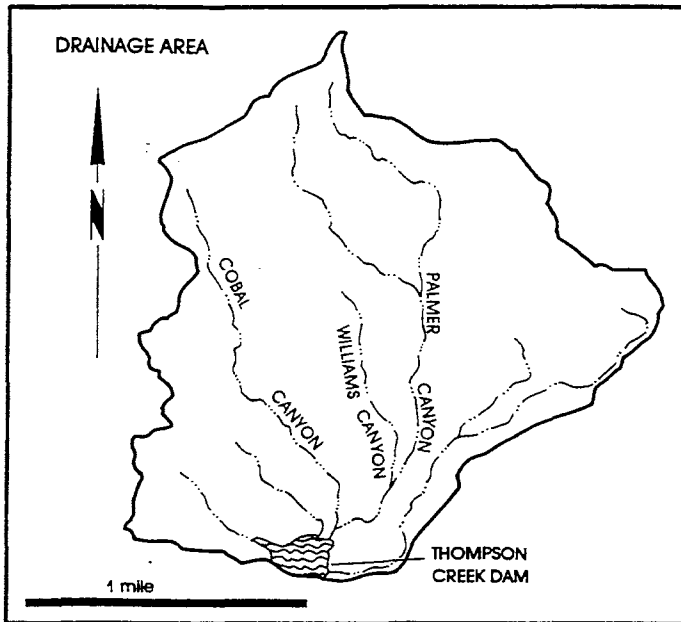

**PURPOSE** - Flood Control and Conservation.  
**DATE CONSTRUCTED** - Started September 1925. Completed March 1928.  
**LOCATION** - 3.0 miles north of Claremont.  
**DRAINAGE AREA** - 3.5 square miles.  
**CAPACITY** - 447.5 acre - feet.  
**SPILLWAY ELEVATION** - 1,634 feet.

## DAM OPERATION RECORD SUMMARY

(for Water Year 94-95)

Max. Peak Inflow	82.12 CFS from 1600 on 01-10-95 to 1700 on 01-10-95
Max. Peak Outflow	63.00 CFS from 0115 on 03-06-95 to 0130 on 03-06-95
Max. Water Surface Elev.	1,609.95 feet on 03-06-95 STORAGE 73.10 Acre-feet
Min. Water Surface Elev.	1,600.00 feet on varies STORAGE 0.00 Acre-feet

(for Water Year 95-96)

Max. Peak Inflow	73.27 CFS from 1900 on 02-20-96 to 2000 on 02-20-96
Max. Peak Outflow	35.40 CFS from 0800 on 02-21-96 to 0900 on 02-21-96
Max. Water Surface Elev.	1,606.60 feet on 02-21-96 STORAGE 34.30 Acre-feet
Min. Water Surface Elev.	1,600.00 feet on varies STORAGE 0.00 Acre-feet



**THOMPSON CREEK DAM OPERATION RECORD SUMMARY**  
**WATER YEAR 1994-1995**

	OCTOBER	NOVEMBER	DECEMBER	JANUARY
TOTAL MONTHLY INFLOW (AF)	0.00	0.00	0.00	90.00
TOTAL MONTHLY OUTFLOW (AF)	0.00	0.00	0.00	56.50
MAX. MEAN DAILY INFLOW (CFS)	0.00	0.00	0.00	22.60
TOTAL MONTHLY LOSSES (AF)	0.00	0.00	0.00	0.00
MIN. MEAN DAILY INFLOW (CFS)	0.00	0.00	0.00	0.00
MONTHLY STORAGE CHANGE	0.00	0.00	0.00	33.50

	FEBRUARY	MARCH	APRIL	MAY
TOTAL MONTHLY INFLOW (AF)	11.70	208.90	12.90	6.10
TOTAL MONTHLY OUTFLOW (AF)	21.40	188.80	56.70	6.10
MAX. MEAN DAILY INFLOW (CFS)	1.80	34.70	0.70	0.30
TOTAL MONTHLY LOSSES (AF)	0.00	0.00	0.00	0.00
MIN. MEAN DAILY INFLOW (CFS)	0.00	0.00	0.00	0.00
MONTHLY STORAGE CHANGE	-9.70	20.10	-43.80	0.00

	JUNE	JULY	AUGUST	SEPTEMBER
TOTAL MONTHLY INFLOW (AF)	0.20	0.00	0.00	0.00
TOTAL MONTHLY OUTFLOW (AF)	0.20	0.00	0.00	0.00
MAX. MEAN DAILY INFLOW (CFS)	0.10	0.00	0.00	0.00
TOTAL MONTHLY LOSSES (AF)	0.00	0.00	0.00	0.00
MIN. MEAN DAILY INFLOW (CFS)	0.00	0.00	0.00	0.00
MONTHLY STORAGE CHANGE	0.00	0.00	0.00	0.00

**THOMPSON CREEK DAM OPERATION RECORD SUMMARY**  
**WATER YEAR 1995-1996**

	OCTOBER	NOVEMBER	DECEMBER	JANUARY
TOTAL MONTHLY INFLOW (AF)	0.00	0.00	0.00	25.10
TOTAL MONTHLY OUTFLOW (AF)	0.00	0.00	0.00	20.00
MAX. MEAN DAILY INFLOW (CFS)	0.00	0.00	0.00	12.70
TOTAL MONTHLY LOSSES (AF)	0.00	0.00	0.00	0.00
MIN. MEAN DAILY INFLOW (CFS)	0.00	0.00	0.00	0.00
MONTHLY STORAGE CHANGE	0.00	0.00	0.00	5.10

	FEBRUARY	MARCH	APRIL	MAY
TOTAL MONTHLY INFLOW (AF)	311.50	41.90	13.50	0.00
TOTAL MONTHLY OUTFLOW (AF)	316.60	41.90	13.50	0.00
MAX. MEAN DAILY INFLOW (CFS)	31.10	1.70	0.40	0.00
TOTAL MONTHLY LOSSES (AF)	0.00	0.00	0.00	0.00
MIN. MEAN DAILY INFLOW (CFS)	0.30	0.00	0.00	0.00
MONTHLY STORAGE CHANGE	-5.10	0.00	0.00	0.00

	JUNE	JULY	AUGUST	SEPTEMBER
TOTAL MONTHLY INFLOW (AF)	0.00	0.00	0.00	0.00
TOTAL MONTHLY OUTFLOW (AF)	0.00	0.00	0.00	0.00
MAX. MEAN DAILY INFLOW (CFS)	0.00	0.00	0.00	0.00
TOTAL MONTHLY LOSSES (AF)	0.00	0.00	0.00	0.00
MIN. MEAN DAILY INFLOW (CFS)	0.00	0.00	0.00	0.00
MONTHLY STORAGE CHANGE	0.00	0.00	0.00	0.00



# **EROSION CONTROL**

## **EROSION CONTROL**

Each year eroded material in various forms (rock, sand, trees, etc.) flows out of the mountain watersheds of Los Angeles County. In an effort to control this potentially disruptive force, the Department maintains a series of debris basins in canyon mouths and upstream stabilization structures in selected watersheds.

### **DEBRIS BASINS**

The purpose of a debris basin is to entrap the sediment flows emanating from the canyon and let the relatively desilted water pass into the downstream flood control channels.

In the 1994-95 Water Year, the Department maintained 114 debris basins. The combined total maximum capacity of the basins is approximately 7,744,850 cubic yards. The Department cleaned out 28 debris basins. The total amount of sediment removed was 336,200 cubic yards.

In the 1995-96 Water Year, the Department maintained 115 debris basins. The combined total maximum capacity of the basins is approximately 7,765,000 cubic yards. The Department cleaned out one debris basin. The total amount of sediment removed was 29,000 cubic yards.

Records of sediment inflow at individual debris basins and amounts removed from the debris basins are available in the Department's Hydraulic/Water Conservation Division.

### **STABILIZATION STRUCTURES**

The Department has constructed stabilization structures to control erosion in natural canyons. These structures serve to prevent downcutting by stabilizing alluvium deposits. In addition, they store debris generated by the watershed and serve to stabilize side banks, reducing side slope sloughing and bank erosion.

In the 1994-95 Water Year, the Department maintained 219 stabilization structures in 47 major watersheds.

In the 1995-96 Water Year, the Department maintained 217 stabilization structures in 47 major watersheds. No structures have been constructed since the 1973-74 water year.

### **EMERGENCY STRUCTURES**

The Department has constructed emergency structures (rail and timber) to entrap the debris from burned watersheds. The structures serve to protect improvements (road, channel, residence, etc.) located downstream of the watersheds.

In the 1994-95 Water Year, 33 emergency structures existed with a total maximum capacity of 266,400 cubic yards. Two major fires (over 500 acres each) burned 1,070 acres in that water year.

In the 1995-96 Water Year, 32 emergency structures existed with a total maximum capacity of 253,000 cubic yards. Seven major fires (over 500 acres each) burned 26,100 acres in this water year.

Note: (This only accounts for all fires occurring between October 1, 1995 and September 30, 1996.)



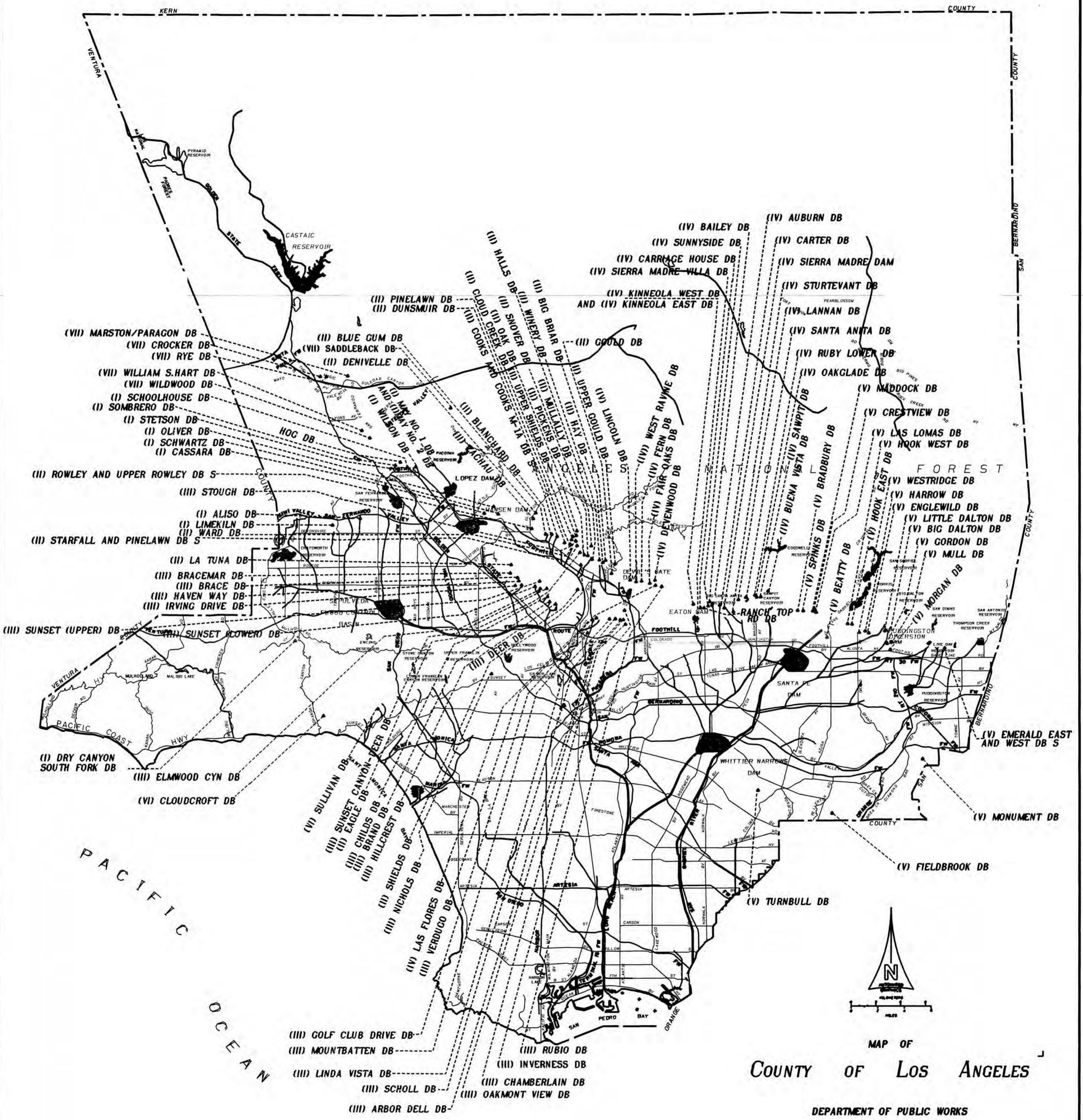

- (VII) MARSTON/PARAGON DB
- (VII) CROCKER DB
- (VII) RYE DB
- (VII) WILLIAM S. HART DB
- (VII) WILDWOOD DB
- (I) SCHOOLHOUSE DB
- (I) SOMBRERO DB
- (I) STETSON DB
- (I) OLIVER DB
- (I) SCHWARTZ DB
- (I) CASSARA DB

- (III) ROWLEY AND UPPER ROWLEY DB S
- (III) STOUGH DB
- (I) ALISO DB
- (I) LIMEKILN DB
- (I) WARD DB
- (III) STARFALL AND PINELAWN DB S
- (II) LA TUNA DB
- (III) BRACEMAR DB
- (III) BRACE DB
- (III) HAVEN WAY DB
- (III) IRVING DRIVE DB

- (III) SUNSET (UPPER) DB
- (III) SUNSET (LOWER) DB
- (I) DRY CANYON SOUTH FORK DB
- (III) ELMWOOD CYN DB
- (VI) CLOUDCROFT DB

- (II) BLUE GUM DB
- (VII) SADDLEBACK DB
- (II) DENIVELLE DB
- (II) PINELAWN DB
- (II) DUNSMUIR DB
- (II) WILSON DB
- (II) WILSON DB
- (II) WILSON DB

- (III) SUNSET (UPPER) DB
- (III) SUNSET (LOWER) DB
- (III) SUNSET (UPPER) DB
- (III) SUNSET (LOWER) DB
- (III) SUNSET (UPPER) DB
- (III) SUNSET (LOWER) DB
- (III) SUNSET (UPPER) DB
- (III) SUNSET (LOWER) DB

- (VI) SULLIVAN DB
- (III) SUNSET CANYON-DEER DB
- (III) EAGLE DB
- (III) CHILDS DB
- (III) BRAND DB
- (III) HILLCREST DB
- (II) SHIELDS DB
- (III) NICHOLS DB
- (IV) LAS FLORES DB
- (III) VERDUGO DB

- (III) GOLF CLUB DRIVE DB
- (III) MOUNTBATTEN DB
- (III) LINDA VISTA DB
- (III) SCHOLL DB
- (III) ARBOR DELL DB
- (III) RUBIO DB
- (III) INVERNESS DB
- (III) CHAMBERLAIN DB
- (III) OAKMONT VIEW DB

- (IV) BAILEY DB
- (IV) SUNNYSIDE DB
- (IV) CARRIAGE HOUSE DB
- (IV) SIERRA MADRE VILLA DB
- (IV) KINNEOLA WEST DB AND (IV) KINNEOLA EAST DB
- (II) COULD DB
- (II) HALLS DB
- (II) SNOWER DB
- (II) OAK DB
- (II) COOKS AND COOKS N-1A DB
- (II) BLANCHARD DB
- (II) ACTIAU DB
- (II) WILSON DB
- (II) WILSON DB
- (II) WILSON DB

- (IV) LINCOLN DB
- (IV) HAY DB
- (IV) MILLILLY DB
- (IV) PICKENS DB
- (IV) UPPER SHIELDS DB
- (IV) WEST RAYME DB
- (IV) FERN DB
- (IV) FAIR OAKS DB
- (IV) DEVENWOOD DB

- (IV) BAILEY DB
- (IV) SUNNYSIDE DB
- (IV) CARRIAGE HOUSE DB
- (IV) SIERRA MADRE VILLA DB
- (IV) KINNEOLA WEST DB AND (IV) KINNEOLA EAST DB
- (IV) BAILEY DB
- (IV) SUNNYSIDE DB
- (IV) CARRIAGE HOUSE DB
- (IV) SIERRA MADRE VILLA DB
- (IV) KINNEOLA WEST DB AND (IV) KINNEOLA EAST DB

- (III) RUBIO DB
- (III) INVERNESS DB
- (III) CHAMBERLAIN DB
- (III) OAKMONT VIEW DB

- (IV) AUBURN DB
- (IV) CARTER DB
- (IV) SIERRA MADRE DAM
- (IV) STURTEVANT DB
- (IV) LANNAN DB
- (IV) SANTA ANITA DB
- (IV) RUBY LOWER DB
- (IV) OAKGLADE DB
- (V) MADDOCK DB
- (V) CRESTVIEW DB
- (V) LAS LOMAS DB
- (V) HOOK WEST DB
- (V) WESTRIDGE DB
- (V) HARROW DB
- (V) ENGLEWILD DB
- (V) LITTLE DALTON DB
- (V) BIG DALTON DB
- (V) GORDON DB
- (V) MULL DB

- (IV) BAILEY DB
- (IV) SUNNYSIDE DB
- (IV) CARRIAGE HOUSE DB
- (IV) SIERRA MADRE VILLA DB
- (IV) KINNEOLA WEST DB AND (IV) KINNEOLA EAST DB
- (IV) BAILEY DB
- (IV) SUNNYSIDE DB
- (IV) CARRIAGE HOUSE DB
- (IV) SIERRA MADRE VILLA DB
- (IV) KINNEOLA WEST DB AND (IV) KINNEOLA EAST DB

- (IV) BAILEY DB
- (IV) SUNNYSIDE DB
- (IV) CARRIAGE HOUSE DB
- (IV) SIERRA MADRE VILLA DB
- (IV) KINNEOLA WEST DB AND (IV) KINNEOLA EAST DB
- (IV) BAILEY DB
- (IV) SUNNYSIDE DB
- (IV) CARRIAGE HOUSE DB
- (IV) SIERRA MADRE VILLA DB
- (IV) KINNEOLA WEST DB AND (IV) KINNEOLA EAST DB

- (IV) EMERALD EAST AND WEST DB S
- (V) MONUMENT DB
- (V) FIELDBROOK DB
- (V) TURNBULL DB



# LOS ANGELES COUNTY DEPARTMENT OF PUBLIC WORKS

## DEBRIS BASIN - DESIGN DATA

Including 1994-1995 Storm Season

### DATA SHEET A

Compiled by: Hydraulic and Water Conservation

Division - Sedimentation Management

Date: December 14, 1995

FILE: DSA95.XLS

DEBRIS BASIN	FIRST DEBRIS SEASON	UNCONTROLLED DRAINAGE AREA ABOVE BASIN (SQ. MI.)	BOTTOM ELEV. AT MAX CAP. (FT.)	ELEVATION PORT INVERT (FT.)	ELEVATION SPILLWAY CREST (FT.)	WIDTH SPILLWAY (FT.)	ELEVATION CREST OF DAM (FT.)	MAXIMUM DEBRIS CAPACITY (CU. YDS.)
Aliso	1970 - 71	2.77	1,108.0	1,108.4	1,120.0	70.0	1,134.0	41,700 (8)
Arbor Dell	1971 - 72	0.11	898.7	898.4	913.0	22.9	919.6	12,400
Auburn	1954 - 55	0.19	1,264.0 (15)	1,260.5 (15)	1,278.1 (15)	30.0 (15)	1,286.0 (15)	37,700 (15)
Bailey	1945 - 46	0.60	1,123.0	1,123.1	1,155.0	30.0	1,166.0	128,800
Beatty	1970 - 71	0.27	800.0	800.0	807.0	32.0	815.5	43,000
Bigbriar	1971 - 72	0.02	1,898.3	1,896.0	1,910.0	14.0	1,910.8	2,600
Big Dalton	1959 - 60	2.94	1,102.0	1,101.9 (3)	1,131.5	116.0	1,148.7	517,800
Blanchard	1968 - 69	0.47	2,026.0	2,026.0	2,053.5	40.0	2,065.0	74,500
Blue Gum	1968 - 69	0.19	2,020.0	2,020.0	2,042.0	25.0	2,053.0	39,600
Brace	1971 - 72	0.29	1,189.7	1,189.7	1,196.0	20.0	1,203.3	30,000 (15)
Bracemar	1971 - 72	0.01	1,140.0	1,140.0	1,145.5	8.0	1,148.0	700 (14)
Bradbury	1954 - 55	0.68	912.5	913.1	920.0	58.0	928.0	89,800
Brand	1935 - 36	1.04	860.0	860.0	890.0	60.0	903.0	166,000
Buena Vista	1985 - 86	0.10	978.7	978.7	992.2	39.0	997.7	21,800
Carriage House	1970 - 71	0.03	1,350.2	1,350.0	1,362.9	15.0	1,366.8	6,100
Carter	1954 - 55	0.12	1,222.0	1,223.2	1,238.2	30.0	1,245.0	14,500
Cassara	1976 - 77	0.21	1,271.5	1,271.5	1,291.7	66.0	1,295.4	36,700
Chamberlain	1974 - 75	0.04	1,084.6	1,084.0	1,097.5	20.0	1,101.3	4,700
Childs	1963 - 64	0.30	1,022.0	1,022.0	1,058.8	23.0	1,071.0	50,400
Cloud Creek	1972 - 73	0.01	2,350.5	2,350.5	2,360.0	(5)	2,362.0	5,100
Cloudcroft	1973 - 74	0.21	313.9	315.0	329.5	36.0	329.5	34,700
Cooks	1951 - 52	0.58	2,058.0	2,058.0	2,082.9	48.0	2,092.0	51,900
Cooks M-1A	1975 - 76	(13)	2,120.0	(10)	2,142.4	(10)	(10)	33,700
Crestview	1983 - 84	0.03	864.4	864.0	886.2	20.0	891.7	5,900 (14)
Crocker	1983 - 84	0.67	1,064.2	1,064.2	1,069.8	36.0	1,077.0	19,300 (14)
Deer	1954 - 55	0.59	1,185.4	1,185.0	1,201.0	56.0	1,209.6	56,600
Denivelle	1976 - 77	0.18	1,471.0	1,471.0	1,479.3	46.0	1,483.3	8,200
Devonwood	1981 - 82	0.03	1,899.0 (15)	1,899.0 (15)	1,921.8 (15)	(16)	1,927.5 (15)	10,400 (15)
Dry Canyon-South Fork	1978 - 79	0.49	1,062.8	1,062.5	1,074.8	32.0	1,079.3	7,900
Dunsmuir	1935 - 36	0.84	2,228.0	2,227.7	2,257.2	60.0	2,272.2	102,700
Eagle	1936 - 37	0.48	1,849.5	1,845.5	1,880.2	60.0	1,895.2	63,100
Elmwood	1964 - 65	0.31	912.0	911.5	938.0	22.0	952.0	66,400
Emerald-East	1964 - 65	0.32	1,184.7	1,181.1	1,192.0	30.0	1,204.0	13,600
Englewild	1961 - 62	0.44	1,274.9	1,275.0	1,297.0	50.0	1,300.0	40,600
Fair Oaks	1935 - 36	0.21	1,544.0	1,544.0	1,561.9	(6)	1,566.5	23,800
Fern	1935 - 36	0.31	1,440.0	1,440.0	1,476.0	25.0	1,482.0	43,200 (15)
Fieldbrook	1974 - 75	0.35	712.7	713.0	718.0	28.0	722.3	2,800
Golf Club Drive	1970 - 71	0.99	880.7	880.7	902.0	36.7	915.0	14,700

# LOS ANGELES COUNTY DEPARTMENT OF PUBLIC WORKS

## DEBRIS BASIN - DESIGN DATA

Including 1994-1995 Storm Season

DATA SHEET A

Compiled by: Hydraulic and Water Conservation

Division - Sedimentation Management

Date: December 14, 1995

FILE: DSA95.XLS

DEBRIS BASIN	FIRST DEBRIS SEASON	UNCONTROLLED DRAINAGE AREA ABOVE BASIN (SQ. MI.)	BOTTOM ELEV. AT MAX CAP. (FT.)	ELEVATION PORT INVERT (FT.)	ELEVATION SPILLWAY CREST (FT.)	WIDTH SPILLWAY (FT.)	ELEVATION CREST OF DAM (FT.)	MAXIMUM DEBRIS CAPACITY (CU. YDS.)
Gordon	1973 - 74	0.18	1075.7	1,075.0	1,096.0	22.0	1,104.5	33,100 (15)
Gould	1947 - 48	0.36	1,529.5	1,528.2	1,548.0	55.0	1,558.3	52,800
Gould (Upper)	1976 - 77	0.18	1,863.9	1,863.9	1,897.7	32.0	1,901.0	52,300
Halls	1935 - 36	0.86	1,641.6	1,641.8	1,661.3	131.0	1,664.0	89,400
Harrow	1958 - 59	0.43	1,254.8	1,255.0	1,269.0	40.0	1,277.8	68,000
Haven Way	1991 - 92	0.13	1,323.0	1,323.0	1,329.0	20.0	1,335.6	38,200
Hay	1936 - 37	0.20	1,890.2	1,890.2	1,908.0	36.0	1,915.0	36,700
Hillcrest	1962 - 63	0.35	863.5	863.5	885.0	18.0	901.0	57,800
Hog	1969 - 70	0.32	1,520.0 (18)	1,520.0	1,535.0	32.0	1,547.0	42,500 (18)
Hook East	1968 - 69	0.18	1,197.5	1,198.0	1,210.9	37.0	1,215.0	22,300
Hook West	1970 - 71	0.17	1,144.8	1,145.0	1,158.9	40.0	1,167.0	21,600
Inverness	1982 - 83	0.03	1,253.0	1,252.9	1,256.7	20.0	1,261.0	3,300
Irving Drive	1974 - 75	0.03	905.8	905.0	915.3	12.0	920.0	1,200
Kinneloa (17)	1964 - 65	0.20	1,370.0 (15)	1,370.0 (15)	1,403.4 (15)	76.0 (15)	1,407.9 (15)	35,800 (15)
Kinneloa - West (17)	1966 - 67	0.19	1,384.9 (15)	1,385.0 (15)	1,412.7 (15)	22.0 (15)	1,421.0 (15)	35,000 (15)
Lannan	1954 - 55	0.25	1,016.0	1,015.0	1,035.8	14.0	1,043.0	41,400
La Tuna	1955 - 56	5.34	1,109.0	1,110.0	1,140.0	75.0	1,157.0	495,300
Las Flores	1935 - 36	0.45	1,685.1	(9)	1,715.6	50.0	1,726.4	55,600
Las Lomas	1983 - 84	0.07	887.0	887.0	906.0	77.0	908.5	17,900 (15)
Limekiln	1963 - 64	3.72	992.0	992.0	1,003.0	77.0	1,019.0	171,600
Lincoln	1935 - 36	0.50	1,275.8	1,276.0	1,304.0	56.0	1,322.5	38,400
Linda Vista	1970 - 71	0.37	979.5	979.5	989.8	40.0	995.7	3,200
Little Dalton	1959 - 60	3.31	1,140.0	1,139.5	1,186.0	84.0	1,200.2	660,500
Maddock	1954 - 55	0.26	888.6	891.8	901.0	36.0	904.0	45,000
Marston/Paragon	1988 - 89	0.20	1,455.6	1,455.6	1,460.0	20.0	1,466.0	6,000
May No. 1	1953 - 54	0.70	1,666.0	1,666.0	1,684.0	60.0	1,692.5	64,000
May No. 2	1953 - 54	0.09	1,663.4	1,663.5 (2)	1,669.5	20.0	1,674.0	13,400
Monument	1981 - 82	0.11	943.8	942.3	950.0	12.0	954.0	6,800
Morgan	1964 - 65	0.60	1,135.0	1,135.0	1,161.9	45.0	1,171.5	76,800 (15)
Mountbatten	1983 - 84	0.01	1,136.2	1,135.5	1,140.9	20.0	1,141.0	1,400
Mull	1973 - 74	0.15	1,146.9	1,147.0	1,154.0	20.0	1,165.0	12,500
Mullally (11)	1974 - 75	0.34	2,420.0	2,420.0	2,435.4	42.0	2,439.6	9,400
Nichols	1937 - 38	0.94	480.5	481.0	485.1	50.0	495.0	14,100
Oak	1975 - 76	0.05	2,145.4	2,145.7	2,151.8	50.0	2,156.2	12,000 (15)
Oakglade	1974 - 75	0.06	1,274.6	1,280.0	1,290.0	20.0	1,296.0	7,250
Oakmont View Drive	1984 - 85	0.02	1,315.5	1,315.5	1,327.5	20.0	1,328.5	3,400
Oliver	1989 - 90	0.18	1,258.0	1,258.0	1,278.3	41.0	1,283.3	32,100
Pickens	1935 - 36	1.50	1,563.6	1,564.0	1,600.0	123.0	1,613.0	125,100

# LOS ANGELES COUNTY DEPARTMENT OF PUBLIC WORKS

## DEBRIS BASIN - DESIGN DATA

Including 1994-1995 Storm Season

DATA SHEET A

Compiled by: Hydraulic and Water Conservation

Division - Sedimentation Management

Date: December 14, 1995

FILE: DSA95.XLS

DEBRIS BASIN	FIRST DEBRIS SEASON	UNCONTROLLED DRAINAGE AREA ABOVE BASIN (SQ. MI.)	BOTTOM ELEV. AT MAX CAP. (FT.)	ELEVATION PORT INVERT (FT.)	ELEVATION SPILLWAY CREST (FT.)	WIDTH SPILLWAY (FT.)	ELEVATION CREST OF DAM (FT.)	MAXIMUM DEBRIS CAPACITY (CU. YDS.)
Pinelawn	1973 - 74	0.02	2,431.0	2,430.5	2,443.0	(7)	2,448.5	3,200
Rowley	1953 - 54	0.21	1,703.6	1,703.6	1,714.0	60.0	1,722.0	43,100
Rowley (Upper)	1976 - 77	0.31	1,926.0	1,926.0	1,946.0	42.0	1,951.3	28,800
Rubio	1943 - 44	1.26	1,582.1	1,582.1	1,608.3	59.0	1,625.5	127,200
Ruby (Lower)	1955 - 56	0.28	810.8	809.6	828.0	45.0	833.0	28,600
Rye	1981 - 82	1.11	1,073.9	1,073.8	1,077.7	58.2	1,081.5	19,100
Saddleback	1988 - 89	0.04	1,779.0	1,779.3	1,790.0	(10)	1,796.0	27,000
Santa Anita	1959 - 60	1.70	748.5	748.5 (3)	774.7	160.0	796.0	394,600
Sawpit	1954 - 55	2.82	930.3	930.3	982.0	110.0	1,000.0	635,700
Scholl	1945 - 46	0.16	950.0	950.0 (2)	956.0	76.0	966.0	9,300
Schoolhouse	1962 - 63	0.28	1,459.6	1,460.0	1,478.5	20.0	1,491.0	67,700
Schwartz	1976 - 77	0.25	1,294.7	1,294.7	1,313.2	35.0	1,319.0	45,400
Shields	1937 - 38	0.06	2,030.0	2,050.0	2,058.1	30.0	2,070.2	34,800
Sierra Madre Dam (12)	1927 - 28	2.39	1,119.6	1,119.5	1,172.5	62.5	1,175.0	136,400
Sierra Madre Villa	1957 - 58	1.46	1,069.2	1,069.2	1,088.9	48.0	1,102.5	402,300
Snover	1936 - 37	0.21	1,862.8	1,862.7	1,879.0	40.0	1,893.7	24,800
Sombrero	1969 - 70	1.06	1,539.6	1,540.0	1,564.8	45.0	1,580.0	87,900
Spinks	1958 - 59	0.44	750.0	750.0	761.5	40.0	765.9	56,000
Starfall	1973 - 74	0.13	2,428.0	2,428.0	2,441.5	30.0	2,446.5	14,900
Stetson	1969 - 70	0.29	1,556.0	1,555.0	1,570.0	32.0	1,579.0	41,300
Stough	1940 - 41	1.65	1,006.0	1,005.8	1,031.5 (4)	100.0	1,043.5	180,600
Sturtevant	1967 - 68	0.03	975.0	971.0	983.6	8.0	990.0	1,400
Sullivan	1970 - 71	2.38	570.0	570.0	587.0	50.0	599.3	51,000
Sunnyside	1970 - 71	0.02	1,290.0	1,290.0	1,299.5	15.0	1,303.8	3,400
Sunset Canyon-Deer	1982 - 83	0.21	1,382.4	1,380.5	1,401.8	24.0	1,409.1	5,000
Sunset (Lower)	1963 - 64	0.45	1,003.8	994.5	1,040.0	40.0	1,056.0	158,900
Sunset (Upper)	1928 - 29	0.44	1,574.2	1,574.0	1,603.7	75.0	1,610.1	15,900
Turnbull	1952 - 53	0.99	476.1	475.6	492.0	40.0	503.0	21,600
Upper Shields	1976 - 77	0.21	2,498.0	2,498.0	2,530.0	33.3	2,536.0	35,400
Verdugo	1935 - 36	9.40	1,109.5	1,110.0	1,119.7	145.0	1,131.0	131,000
Ward	1956 - 57	0.12	2,021.8	2,022.0	2,043.0	58.0	2,035.3	26,400
West Ravine	1935 - 36	0.25	1,468.8	1,469.6 (1)	1,501.9	20.0	1,505.5	44,900
Westridge	1974 - 75	0.02	894.0	894.0	901.0	10.7	906.0	1,400 (14)
Wildwood	1967 - 68	0.65	1,342.9	1,342.9	1,354.0	50.0	1,360.0	20,700
William S. Hart Park	1983 - 84	0.09	1,282.5	1,280.0	1,290.0	19.0	1,293.0	2,400
Wilson	1962 - 63	2.58	1,493.0	1,493.0	1,526.0	60.0	1,543.0	313,100
Winery	1968 - 69	0.18	1,920.0	1,920.0	1,935.0	20.0	1,945.0	29,200
Zachau	1956 - 57	0.35	1,803.4	1,803.1	1,820.5	44.0	1,823.0	47,900

# LOS ANGELES COUNTY DEPARTMENT OF PUBLIC WORKS

## DEBRIS BASIN - DESIGN DATA

Including 1994-1995 Storm Season

DATA SHEET A

Compiled by: Hydraulic and Water Conservation

Division - Sedimentation Management

Date: December 14, 1995

FILE: DSA95.XLS

DEBRIS BASIN	FIRST DEBRIS SEASON	UNCONTROLLED DRAINAGE AREA ABOVE BASIN (SQ. MI.)	BOTTOM ELEV. AT MAX CAP. (FT.)	ELEVATION PORT INVERT (FT.)	ELEVATION SPILLWAY CREST (FT.)	WIDTH SPILLWAY (FT.)	ELEVATION CREST OF DAM (FT.)	MAXIMUM DEBRIS CAPACITY (CU. YDS.)
<b>114 DEBRIS BASINS</b>		<b>61.95</b>						<b>7,744,850</b>

# LOS ANGELES COUNTY DEPARTMENT OF PUBLIC WORKS

## DEBRIS BASIN-DESIGN DATA Including 1994-95 Storm Season

### DATA SHEET A

Compiled by: Hydraulic and Water Conservation Division  
Sedimentation Management Unit

Date: December 14, 1995

File: DSAR95.WPD

### FOOTNOTES

- (1) Lowest clear water outlet, not spillway.
- (2) Elevation of spillway notch.
- (3) Flow line of sluiceway.
- (4) Elevation of spillway into outlet channel. Elevation of overflow spillway 1,036.9 feet.
- (5) One 30-inch reinforced concrete pipe.
- (6) Four 36-inch corrugated metal pipes.
- (7) One 36-inch reinforced concrete pipe. (Elevated inlet)
- (8) Debris capacity available within right of way limits.
- (9) Pit-type basin.
- (10) Information unavailable.
- (11) Special cleanout required due to limited storage.
- (12) Cleanout required when debris reaches or exceeds elevation 1128.9 feet against face of dam.
- (13) Values are combined with Cooks debris basin.
- (14) Spillway level storage capacity.
- (15) Data taken from design drawings used for enlarging the basin capacity.
- (16) 7 feet in diameter circular outlet type.
- (17) The debris basin is currently under construction for storage capacity enlargement.
- (18) Revised data taken from new approved cut plan drawing number 282A-D5.1-5.3



# LOS ANGELES COUNTY DEPARTMENT OF PUBLIC WORKS

## DEBRIS BASIN-DEBRIS PRODUCTION HISTORY Including 1994 -1995 Storm Season

DATA SHEET B

Compiled by: Hydraulic and Water Conservation  
Division - Sedimentation Management  
Date: December 14, 1995  
File: DSB95.XLW

DEBRIS BASIN	DPA ZONE	NUMBER OF SEASONS	TOTAL DEBRIS DEPOSITED (CU. YDS.) (1)	AVERAGE ANNUAL DEBRIS PRODUCTION (CU.YDS./YR)	MAXIMUM SEASONAL DEBRIS PRODUCTION		DEBRIS STORED CU. YDS.	ESTIMATED CONDITIONS	
					CU. YDS.	SEASON		CU. YDS.	PERCENT
Aliso	4	25	243,717	9,749	52,206	1994-95	0	41,700	100 (5)
Arbor Dell	2	24	1,481	62	800	1979-80	500	11,900	96
Auburn (9)	1	41	104,406	2,546	20,100	1961-62	0	37,700 (11)	100 (11)
Bailey (9)	1	50	291,811	5,836	91,000	1979-80	0	128,800	100
Beatty	1	25	14,061	562	7,600	1979-80	4,000	39,000	91
Bigbriar	1	24	4,140	173	866	1992-93	0	2,600	100
Big Dalton	1	36	859,003	23,861	296,700	1968-69	31,200	486,600	94
Blanchard	1	27	78,368	2,903	36,600	1977-78	1,557	72,943	98
Blue Gum	1	27	41,619	1,541	19,100	1977-78	360	39,240	99
Brace	2	24	41,755	1,740	12,000	1977-78	2,200	27,800 (11)	93 (11)
Bracemar	2	24	671	28	283	1980-81	200	500 (15)	71 (15)
Bradbury	1	41	274,144	6,686	70,200	1968-69	7,983	81,817	91
Brand	1	60	276,813	4,614	53,100	1977-78	6,100	159,900	96
Buena Vista	1	10	440	44	400	1992-93	0	21,800	100
Carriage House (9)	1	25	7,846	314	3,400	1979-80	0	6,100	100
Carter (9)	1	41	42,831	1,045	12,600	1979-80	0	14,500	100
Cassara	1	19	29,687	1,562	16,800	1977-78	2,500	34,200	93
Chamberlain (9)	2	21	910	43	300	1974-75	-136	4,836	103
Childs	1	32	46,518	1,454	10,700	1980-81	1,500	48,900	97
Cloud Creek	1	23	4,232	184	1,800	1977-78	300	4,800	94
Cloudcroft	4	22	13,992	636	6,100	1973-74	3,070	31,630	91
Cooks	1	44	174,821 (3)	3,973 (3)	61,200 (3)	1977-78	1,800 (3)	83,800 (3)	98 (3)
Cooks M-1A	1	20	(8)	(8)	(8)	(8)	(8)	(8)	(8)
Crestview	1	12	(6)	(6)	(6)	(6)	0	5,900 (15)	100 (15)
Crocker	8	12	13,316	1,110	5,745	1991-92	4,950 (14)	14,350 (15)	74 (14,15)
Deer	1	41	171,511	4,183	44,200	1968-69	4,200	52,400	93
Denivelle	2	19	9,837	518	5,500	1977-78	560	7,640	93
Devonwood (9)	1	14	6,584	470	5,800	1993-94	0	10,400 (11)	100 (11)
Dry Canyon-South Fork	4	17	8,968	528	5,300	1979-80	480	7,420	94
Dunsmuir	1	60	380,728	6,345	86,200	1977-78	4,800	97,900	95
Eagle	1	59	200,078 (13)	3,391	41,700	1937-38	6,147	56,953	90
Elmwood	1	31	56,061	1,808	16,100	1980-81	2,650	63,750	96
Emerald-East	2	31	13,054	421	1,800	1985-86	2,538	11,062	81
Englewild	1	34	87,450 (2)	2,572	60,200 (2)	1968-69	2,380	38,220	94
Fair Oaks (9)	1	60	116,240	1,937	15,700	1935-36	0	23,800	100
Fern (9)	1	60	188,352	3,139	23,900	1968-69	0	43,200 (11)	100 (11)
Fieldbrook	6	21	2,254	107	500	1991-92	0	2,800	100
Golf Club Drive	2	25	34,893	1,396	11,600	1979-80	0	14,700	100
Gordon	1	22	5,604	255	3,800	1977-78	0	33,100 (11)	100 (11)

LOS ANGELES COUNTY DEPARTMENT OF PUBLIC WORKS

DEBRIS BASIN-DEBRIS PRODUCTION HISTORY  
Including 1994 -1995 Storm Season

DATA SHEET B

Compiled by: Hydraulic and Water Conservation  
Division - Sedimentation Management  
Date: December 14, 1995  
File: DSB95.XLW

DEBRIS BASIN	DPA ZONE	NUMBER OF SEASONS	TOTAL DEBRIS DEPOSITED (CU. YDS.) (1)	AVERAGE ANNUAL DEBRIS PRODUCTION (CU.YDS./YR)	MAXIMUM SEASONAL DEBRIS PRODUCTION		ESTIMATED CONDITIONS		
					CU. YDS.	SEASON	DEBRIS STORED CU. YDS.	CAPACITY AVAILABLE CU. YDS.	PERCENT
Gould	1	48	122,273 (13)	2,547	18,000	1965-66	1,389	51,411	97
Gould (Upper)	1	19	39,179	2,062	11,177	1991-92	3,666	48,634	93
Halls	1	60	612,877	10,215	102,100	1937-38	6,700	82,700	93
Harrow	1	37	78,347 (2)	2,117	63,400 (2)	1968-69	-5,511	73,511	108
Haven Way	2	4	(6)	(6)	(6)	(6)	0	38,200	100
Hay	1	59	74,352 (13)	1,260	18,200	1937-38	740	35,960	98
Hillcrest	1	33	52,649	1,595	11,700	1964-65	4,450	53,350	92
Hog	1	26	10,534	405	3,900	1977-78	6,600 (16)	35,900 (16)	84 (16)
Hook East	1	27	46,609 (2)	1,726	40,200 (2)	1968-69	0	22,300	100
Hook West	1	25	7,268	291	3,600	1979-80	430	21,170	98
Inverness	2	13	498	38	252	1982-83	700	2,600	79
Irving Drive	2	21	1,746	83	600	1980-81	0	1,200	100
Kinneloa (9,12)	1	31	108,102 (2)	3,487	36,366	1993-94	0	35,800 (11,12)	100 (11)
Kinneloa West (9,12)	1	29	141,622 (2)	4,884	34,754	1993-94	0	35,000 (11,12)	100 (11)
Lannan	1	41	84,767	2,067	18,200	1969-70	700	40,700	98
La Tuna	2	40	652,523	16,313	172,100	1977-78	59,164	436,136	88
Las Flores (9)	1	60	239,060	3,984	36,000	1937-38	0	55,600	100
Las Lomas	1	12	615	51	(6)	(6)	0	17,900 (11)	100 (11)
Limekiln	4	32	348,858	10,902	42,300	1965-66	0	171,600	100
Lincoln (9)	1	60	139,793	2,330	28,400	1968-69	0	38,400	100
Linda Vista	2	25	14,389	576	3,400	1977-78	0	3,200	100
Little Dalton	1	36	928,373 (13)	25,788	337,800	1968-69	39,240	621,260	94
Maddock	1	41	57,134	1,394	16,200	1980-81	2,200	42,800	95
Marston/Paragon	5	7	130	19	(6)	(6)	270	5,730	96
May No. 1 (9)	2	42	233,384 (13)	5,557	45,800	1968-69	0	64,000	100
May No. 2	2	42	28,016	667	6,200	1966-67	0	13,400	100
Monument	6	14	2,767 (13)	198	2,600	1981-82	0	6,800	100
Morgan	1	31	30,841	995	12,900	1968-69	0	76,800 (11)	100 (11)
Mountbatten	1	12	110	9	(6)	(6)	40	1,360	97
Mull	1	22	2,426	110	1,100	1979-80	532	11,968	96
Mullally (9)	1	21	65,706 (4)	3,129	24,400 (4)	1977-78	0	9,400	100
Nichols	4	58	131,334	2,264	21,800	1951-52	30	14,070	100
Oak	1	20	13,267	663	6,900	1977-78	0	12,000 (11)	100 (11)
Oakglade	1	21	1,657	79	1,200	1977-78	740	6,510	90
Oakmont View Drive	1	11	621	56	221	1991-92	55	3,345	98
Oliver	1	6	31,980 (7)	5,330	16,255 (7)	1977-78	1,600	30,500	95
Pickens	1	60	731,007	12,183	140,600	1977-78	1,900	123,200	98
Pinelawn	1	22	5,509	250	1,200	1976-77	330	2,870	90
Rowley	1&7	42	79,235 (4)	1,887	13,000 (4)	1977-78	3,000	40,100	93

# LOS ANGELES COUNTY DEPARTMENT OF PUBLIC WORKS

## DEBRIS BASIN-DEBRIS PRODUCTION HISTORY Including 1994 -1995 Storm Season

DATA SHEET B

Compiled by: Hydraulic and Water Conservation  
Division - Sedimentation Management  
Date: December 14, 1995  
File: DSB95.XLW

DEBRIS BASIN	DPA ZONE	NUMBER OF SEASONS	TOTAL DEBRIS DEPOSITED (CU. YDS.) (1)	AVERAGE ANNUAL DEBRIS PRODUCTION (CU.YDS./YR)	MAXIMUM SEASONAL DEBRIS PRODUCTION		ESTIMATED CONDITIONS		
					CU. YDS.	SEASON	DEBRIS STORED CU. YDS.	CAPACITY AVAILABLE CU. YDS.	PERCENT
Rowley (Upper)	1	19	51,805 (4)	2,727	31,900 (4)	1977-78	-574	29,374	102
Rubio (9)	1	52	345,798	6,650	133,000	1979-80	0	127,200	100
Ruby (Lower)	1	40	21,032 (13)	526	8,300	1968-69	1,600	27,000	94
Rye	5	14	17,704	1,265	10,000	1981-82	1,200	17,900	94
Saddleback	1	7	2,960	423	(6)	(6)	2,960	24,040	89
Santa Anita	1	36	755,383 (2,3)	20,983	132,000 (2,3)	1961-62	-3,334	397,934	101
Sawpit	1	41	700,497 (2,3,13)	17,085	232,200 (2,3)	1968-69	13,500	622,200	98
Scholl	2	50	20,072	401	800	1968-69	50	9,250	99
Schoolhouse	1	33	34,491	1,045	21,600	1962-63	5,226	62,474	92
Schwartz	1	19	49,859	2,624	21,600	1977-78	4,800	40,600	89
Shields	1	58	133,930 (3,13)	2,309	7,800	1937-38	1,810	32,990	95
Sierra Madre Dam(9&10)	1	68	374,822 (2)	5,512	95,200 (2)	1968-69	0	136,400	100
Sierra Madre Villa (9)	1	38	774,422	20,380	171,775	1993-94	0	402,300	100
Snover	1	59	109,960	1,864	19,300	1938-39	480	24,320	98
Sombrero	1	26	14,355	552	3,300	1977-78	8,500	79,400	90
Spinks	1	37	68,322	1,847	15,600	1968-69	1,936	54,064	97
Starfall	1	22	29,123	1,324	14,200	1977-78	1,950	12,950	87
Stetson (9)	1	26	22,052	848	1,500	1977-78	700	40,600	98
Stough	2	55	162,119 (13)	2,948	44,100	1964-65	2,800	177,800	98
Sturtevant	1	28	1,378	49	500	1977-78	177	1,223	87
Sullivan	4	25	123,752	4,950	35,300	1979-80	29,800 (14)	21,200	42 (14)
Sunnyside (9)	1	25	4,164	167	1,621	1993-94	0	3,400	100
Sunset Canyon-Deer	1	13	4,192	322	3,400	1982-83	217	4,783	96
Sunset (Lower)	1	32	143,580 (13)	4,487	20,200	1980-81	3,700	155,200	98
Sunset (Upper)	1	67	149,680	2,234	27,000	1964-65	-1,470	17,370	109
Turnbull	6	43	72,492 (2)	1,686	15,900 (2)	1968-69	0	21,600	100
Upper Shields	1	19	43,247 (4,7)	2,276	16,900 (4,7)	1977-78	30	35,370	100
Verdugo	1	60	827,992	13,800	105,400	1937-38	13,334	117,666	90
Ward	1	39	52,671	1,351	17,800	1977-78	1,233	25,167	95
West Ravine (9)	1	60	172,444 (13)	2,874	29,900	1937-38	0	44,900	100
Westridge	1&7	21	294	14	(6)	(6)	281	1,119 (15)	80 (15)
Wildwood	3&5	28	91,812	3,279	16,700	1977-78	0	20,700	100
William S. Hart Park	5	12	755	63	600	1983-84	0	2,400	100
Wilson	2	33	216,134	6,550	55,500	1968-69	15,171	297,929	95
Winery	1	27	27,215	1,008	9,400	1968-69	0	29,200	100
Zachau	1	39	111,181 (4,13)	2,851	48,100 (4)	1977-78	2,950	44,950	94
<b>114 DEBRIS BASINS</b>			<b>14,699,429</b>	<b>364,501</b>			<b>329,823</b>	<b>7,415,011</b>	

# LOS ANGELES COUNTY DEPARTMENT OF PUBLIC WORKS

## DEBRIS BASIN - DESIGN DATA

Including 1995-1996 Storm Season

DATA SHEET A

Compiled by: Hydraulic and Water Conservation Division  
Sedimentation Mana

Date: October 15, 1996

FILE: DSA96.XLS

DEBRIS BASIN	FIRST DEBRIS SEASON	UNCONTROLLED DRAINAGE AREA ABOVE BASIN (SQ. MI.)	BOTTOM ELEV. AT MAX CAP. (FT.)	ELEVATION PORT INVERT (FT.)	ELEVATION SPILLWAY CREST (FT.)	WIDTH SPILLWAY (FT.)	ELEVATION CREST OF DAM (FT.)	MAXIMUM DEBRIS CAPACITY (CU. YDS.)
Aliso	1970 - 71	2.77	1,108.0	1,108.4	1,120.0	70.0	1,134.0	41,700 (8)
Arbor Dell	1971 - 72	0.11	898.7	898.4	913.0	22.9	919.6	12,400
Auburn	1954 - 55	0.19	1,264.0 (15)	1,260.5 (15)	1,278.1 (15)	30.0 (15)	1,286.0 (15)	37,700 (15)
Bailey	1945 - 46	0.60	1,123.1	1,123.1	1,155.0	30.0	1,166.0	128,800
Beatty	1970 - 71	0.27	800.0	800.0	807.0	32.0	815.5	43,000
Bigbriar	1971 - 72	0.02	1,898.3	1,896.0	1,910.0	14.0	1,910.8	2,600
Big Dalton	1959 - 60	2.94	1,102.0	1,101.9 (3)	1,131.5	116.0	1,148.7	517,800
Blanchard	1968 - 69	0.47	2,026.0	2,026.0	2,053.5	40.0	2,065.0	74,500
Blue Gum	1968 - 69	0.19	2,020.0	2,020.0	2,042.0	25.0	2,053.0	39,600
Brace	1971 - 72	0.29	1,189.7	1,189.7	1,196.1	20.0	1,205.0	30,300
Bracemar	1971 - 72	0.01	1,140.0	1,140.0	1,145.5	8.0	1,148.0	700 (14)
Bradbury	1954 - 55	0.68	912.5	913.1	920.0	58.0	928.0	89,800
Brand	1935 - 36	1.04	860.0	860.0	890.0	60.0	903.0	166,000
Buena Vista	1985 - 86	0.10	978.7	978.7	992.2	39.0	997.7	21,800
Carriage House	1970 - 71	0.03	1,350.2	1,350.0	1,362.9	15.0	1,366.8	6,100
Carter	1954 - 55	0.12	1,222.0	1,223.2	1,238.2	30.0	1,245.0	14,500
Cassara	1976 - 77	0.21	1,271.5	1,271.5	1,291.7	66.0	1,295.4	36,700
Chamberlain	1974 - 75	0.04	1,084.6	1,084.0	1,097.5	20.0	1,101.3	4,700
Chandler	1995 - 96	0.16	1,055.0	1,052.0	1,073.0	36.0	1,078.3	20,300 (15)
Childs	1963 - 64	0.30	1,022.0	1,022.0	1,058.8	23.0	1,071.0	50,400
Cloud Creek	1972 - 73	0.01	2,350.5	2,350.5	2,360.0	(5)	2,362.0	5,100
Cloudcroft	1973 - 74	0.21	313.9	315.0	329.5	36.0	329.5	34,700
Cooks	1951 - 52	0.58	2,058.0	2,058.0	2,082.9	48.0	2,092.0	51,900
Cooks M-1A	1975 - 76	(13)	2,120.0	(10)	2,142.4	(10)	(10)	33,700
Crestview	1983 - 84	0.03	864.4	864.0	886.2	20.0	891.7	5,900 (14)
Crocker	1983 - 84	0.67	1,064.2	1,064.2	1,069.8	36.0	1,077.0	19,300 (14)
Deer	1954 - 55	0.59	1,185.4	1,185.0	1,201.0	56.0	1,209.6	56,600
Denivelle	1976 - 77	0.18	1,471.0	1,471.0	1,479.3	46.0	1,483.3	7,900
Devonwood	1981 - 82	0.03	1,898.9	1,899.0	1,921.7	(16)	1,927.5	10,800
Dry Canyon-South Fork	1978 - 79	0.49	1,062.8	1,062.5	1,074.8	32.0	1,079.3	7,900
Dunsmuir	1935 - 36	0.84	2,228.0	2,227.7	2,257.2	60.0	2,272.2	102,700
Eagle	1936 - 37	0.48	1,849.5	1,845.5	1,880.2	60.0	1,895.2	63,100
Elmwood	1964 - 65	0.31	912.0	911.5	938.0	22.0	952.0	61,100
Emerald-East	1964 - 65	0.32	1,184.7	1,181.1	1,192.0	30.0	1,204.0	13,600
Englewild	1961 - 62	0.44	1,274.9	1,275.0	1,297.0	50.0	1,300.0	40,600
Fair Oaks	1935 - 36	0.21	1,544.0	1,544.0	1,561.9	(6)	1,566.5	23,800
Fern	1935 - 36	0.31	1,440.0	1,440.0	1,476.0	25.0	1,482.0	43,200 (15)
Fieldbrook	1974 - 75	0.35	712.7	713.0	718.0	28.0	722.3	2,800

# LOS ANGELES COUNTY DEPARTMENT OF PUBLIC WORKS

## DEBRIS BASIN - DESIGN DATA

Including 1995-1996 Storm Season

DATA SHEET A

Compiled by: Hydraulic and Water Conservation Division  
Sedimentation Mana

Date: October 15, 1996

FILE: DSA96.XLS

DEBRIS BASIN	FIRST DEBRIS SEASON	UNCONTROLLED DRAINAGE AREA ABOVE BASIN (SQ. MI.)	BOTTOM ELEV. AT MAX CAP. (FT.)	ELEVATION PORT INVERT (FT.)	ELEVATION SPILLWAY CREST (FT.)	WIDTH SPILLWAY (FT.)	ELEVATION CREST OF DAM (FT.)	MAXIMUM DEBRIS CAPACITY (CU. YDS.)
Golf Club Drive	1970 - 71	0.97	880.7	880.7	902.0	36.7	915.0	14,700
Gordon	1973 - 74	0.18	1075.7	1,075.0	1,096.0	22.0	1,104.5	32,600
Gould	1947 - 48	0.36	1,529.5	1,528.2	1,548.0	55.0	1,558.3	52,800
Gould (Upper)	1976 - 77	0.18	1,863.9	1,863.9	1,897.7	32.0	1,901.0	52,300
Halls	1935 - 36	0.83	1,641.6	1,641.8	1,661.3	131.0	1,664.0	89,400
Harrow	1958 - 59	0.43	1,254.8	1,255.0	1,269.0	40.0	1,277.8	68,000
Haven Way	1991 - 92	0.13	1,323.0	1,323.0	1,329.0	20.0	1,335.6	38,200
Hay	1936 - 37	0.20	1,890.2	1,890.2	1,908.0	36.0	1,915.0	36,700
Hillcrest	1962 - 63	0.35	863.5	863.5	885.0	18.0	901.0	57,800
Hog	1969 - 70	0.33	1,520.0	1,520.0	1,535.0	32.0	1,547.0	42,500
Hook East	1968 - 69	0.18	1,197.5	1,198.0	1,210.9	37.0	1,215.0	22,300
Hook West	1970 - 71	0.17	1,144.8	1,145.0	1,158.9	40.0	1,167.0	21,600
Inverness	1982 - 83	0.03	1,253.0	1,252.9	1,256.7	20.0	1,261.0	3,300
Irving Drive	1974 - 75	0.03	905.8	905.0	915.3	12.0	920.0	1,200
Kinneloa	1964 - 65	0.20	1,370.0 (15)	1,370.0 (15)	1,403.4 (15)	76.0 (15)	1,407.9 (15)	35,800 (15)
Kinneloa - West	1966 - 67	0.19	1,385.0	1,385.0	1,412.7	22.0	1,421.0	35,000
Lannan	1954 - 55	0.25	1,016.0	1,015.0	1,035.8	14.0	1,043.0	41,400
La Tuna	1955 - 56	5.34	1,109.0	1,110.0	1,140.0	75.0	1,157.0	495,300
Las Flores	1935 - 36	0.45	1,685.1	(9)	1,715.6	50.0	1,726.4	55,600
Las Lomas	1983 - 84	0.07	887.0	887.0	906.0	77.0	908.5	17,900 (15)
Limekiln	1963 - 64	3.72	992.0	992.0	1,003.0	77.0	1,019.0	171,600
Lincoln	1935 - 36	0.50	1,275.8	1,276.0	1,304.0	56.0	1,322.5	38,400
Linda Vista	1970 - 71	0.37	979.5	979.5	989.8	40.0	995.7	3,200
Little Dalton	1959 - 60	3.31	1,140.0	1,139.5	1,186.0	84.0	1,200.2	660,500
Maddock	1954 - 55	0.26	888.6	891.8	901.0	36.0	904.0	45,000
Marston/Paragon	1988 - 89	0.20	1,455.6	1,455.6	1,460.0	20.0	1,466.0	6,100
May No. 1	1953 - 54	0.70	1,666.0	1,666.0	1,684.0	60.0	1,692.5	64,000
May No. 2	1953 - 54	0.09	1,663.4	1,663.5 (2)	1,669.5	20.0	1,674.0	13,400
Monument	1981 - 82	0.11	943.8	942.3	950.0	12.0	954.0	6,800
Morgan	1964 - 65	0.60	1,136.3	1,135.0	1,162.8	45.0	1,171.5	78,500
Mountbatten	1983 - 84	0.01	1,136.2	1,135.5	1,140.9	20.0	1,141.0	1,400
Mull	1973 - 74	0.15	1,146.9	1,147.0	1,154.0	20.0	1,165.0	12,500
Mullally (11)	1974 - 75	0.34	2,420.0	2,420.0	2,435.4	42.0	2,439.6	9,400
Nichols	1937 - 38	0.94	480.5	481.0	485.1	50.0	495.0	14,100
Oak	1975 - 76	0.05	2,145.4	2,145.7	2,151.8	50.0	2,156.2	12,000 (15)
Oakglade	1974 - 75	0.06	1,274.6	1,280.0	1,290.0	20.0	1,296.0	7,250
Oakmont View Drive	1984 - 85	0.02	1,315.5	1,315.5	1,327.5	20.0	1,328.5	3,400
Oliver	1989 - 90	0.18	1,258.0	1,258.0	1,278.3	41.0	1,283.3	32,100

# LOS ANGELES COUNTY DEPARTMENT OF PUBLIC WORKS

## DEBRIS BASIN - DESIGN DATA

Including 1995-1996 Storm Season

DATA SHEET A

Compiled by: Hydraulic and Water Conservation Division  
Sedimentation Mana

Date: October 15, 1996

FILE: DSA96.XLS

DEBRIS BASIN	FIRST DEBRIS SEASON	UNCONTROLLED DRAINAGE AREA ABOVE BASIN (SQ. MI.)	BOTTOM ELEV. AT MAX CAP. (FT.)	ELEVATION PORT INVERT (FT.)	ELEVATION SPILLWAY CREST (FT.)	ELEVATION WIDTH SPILLWAY (FT.)	ELEVATION CREST OF DAM (FT.)	MAXIMUM DEBRIS CAPACITY (CU. YDS.)
Pickens	1935 - 36	1.50	1,563.6	1,564.0	1,600.0	123.0	1,613.0	125,100
Pinelawn	1973 - 74	0.02	2,431.0	2,430.5	2,443.0	(7)	2,448.5	3,200
Rowley	1953 - 54	0.21	1,703.6	1,703.5	1,714.0	60.0	1,722.0	43,100
Rowley (Upper)	1976 - 77	0.31	1,926.0	1,926.0	1,946.0	42.0	1,951.3	28,800
Rubio	1943 - 44	1.26	1,582.1	1,582.1	1,608.3	59.0	1,625.5	127,200 (17)
Ruby (Lower)	1955 - 56	0.28	810.8	809.6	828.0	45.0	833.0	28,600
Rye	1981 - 82	1.11	1,073.9	1,073.8	1,077.7	58.2	1,081.5	19,100
Saddleback	1988 - 89	0.04	1,781.1	1,779.3	1,790.9	23.5	1,796.8	15,000
Santa Anita	1959 - 60	1.70	748.5	748.5 (3)	774.7	160.0	796.0	394,600
Sawpit	1954 - 55	2.82	930.3	930.3	982.0	110.0	1,000.0	635,700
Scholl	1945 - 46	0.16	950.0	950.0 (2)	956.0	76.0	966.0	9,300
Schoolhouse	1962 - 63	0.28	1,459.6	1,460.0	1,478.5	20.0	1,491.0	67,700
Schwartz	1976 - 77	0.25	1,294.7	1,294.7	1,313.2	35.0	1,319.0	45,400
Shields	1937 - 38	0.06	2,050.0	2,050.0	2,058.1	30.0	2,070.2	34,800
Sierra Madre Dam (12)	1927 - 28	2.39	1,119.6	1,119.5	1,172.5	62.5	1,175.0	136,400
Sierra Madre Villa	1957 - 58	1.46	1,069.2	1,069.2	1,088.9	48.0	1,102.5	402,300
Snover	1936 - 37	0.21	1,862.8	1,862.7	1,879.0	40.0	1,893.7	24,800
Sombrero	1969 - 70	1.06	1,539.6	1,540.0	1,564.8	45.0	1,580.0	87,900
Spinks	1958 - 59	0.44	750.0	750.0	761.5	40.0	765.9	56,000
Starfall	1973 - 74	0.13	2,428.0	2,428.0	2,441.5	30.0	2,446.5	14,900
Stetson	1969 - 70	0.29	1,556.0	1,555.0	1,570.0	32.0	1,579.0	41,300
Stough	1940 - 41	1.65	1,006.0	1,005.8	1,031.5 (4)	100.0	1,043.5	180,600
Sturtevant	1967 - 68	0.03	975.0	971.0	983.6	8.0	990.0	1,400
Sullivan	1970 - 71	2.38	570.0	570.0	587.0	50.0	599.3	51,000
Sunnyside	1970 - 71	0.02	1,290.0	1,290.0	1,299.5	15.0	1,303.8	3,400
Sunset Canyon-Deer	1982 - 83	0.21	1,382.4	1,380.5	1,401.8	24.0	1,409.1	5,000
Sunset (Lower)	1963 - 64	0.45	1,003.8	994.5	1,040.0	40.0	1,056.0	158,900
Sunset (Upper)	1928 - 29	0.44	1,574.2	1,574.0	1,603.7	75.0	1,610.1	15,900
Turnbull	1952 - 53	0.99	476.1	475.6	492.0	40.0	503.0	21,600
Upper Shields	1976 - 77	0.21	2,498.0	2,498.0	2,529.9	33.0	2,537.2	40,200 (18)
Verdugo	1935 - 36	9.40	1,109.5	1,110.0	1,119.7	145.0	1,131.0	131,000
Ward	1956 - 57	0.12	2,021.8	2,022.0	2,043.0	58.0	2,035.3	26,400
West Ravine	1935 - 36	0.25	1,468.8	1,469.6 (1)	1,501.9	20.0	1,505.5	44,900
Westridge	1974 - 75	0.02	894.0	894.0	901.0	10.7	906.0	1,400 (14)
Wildwood	1967 - 68	0.65	1,342.9	1,342.9	1,354.0	50.0	1,360.0	20,700
William S. Hart Park	1983 - 84	0.09	1,282.5	1,280.0	1,290.0	19.0	1,293.0	2,400
Wilson	1962 - 63	2.58	1,493.0	1,493.0	1,526.0	60.0	1,543.0	313,100
Winery	1968 - 69	0.18	1,920.0	1,920.0	1,935.0	20.0	1,945.0	29,200



**LOS ANGELES COUNTY DEPARTMENT OF PUBLIC WORKS**

**DEBRIS BASIN - DESIGN DATA**

Including 1995-1996 Storm Season

DATA SHEET A

Compiled by: Hydraulic and Water Conservation Division  
Sedimentation Mana

Date: October 15, 1996

FILE: DSA96.XLS

DEBRIS BASIN	FIRST DEBRIS SEASON	UNCONTROLLED DRAINAGE AREA ABOVE BASIN (SQ. MI.)	BOTTOM ELEV. AT MAX CAP. (FT.)	ELEVATION PORT INVERT (FT.)	ELEVATION SPILLWAY CREST (FT.)	WIDTH SPILLWAY (FT.)	ELEVATION CREST OF DAM (FT.)	MAXIMUM DEBRIS CAPACITY (CU. YDS.)
Zachau	1956 - 57	0.35	1,803.4	1,803.1	1,820.5	44.0	1,823.0	47,900
<b>115 DEBRIS BASINS</b>		<b>62.07</b>						<b>7,754,350</b>

# LOS ANGELES COUNTY DEPARTMENT OF PUBLIC WORKS

## DEBRIS BASIN-DESIGN DATA

Including 1995-96 Storm Season

### DATA SHEET A

Compiled by: Hydraulic and Water Conservation Division  
Sedimentation Management Unit

Date: October 15, 1996

File: DSAR96.WPD

### FOOTNOTES

- (1) Lowest clear water outlet, not spillway.
- (2) Elevation of spillway notch.
- (3) Flow line of sluiceway.
- (4) Elevation of spillway into outlet channel. Elevation of overflow spillway 1,036.9 feet.
- (5) One 30-inch reinforced concrete pipe.
- (6) Four 36-inch corrugated metal pipes.
- (7) One 36-inch reinforced concrete pipe. (Elevated inlet)
- (8) Debris capacity available within right of way limits.
- (9) Pit-type basin.
- (10) Information unavailable.
- (11) Special cleanout required due to limited storage.
- (12) Cleanout required when debris reaches or exceeds elevation 1128.9 feet against face of dam.
- (13) Values are combined with Cooks debris basin.
- (14) Spillway level storage capacity.
- (15) Data taken from design drawings.
- (16) 7 feet in diameter circular outlet type.
- (17) The facility is currently under construction. The basin's maximum capacity will be updated after the enlargement is completed.
- (18) New maximum capacity based on "As-Built" topographic map number 78B-T56.

**LOS ANGELES COUNTY DEPARTMENT OF PUBLIC WORKS**  
**DEBRIS BASIN-DEBRIS PRODUCTION HISTORY**  
 Including 1995 -1996 Storm Season

DATA SHEET B

Compiled by: Hydraulic and Water Conservation Division  
 Sedimentation Management Unit

Date: October 15, 1996

File: DSB96.XLW

DEBRIS BASIN	DPA ZONE	NUMBER OF SEASONS	TOTAL DEBRIS DEPOSITED (CU. YDS.) (1)	AVERAGE ANNUAL DEBRIS PRODUCTION (CU.YDS./YR)	MAXIMUM SEASONAL DEBRIS PRODUCTION		ESTIMATED CONDITIONS		
							DEBRIS STORED CU. YDS.	CAPACITY AVAILABLE	
								CU. YDS.	PERCENT
Aliso	4	26	243,717	9,374	52,206	1994-95	0	41,700	100 (5)
Arbor Dell	2	25	1,481	59	800	1979-80	500	11,900	96
Auburn (9)	1	42	104,616 (13)	2,491	20,100	1961-62	500	37,200	99
Bailey (9)	1	51	295,051	5,785	91,000	1979-80	3,240	125,560	97
Beatty	1	26	14,111	543	7,600	1979-80	4,050	38,950	91
Bigbriar	1	25	4,140	166	866	1992-93	0	2,600	100
Big Dalton	1	37	859,003	23,216	296,700	1968-69	31,200	486,600	94
Blanchard	1	28	78,371	2,799	36,600	1977-78	1,560	72,940	98
Blue Gum	1	28	41,619	1,486	19,100	1977-78	360	39,240	99
Brace	2	25	41,805	1,672	12,000	1977-78	2,250	28,050 (11)	93 (11)
Bracemar	2	25	671	27	283	1980-81	135	565 (15)	81 (15)
Bradbury	1	42	274,161	6,528	70,200	1968-69	8,000	81,800	91
Brand	1	61	276,813 (13)	4,538	53,100	1977-78	6,100	159,900	96
Buena Vista	1	11	440	40	400	1992-93	0	21,800	100
Carriage House (9)	1	26	7,946	306	3,400	1979-80	100	6,000	98
Carter (9)	1	42	42,966	1,023	12,600	1979-80	135	14,365	99
Cassara	1	20	29,687	1,484	16,800	1977-78	2,500	34,200	93
Chamberlain	2	22	1,147	52	300	1974-75	-135	4,835	103
Chandler	2	(11)	(11)	(11)	(11)	(11)	0	20,300 (11)	100 (11)
Childs	1	33	46,518	1,410	10,700	1980-81	1,500	48,900	97
Cloud Creek	1	24	4,232	176	1,800	1977-78	300	4,800	94
Cloudcroft	4	23	13,992	608	6,100	1973-74	3,070	31,630	91
Cooks	1	45	174,821 (3)	3,885 (3)	61,200 (3)	1977-78	1,800 (3)	83,800 (3)	98 (3)
Cooks M-1A	1	21	(8)	(8)	(8)	(8)	(8)	(8)	(8)
Crestview	1	13	(6)	(6)	(6)	(6)	0	5,900 (15)	100 (15)
Crocker	8	13	11,271 (13)	867	5,745	1991-92	0 (14)	19,300 (15)	100 (14,15)
Deer	1	42	171,511	4,084	44,200	1968-69	4,200	52,400	93
Denivelle	2	20	9,837	492	5,500	1977-78	560	7,340	93
Devonwood (9)	1	15	10,215	681	5,800	1993-94	0	10,800 (11)	100 (11)
Dry Canyon-South Fork	4	18	8,968	498	5,300	1979-80	480	7,420	94
Dunsmuir	1	61	380,728	6,241	86,200	1977-78	4,800	97,900	95
Eagle	1	60	200,081 (13)	3,335	41,700	1937-38	6,150	56,950	90
Elmwood	1	32	56,061	1,752	16,100	1980-81	2,650	58,450	96
Emerald-East	2	32	13,966	436	1,800	1985-86	3,450	10,150	75 (14)
Englewild	1	35	87,500 (2)	2,500	60,200 (2)	1968-69	2,430	38,170	94
Fair Oaks (9)	1	61	116,240	1,906	15,700	1935-36	0	23,800	100
Fern (9)	1	61	188,352	3,088	23,900	1968-69	20	43,180 (11)	100 (11)
Fieldbrook	6	22	2,354	107	500	1991-92	100	2,700	96
Golf Club Drive	2	26	34,893	1,342	11,600	1979-80	0	14,700	100
Gordon	1	23	5,804	252	3,800	1977-78	200	32,400	99
Gould	1	49	122,274	2,495	18,000	1965-66	1,390	51,410	97
Gould (Upper)	1	20	39,178	1,959	11,177	1991-92	3,665	48,635	93
Halls	1	61	612,877	10,047	102,100	1937-38	6,700	82,700	93
Harrow	1	38	78,498 (2)	2,066	63,400 (2)	1968-69	-5,360	73,360	108
Haven Way	2	5	(6)	(6)	(6)	(6)	0	38,200	100
Hay	1	60	75,762 (13)	1,263	18,200	1937-38	740	35,960	98
Hillcrest	1	34	52,649	1,549	11,700	1964-65	4,450	53,350	92
Hog	1	27	10,934	405	3,900	1977-78	7,000 (16)	35,500 (16)	84 (16)

**LOS ANGELES COUNTY DEPARTMENT OF PUBLIC WORKS**  
**DEBRIS BASIN-DEBRIS PRODUCTION HISTORY**  
 Including 1995 -1996 Storm Season

**DATA SHEET B**

Compiled by: Hydraulic and Water Conservation Division  
 Sedimentation Management Unit

Date: October 15, 1996

File: DSB96.XLW

DEBRIS BASIN	DPA ZONE	NUMBER OF SEASONS	TOTAL DEBRIS DEPOSITED (CU. YDS.) (1)	AVERAGE ANNUAL DEBRIS PRODUCTION (CU.YDS./YR)	MAXIMUM SEASONAL DEBRIS PRODUCTION		DEBRIS STORED CU. YDS.	ESTIMATED CONDITIONS	
					CU. YDS.	SEASON		CU. YDS.	PERCENT
Hook East	1	28	46,629 (2)	1,665	40,200 (2)	1968-69	20	22,280	100
Hook West	1	26	7,288	280	3,600	1979-80	450	21,150	98
Inverness	2	14	498	36	252	1982-83	700	2,600	79
Irving Drive	2	22	1,756	80	600	1980-81	10	1,190	99
Kinneloa (9)	1	32	108,452 (2)	3,389	36,366	1993-94	350	35,450 (11)	99 (11)
Kinneloa West (9)	1	30	143,607 (2)	4,787	34,754	1993-94	1,985	33,015	94
Lannan	1	42	84,767	2,018	18,200	1969-70	700	40,700	98
La Tuna	2	41	652,524	15,915	172,100	1977-78	45,165	450,135	91
Las Flores (9)	1	61	239,060	3,919	36,000	1937-38	0	55,600	100
Las Lomas	1	13	615	47	(6)	(6)	10	17,890 (11)	100 (11)
Limekiln	4	33	348,858	10,571	43,610	1994-95	0	171,600	100
Lincoln (9)	1	61	139,793	2,292	28,400	1968-69	0	38,400	100
Linda Vista	2	26	14,389	553	3,400	1977-78	0	3,200	100
Little Dalton	1	37	928,373	25,091	337,800	1968-69	39,240	621,260	94
Maddock	1	42	57,134	1,360	16,200	1980-81	2,200	42,800	95
Marston/Paragon	5	8	130	16	(6)	(6)	270	5,830	96
May No. 1 (9)	2	43	233,384	5,428	45,800	1968-69	0	64,000	100
May No. 2	2	43	28,016	652	6,200	1966-67	0	13,400	100
Monument	6	15	2,787	186	2,600	1981-82	20	6,780	100
Morgan	1	32	30,841	964	12,900	1968-69	0	78,500	100
Mountbatten	1	13	110	8	(6)	(6)	40	1,360	97
Mull	1	23	2,444	106	1,100	1979-80	550	11,950	96
Mullally (9)	1	22	65,706 (4)	2,987	24,400 (4)	1977-78	0	9,400	100
Nichols	4	59	131,334	2,226	21,800	1951-52	30	14,070	100
Oak	1	21	13,267	632	6,900	1977-78	0	12,000 (11)	100 (11)
Oakglade	1	22	1,657	75	1,200	1977-78	740	6,510	90
Oakmont View Drive	1	12	621	52	221	1991-92	55	3,345	98
Oliver	1	7	31,980 (7)	4,569	16,255 (7)	1977-78	1,600	30,500	95
Pickens	1	61	731,007	11,984	140,600	1977-78	1,900	123,200	98
Pinelawn	1	23	5,509	240	1,200	1976-77	330	2,870	90
Rowley	1&7	43	79,235 (4)	1,843	13,000 (4)	1977-78	3,000	40,100	93
Rowley (Upper)	1	20	51,805 (4)	2,590	31,900 (4)	1977-78	-575	29,375	102
Rubio (9)	1	53	345,798	6,524	133,000	1979-80	0	127,200	100 (12)
Ruby (Lower)	1	41	21,032	513	8,300	1968-69	1,600	27,000	94
Rye	5	15	17,704	1,180	10,000	1981-82	1,200	17,900	94
Saddleback	1	8	4,020	503	1,060	1995-96	1,060	13,940	93
Santa Anita	1	37	755,383 (2,3)	20,416	132,000 (2,3)	1961-62	-3,330	397,930	101
Sawpit	1	42	700,497 (2,3)	16,679	232,200 (2,3)	1968-69	13,500	622,200	98
Scholl	2	51	20,072	394	1,780	1994-95	50	9,250	99
Schoolhouse	1	34	34,490	1,014	21,600	1962-63	5,225	62,475	92
Schwartz	1	20	49,859	2,493	21,600	1977-78	4,800	40,600	89
Shields	1	59	133,930 (3)	2,270	7,800	1937-38	1,810	32,990	95
Sierra Madre Dam(9&10)	1	69	374,822 (2)	5,432	95,200 (2)	1968-69	0	136,400	100
Sierra Madre Villa (9)	1	39	783,502	20,090	171,775	1993-94	9,080	393,220	98
Snover	1	60	109,960	1,833	19,300	1938-39	480	24,320	98
Sombrero	1	27	14,355	532	3,300	1977-78	8,500	79,400	90
Spinks	1	38	68,372	1,799	15,600	1968-69	1,990	54,010	96
Starfall	1	23	29,123	1,266	14,200	1977-78	1,950	12,950	87

**LOS ANGELES COUNTY DEPARTMENT OF PUBLIC WORKS**  
**DEBRIS BASIN-DEBRIS PRODUCTION HISTORY**  
 Including 1995 -1996 Storm Season

DATA SHEET B

Compiled by: Hydraulic and Water Conservation Division  
 Sedimentation Management Unit

Date: October 15, 1996

File: DSB96.XLW

DEBRIS BASIN	DPA ZONE	NUMBER OF SEASONS	TOTAL DEBRIS DEPOSITED (CU. YDS.) (1)	AVERAGE ANNUAL DEBRIS PRODUCTION (CU. YDS./YR)	MAXIMUM SEASONAL DEBRIS PRODUCTION		DEBRIS STORED CU. YDS.	ESTIMATED CONDITIONS	
					CU. YDS.	SEASON		CAPACITY AVAILABLE	
								CU. YDS.	PERCENT
Stetson (9)	1	27	22,052	817	1,500	1977-78	700	40,600	98
Stough	2	56	162,119	2,895	44,100	1964-65	2,800	177,800	98
Sturtevant	1	29	1,376	47	500	1977-78	175	1,225	88
Sullivan	4	26	116,492 (13)	4,480	35,300	1979-80	1,500	49,500	97
Sunnyside (9)	1	26	4,289	165	1,621	1993-94	125	3,275	96
Sunset Canyon-Deer	1	14	4,192	299	3,400	1982-83	215	4,785	96
Sunset (Lower)	1	33	143,580	4,351	20,200	1980-81	3,700	155,200	98
Sunset (Upper)	1	68	149,680	2,201	27,000	1964-65	-1,470	17,370	109
Turnbull	6	44	72,692 (2)	1,652	15,900 (2)	1968-69	200	21,400	99
Upper Shields	1	20	43,247 (4,7)	2,162	16,900 (4,7)	1977-78	15	4,185	100
Verdugo	1	61	827,992	13,574	105,400	1937-38	13,335	117,665	90
Ward	1	40	52,671	1,317	17,800	1977-78	1,230	25,170	95
West Ravine (9)	1	61	172,514 (13)	2,828	29,900	1937-38	70	44,830	100
Westridge	1&7	22	293	13	(6)	(6)	280	1,120 (15)	80 (15)
Wildwood	3&5	29	91,812	3,166	16,700	1977-78	0	20,700	100
William S. Hart Park	5	13	755	58	600	1983-84	0	2,400	100
Wilson	2	34	216,133	6,357	55,500	1968-69	15,170	297,930	95
Winery	1	28	27,215	972	9,400	1968-69	0	29,200	100
Zachau	1	40	111,181 (4)	2,780	48,100 (4)	1977-78	2,950	44,950	94
<b>115 DEBRIS BASINS</b>			<b>14,714,016</b>	<b>354,634</b>			<b>298,482</b>	<b>7,419,852</b>	

# LOS ANGELES COUNTY DEPARTMENT OF PUBLIC WORKS

## DEBRIS BASIN-DEBRIS PRODUCTION HISTORY

Including 1995-96 Storm Season

### DATA SHEET B

Compiled by: Hydraulic and Water Conservation Division  
Sedimentation Management Unit

Date: October 15, 1996

File: DSB96.WPD

### FOOTNOTES

- (1) Volume of debris deposited in basins does not include debris sluiced through open ports or notch.
- (2) Volume of debris deposited in basins does not include debris which passed over spillway during the storms in 1968-69 season.
- (3) Including debris from upstream basin or dam.
- (4) Volume of debris deposited in basins does not include debris which passed over spillway during the storms in 1977-78 season.
- (5) Debris capacity available within right of way limits.
- (6) No significant debris inflows recorded.
- (7) Including debris data from previous basin.
- (8) Values are combined with Cooks debris basin.
- (9) Special clean out required due to burned watershed. For Mullally debris basin it is due to limited storage.
- (10) Clean out required when debris reaches or exceeds elevation 1128.9 feet against face of dam.
- (11) Based on design drawings used for enlarging the basin capacity. The data will be revised based on updated topographic map.
- (12) The debris basin is currently under construction. The estimated conditions will be updated after enlargement is completed.
- (13) The total debris deposited or the amount stored of the previous storm-season year was adjusted based on revised/new data.
- (14) Facility scheduled for cleaning.
- (15) Based on maximum capacity at spillway level storage capacity.
- (16) Data based on new approved cut plan. The estimated debris stored includes 2,500 c.y. of native material to be excavated to achieve the new maximum capacity.





PEACE FIRE  
518 ACRES, 7/28/95  
TG PAGE X (1995 EDITION)  
KERN

110TH STREET FIRES  
550 ACRES, 9/23/95  
TG PAGES 3923, 4013, AND 4103 (1995 EDITION)

AGUA DULCE FIRE  
1,114 ACRES, 10/8/94 - 10/9/94  
TG PAGE 4463/A6-7, B5-7, C4-7, D4-6

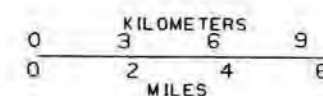
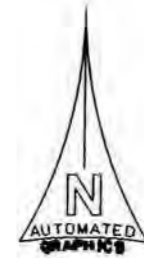

MAP OF

# COUNTY OF LOS ANGELES

DEPARTMENT OF PUBLIC WORKS

OCT. 1, 1994 THRU  
SEPT. 30, 1995 FIRES

OVER 500 ACRES IN AREA

BURNED AREA LOCATIONS



ELIZABETH LAKE FIRE  
 600 ACRES. 6/19/96  
 TG PAGE 4102/J2-3, 4103/A2-4, B3-4, C3-4 (1993 EDITION)  
 SOME HOMES MAY BE IMPACTED.

CASTAIC FIRE  
 21,500 ACRES. 8/26/96 TO 9/3/96  
 TG PAGE VIII. 1995 EDITION  
 MOST DEBRIS WILL FLOW INTO CASTAIC LAKE, AND REMOTE CANYONS.  
 MINOR DEBRIS FLOW ALONG NORTH BOUND LANE OF FRWY 5  
 NEAR CASTAIC LAKE CAN BE EXPECTED.  
 NO HOUSES WILL EXPERIENCE DEBRIS FLOW.

CAMP FIRE  
 900 ACRES. 9/7/96 TO 9/9/96  
 TG PAGE VIII. 1995 EDITION  
 SOME DEBRIS MAY FLOW INTO STEAM AND MAY PLUG INLET.  
 MINOR DEBRIS FLOW ALONG SOUTH BOUND GUTTER OF SFC ROAD  
 NEAR STATE PRISON CAMP CAN BE EXPECTED.  
 NO HOUSES WILL EXPERIENCE DEBRIS FLOW.

TOWSLEY FIRE  
 812 ACRES. 12/4-5/95  
 TG PAGE 4550 E5, F5 (1995-EDITION)

FREEWAY 14 FIRE  
 1,370 ACRES. 10/5/95  
 TG PAGE 4462 AND 4463 (1995-EDITION)  
 SOME HOMES AND DEPARTMENT FACILITIES MAY BE AFFECTED.

RESERVOIR FIRE  
 1,428 ACRES. 8/25-28/96  
 TG PAGE 509/D5 (1995 EDITION)  
 POSSIBLE DEBRIS FLOW ON S.G.C. ROAD

BICHOTA COMPLEX FIRE  
 1,115 ACRES. 7/4-5/96  
 TG PAGE 4729/G7 H7 (1992 EDITION)  
 SOME HOMES MAY BE AFFECTED.

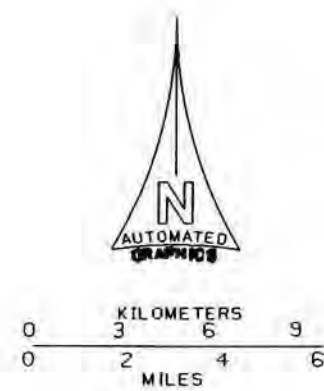

MAP OF  
**COUNTY OF LOS ANGELES**  
 DEPARTMENT OF PUBLIC WORKS  
 OCT. 1, 1995 THRU  
 SEPT. 30, 1996 FIRES  
 OVER 500 ACRES IN AREA  
 BURNED AREA LOCATIONS



# **WATER QUALITY**

## **WATER QUALITY**

Since its inception, the Flood Control District (now Department of Public Works) has actively engaged in operations that have proven indispensable in preserving the integrity of our water resources in both quantity and quality.

Prior to March 1986, water quality monitoring was conducted by the Water Quality Section of Hydraulic/Water Conservation Division. In March 1986, the program was transferred to Waste Management Division, now known as Environmental Programs Division (EPD). The program includes the collection and analysis of surface water samples and the interpretation and reporting of the results.

Areas of involvement included the monitoring of storms and low flows at various strategic locations on the County's major streams and channels. In 1995, the Department of Public Works began its first season of stormwater runoff monitoring required by the National Pollutant Discharge Elimination System (NPDES) municipal stormwater permit. The permit, administered by the Department on behalf of the County, is issued by the Los Angeles Regional Water Quality Control Board. During the 1994-95 and 1995-96 storm seasons, both manual grab sampling and automated flow-composite sampling were performed in various storm drains and channels.

The Water Quality Section and the Industrial Waste Section of Environmental Programs Division, together with personnel from other Departmental divisions, also conduct investigations into pollution problems relative to our facilities, particularly those from industrial discharges, vehicle accidents, ruptured pipelines or other indiscriminate dumping of various waste products. The principal objectives of these investigations are to determine the degree and apparent source of pollution and to take the necessary action that will immediately abate existing problems and possibly provide a means to prevent or limit recurrence.

Since 1986, the Water Quality Section also has been conducting the screening of proposed connections to County storm drains and developments over County rights-of-way for the purpose of minimizing or eliminating potential pollutants entering the storm drain and thereby the environment.

The NPDES Municipal Stormwater Permit (CA0061654) issued in 1990 required the County to develop and implement a stormwater/urban runoff monitoring program to gather data on the type of pollutants within the drainage basins. The permit also required the development and implementation of Best Management Practices (BMPs) to reduce the amount of pollutants that find their way into the storm drain system and to implement procedures to detect and eliminate illegal discharges.

## **SURFACE WATER SAMPLING**

Prior to 1984, dry weather samples were collected from 30 sampling stations on a monthly basis for analyses such as general minerals, bacteria, pesticides, and heavy metals. In addition, storm samples were collected and analyzed at least three times annually from the same 30 stations during storm season.

From 1984 to 1987, as a result of reorganization, the number of surface water monitoring stations

was reduced to 21, while the parameters analyzed were reduced to include only total dissolved solids, pH, and dissolved oxygen. Storm sampling activities were also significantly curtailed.

In 1988, recognizing the inadequacy of the then-existing monitoring program to meet the Department's need in dealing with important issues in the areas of water quality, the Department Administration approved and implemented an expanded monitoring program effective May 1, 1988.

Starting in January 1995, in compliance with Phase I requirements of the NPDES permit, nine (9) automated sampling stations began sampling runoff from combinations of mass emissions and land use specific watersheds within the Santa Monica Bay drainage area. In October 1995, the Department implemented Phases II and III of the permit with the installation of eight (8) automated sampling stations in the Los Angeles River watershed, four (4) stations in the San Gabriel River watershed, one (1) station in the Santa Clara River watershed, and two (2) stations in the Dominguez Channel watershed.

These automated stations incorporate flow measuring instrumentation that collect and store streamflow data and activate water sampling equipment. The equipment automatically collects flow-weighted composite samples. In addition, grab samples for those constituents not able to be collected by automated sampling equipment due to sample preservation needs or short holding times-- VOC's, bacteria, oil and grease, total phenols, and cyanide--were also collected. The water sampling equipment pumps stormwater from within the drain into refrigerated storage bottles that are later retrieved and taken to the laboratory for analysis. Although grab samples only characterize water quality at the exact time of collection, they provide a "snapshot" characterization of the existing water quality.

The detected levels of constituents tested from both the grab and composite samples obtained from the automated stations are presented in a report titled "Report of Stormwater Monitoring, Winter of 1994-95". This report can be obtained by contacting our Environmental Programs Division at (818) 458-6972.

The Department's historic grab sampling program continued Countywide throughout the entire 1994-95 season, monitoring six storms at 21 of the 28 open channel sites also monitored monthly for dry weather flows. Collection of samples at the historic sites were performed manually, and only one grab sample per storm sampling event, and for dry flow sampling event was collected per station. The detected levels of the tested constituents are likewise included in the Report of Stormwater Monitoring organized by watershed. Starting in the 1995-96 storm season, the Department discontinued its historic grab sampling efforts in favor of the sampling program it initiated under the NPDES Municipal Stormwater Permit.

## **GROUNDWATER QUALITY**

The Department's Groundwater Monitoring Program, which was initiated in the 1970's, underwent evaluations in September, 1993 and January, 1994 to eliminate duplication of analyses among participating agencies. It was determined that the majority of the 314 wells in the program were already being sampled by the various Watermasters within the County. The Department has discontinued its annual sampling activities for the program. However, Environmental Programs Division maintains the Department's existing historical groundwater quality records and, upon request, can provide data to the public.



## 1994-1995 Surface Monitoring Stations

Los Angeles County Department of Public Works  
Environmental Programs Division Water Quality Section

### ◆ NPDES Automated Sampling Sites:

- S01** Ballona Creek @ Sawtelle Blvd.
- S02** Malibu Creek South of Puma Rd.
- S03** Trancas Canyon @ end of Paso Canyon Dr.
- S04** Kenter Canyon @ Main St.
- S05** Project 1105 @ Valley Dr.
- S06** Project 558 @ Paseo Lunado and Via Anacapa
- S07** Project 5401 @ Redondo Ave. and 11th St.
- S08** Santa Monica Pier Storm Drain @ Appian Way
- S09** L. A. City Drain 2361 @ 21 St. and Grand Ave.

### ● Historic Sampling Sites:

- |  |  |
|--|--|
| 1 Ballona Creek @ Fairfax Ave.               | 21 Los Cerritos Channel @ Stearns                    |
| 2 Ballona Creek @ Sawtelle Blvd.             | 22 Rio Hondo Channel @ Rio Hondo Spreading Grounds   |
| 3 Centinela Creek @ Centinel Blvd.           | 23 Rio Hondo Channel @ San Gabriel Blvd.             |
| 4 Dominguez Channel Upstream of Vermont Ave. | 24 Rio Hondo Channel @ Stewart & Gray                |
| 5 Kenter Drain @ Pico Blvd.                  | 25 San Gabriel River @ San Gabriel Spreading Grounds |
| 6 Malibu Creek @ Cross Creek Rd.             | 26 San Gabriel River @ Willow St.                    |
| 7 Santa Clara River @ The Old Road           | 27 San Jose Creek @ Workman Mill Rd.                 |
| 8 Santa Monica Cyn. Channel @ Short St.      | 28 Monrovia Creek Above Sawpit Creek                 |
| 9 Sepulveda Channel @ Culver Blvd.           |  |
| 10 Topanga Canyon @ Pacific Coast Hwy.       |  |
| 11 Torrance Lateral @ Main St.               |  |
| 12 Wilmington Drain @ Pacific Coast Hwy.     |  |
| 13 Corral Canyon Creek @ Pacific Coast Hwy.  |  |
| 14 Compton Creek @ Greenleaf Blvd.           |  |
| 15 Coyote Creek @ Orangethorpe Blvd.         |  |
| 16 Coyote Creek @ Willow St.                 |  |
| 17 Los Angeles River @ Arroyo Seco           |  |
| 18 Los Angeles River @ Firestone Blvd.       |  |
| 19 Los Angeles River @ Tujunga Blvd.         |  |
| 20 Los Angeles River @ Wardlow Rd.           |  |

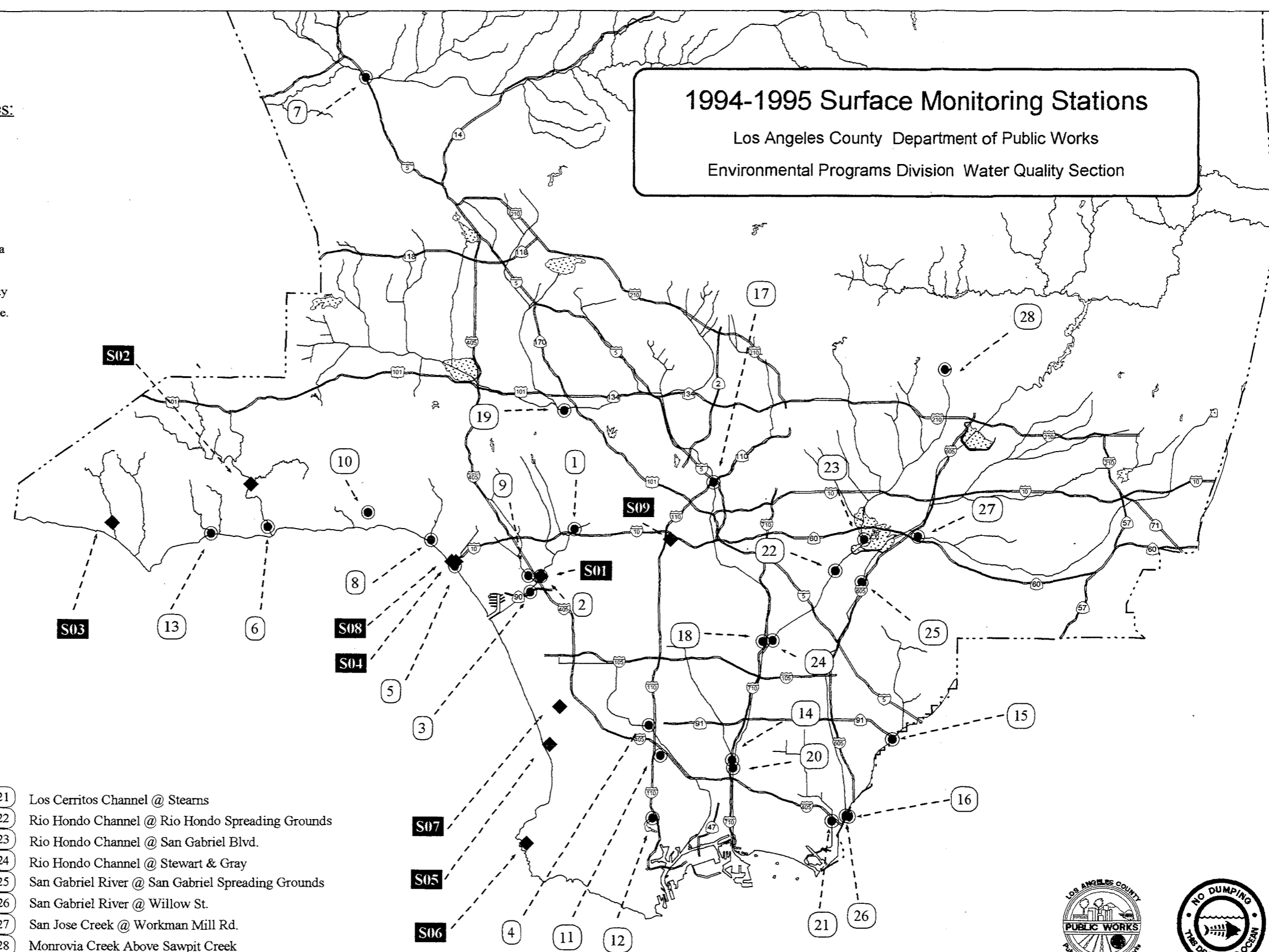

# 1995-1996 Surface Monitoring Stations

Los Angeles County Department of Public Works  
 Environmental Programs Division Water Quality Section

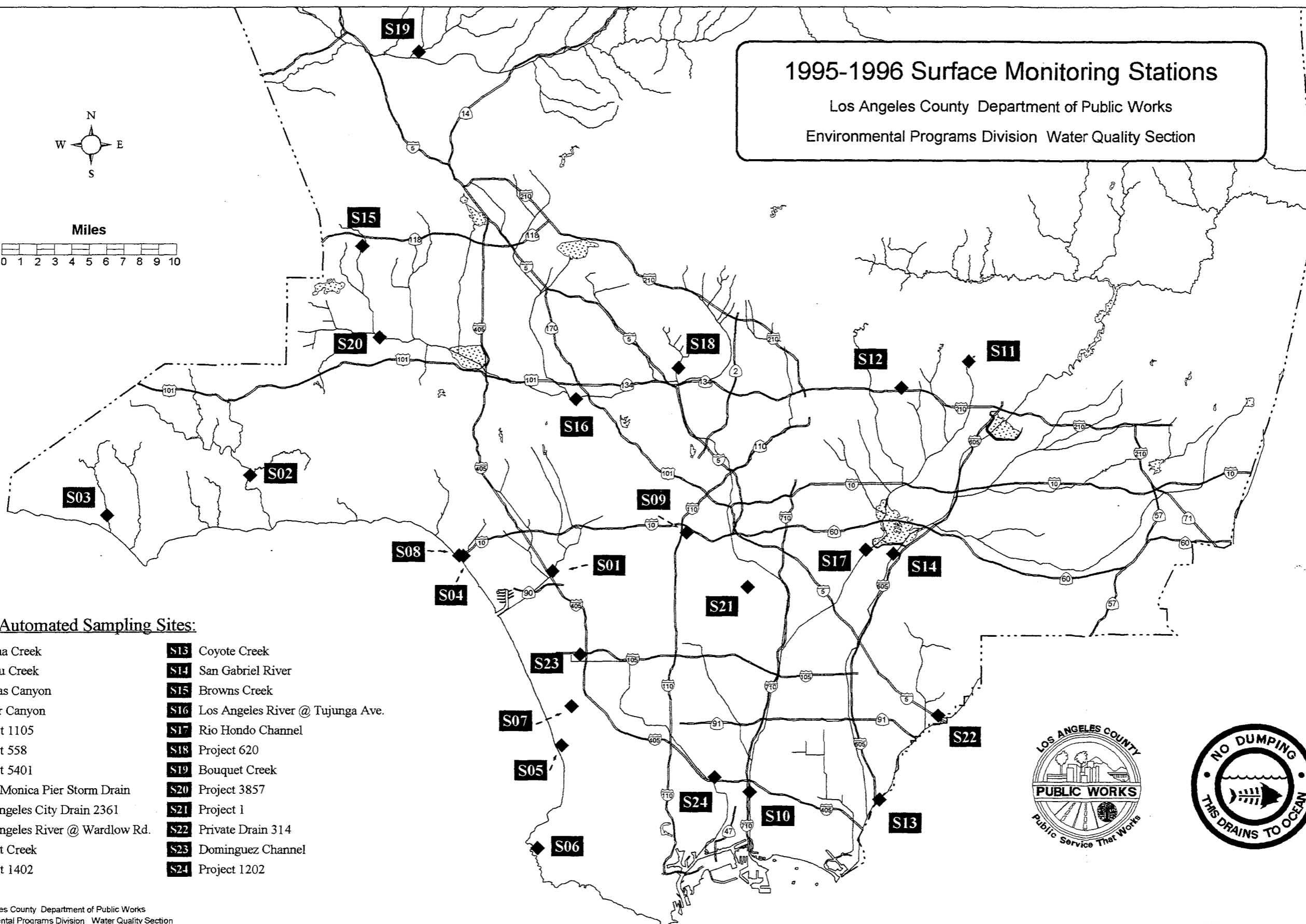
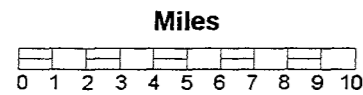
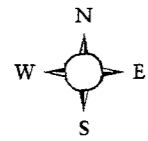

◆ **NPDES Automated Sampling Sites:**

- |                                     |                                      |
|-------------------------------------|--------------------------------------|
| S01 Ballona Creek                   | S13 Coyote Creek                     |
| S02 Malibu Creek                    | S14 San Gabriel River                |
| S03 Trancas Canyon                  | S15 Browns Creek                     |
| S04 Kenter Canyon                   | S16 Los Angeles River @ Tujunga Ave. |
| S05 Project 1105                    | S17 Rio Hondo Channel                |
| S06 Project 558                     | S18 Project 620                      |
| S07 Project 5401                    | S19 Bouquet Creek                    |
| S08 Santa Monica Pier Storm Drain   | S20 Project 3857                     |
| S09 Los Angeles City Drain 2361     | S21 Project 1                        |
| S10 Los Angeles River @ Wardlow Rd. | S22 Private Drain 314                |
| S11 Sawpit Creek                    | S23 Dominguez Channel                |
| S12 Project 1402                    | S24 Project 1202                     |



**WATER  
CONSERVATION**

## **WATER CONSERVATION**

Information presented in this section includes amounts of local, imported, and reclaimed water conserved in spreading areas and information on the seawater barrier projects which prevent salt water intrusion into groundwater zones in the coastal areas. Pertinent data is presented regarding the locations and descriptions of the Department's water conservation facilities, as well as facilities owned by others. Also included are groundwater maps delineating static groundwater elevations recorded during the falls of 1994 and 1995 and the hydrographs of selected key wells.

### **CONSERVING THE WATERS**

In addition to the flood control program, the Department has the equally important mission of conserving as much of the storm and other waters as practicable. The use of water conservation facilities adjacent to river channels, and in soft-bottom channels permits water to percolate into groundwater basins for later pumping. These water spreading facilities are located in areas where the underlying soils are composed of permeable formations and in hydraulic connection with the underlying aquifer.

The various types of water conserved, local, imported, and reclaimed, are construed to have the following meanings in this section: Local water is primarily runoff due to rainfall on the mountain and valley watersheds, dam releases, and rising water within the County. Imported water is water originating outside the County either from Northern California or from the Colorado River. Reclaimed water is the effluent produced by the Whittier Narrows Water Reclamation Plant, the San Jose Creek Water Reclamation Plant, and the Pomona Water Reclamation Plant, all operated by the Los Angeles County Sanitation District.

The importance of this activity is apparent when it is realized that about 30 to 40 percent of the water used in the County is pumped from groundwater supplies. The growth of the County, combined with periodic droughts, has seriously depleted these supplies on numerous occasions.

The Department's policy is to conserve the maximum possible amount of storm water consistent with runoff quantity and quality, capacities of the spreading facilities, and groundwater conditions.

### **IMPORTED WATER**

During the reporting period, the Department received water imported from the Colorado River and the State Water Project by the Metropolitan Water District (MWD), and spread it in the Coastal Plain at the Department's Rio Hondo and San Gabriel Coastal Spreading Grounds on behalf of the Water Replenishment District of Southern California. Imported water in the San Gabriel Valley was spread in Santa Fe Spreading Grounds, in the San Gabriel River, in San Gabriel Canyons, in Little Dalton, in Irwindale Spreading Basin/Manning Pit, and in Forbes Spreading Grounds on behalf of the Upper San Gabriel Valley Municipal Water District, Three Valley Municipal Water District, and the San Gabriel Valley Municipal Water District.

### **RECLAIMED WATER**

The County Sanitation District's Whittier Narrows Water Reclamation Plant effluent, purchased by the Water Replenishment District of Southern California, is transported to the Rio Hondo and San

Gabriel Coastal Basin Spreading Grounds for groundwater replenishment.

The County Sanitation District's San Jose Creek Water Reclamation Plant made its first delivery of effluent in November 1972. The effluent that is spread is purchased by the Water Replenishment District of Southern California.

Water from the Pomona Reclamation Plant is released down the San Jose Creek - San Gabriel River System to the Department's recharge facilities in the San Gabriel Coastal Basin spreading grounds.

The maximum amount of reclaimed water allowed for spreading in the Montebello Forebay, effective July 1991, is 60,000 acre-feet per year, but not to exceed 150,000 acre-feet over a three year period.

#### **SEAWATER BARRIER PROJECTS**

The Department operates three barrier projects to protect the groundwater in the West Coast and Central basins against seawater intrusion by creating freshwater pressure ridges along the coastline. The pressure ridges are created by injecting fresh water through a series of injections wells. During this report period 26,663 acre-feet of imported water and 5,610 acre-feet of reclaimed water was injected at the West Coast Basin Barrier Project. 10,096 acre-feet of imported water was injected at the Dominguez Gap Barrier Project. 6,716 acre-feet of imported water was injected at the Los Angeles part of the Alamitos Barrier Project. On behalf of the Orange County Water district, 2,899 acre-feet of imported water was injected at the Orange County Portion of the Alamitos Barrier project.

Following is a description of the barrier operational optimization changes, facility capital construction improvements, and significant well repair projects implemented at the Department's Seawater Barrier Projects during the 1994-96 water year:

1. Alamitos Barrier Project -

- Engineering and system operational changes were implemented to reduce the historical seasonal water level declines along the barrier alignment associated with inland basin extractions.
- Three injection wells with persistent surface leakage problems were successfully repaired by Department Staff pressure grouting the confining cap with bentonite and cement grouts.

2. Dominguez Gap Barrier Project -

- Engineering and system operational changes were implemented to operate the barrier system at augmented injection rates.
- All the observation wells in the barrier system were retrofitted with smaller, lighter water tight vaults.

3. West Coast Basin Barrier Project -

- Construction was completed on 60 observation wells at 26 sites at a capital cost of 2.6 million dollars. These new wells improve the barrier system groundwater monitoring network, provide new geohydrologic information, and provide better definition of regions where the barrier is effective or in need of improvement.
- Reclaimed water transmission facilities were constructed to enable reclaimed water to be blended with imported water for injection at the barrier project.
- Department forces tested and successfully implemented chemical redevelopment procedures at four barrier project injection wells. Department forces also repaired two damaged injection wells with stainless steel sleeves being bonded to the damaged portion of the casing with high strength epoxy.

#### **SEASONAL DATA AND MAPS**

During this report period, weekly, monthly, and semi-annual measurements of groundwater levels in observation wells located throughout the groundwater basins in Los Angeles County were made and processed.

Static groundwater elevation contour maps for L.A. COUNTY and Hydrographs of selected key wells are included in this report.

#### **GROUNDWATER BASINS AND GROUNDWATER RECHARGE**

Groundwater in Los Angeles County is stored in basins underlying five major geographic areas. These groundwater basins are separated by geologic features which impede groundwater movement or by political boundaries. The following is a background summary of the Department's groundwater recharge activities within each of these areas:

The Department operates 2,436 acres of spreading grounds and soft-bottom channel spreading areas for replenishment of local groundwater supplies. The Department also assisted in the operation and maintenance of 269 acres of spreading grounds owned by others. An additional 656 acres of spreading grounds are controlled, maintained, and operated by other agencies. The total gross acreage of spreading grounds in the County is 3,361 acres. During 1994-95, the County index for rainfall was 174 percent of the normal, the Department conserved 401,220 acre-feet of storm runoff. During 1995-96, the County rainfall index was 85 percent of the normal, the Department conserved approximately 177,000 acre-feet of storm runoff.

The conservation of local runoff is supplemented by spreading imported water and reclaimed water purchased by water agencies. During 1994-95, the Department spread 43,033 acre-feet of imported water and 33,300 acre-feet of reclaimed water. During 1995-96 the Department spread 84,954 acre-feet of imported water and 53,867 acre-feet of reclaimed water.

The Department is continuing its efforts to improve its water spreading facilities in order to maximize the amounts of water conserved and to simplify the spreading operations.



## **SAN GABRIEL VALLEY**

The Department operates 20 spreading facilities in the San Gabriel Valley that receive direct valley runoff and flows from the San Gabriel Mountains. Some of these spreading facilities can also receive imported water. During 1994-95, the Department added approximately 222,665 acre-feet of local water and 21,530 acre-feet of imported water to the groundwater stored in the basins underlying the San Gabriel Valley and diverted 8,272 acre-feet of local water to grounds owned by others. During 1995-96, the Department added approximately 81,020 acre-feet of local and 67,070 acre-feet of imported water to the groundwater stored in the basins underlying the San Gabriel Valley and diverted approximately 9,970 acre-feet of local water to grounds owned by others.

### **Main San Gabriel Basin**

This is the largest basin underlying the San Gabriel Valley with an estimated storage capacity of 9.5 million acre-feet. It reacts quickly to artificial spreading in Santa Fe Reservoir Spreading Grounds and to infiltration in the San Gabriel River downstream of Santa Fe Dam.

The Department replenished the Main San Gabriel Basin with 148,340 acre-feet of local water and 15,370 acre-feet of imported water during 1994-95 and 43,450 acre-feet of local water and 39,550 acre-feet of imported water during 1995-96. Well 3030F in Baldwin Park recorded a high groundwater elevation for the report period of 272.2 ft on June 8, 1995 and reached the 250 feet elevation on April 1, 1996.

The following improvements were constructed by the Department in the Upper San Gabriel Canyon Basin during 1994-96 water year:

1. Constructed a 450-ft long and 10-ft high rubber dam in San Gabriel River at Walnut Creek Inlet. It is currently the largest rubber dam in the world.
2. Constructed a 570-ft long and 6-ft high rubber dam at Santa Fe Spreading Grounds. It is currently the longest rubber dam in the world.
3. Constructed new San Gabriel Valley Municipal Water District connection to San Gabriel Canyon Spreading Grounds Basin and Three Valley Municipal Water District connection to Little Dalton Spreading Grounds.

### **Upper San Gabriel Canyon Basin**

The Department replenished the Upper San Gabriel Canyon Groundwater Basin during 1994-95 by approximately 52,800 acre-feet of local water and 5,260 acre-feet imported water and during 1995-96 by approximately 28,700 acre-feet of local water and 21,250 acre-feet of imported water, through its San Gabriel Canyon Spreading Grounds and percolation in the adjacent San Gabriel River. Also, during 1994-95 approximately 5,810 acre-feet and during 1995-96 approximately 7,830 acre-feet were routed to Fish Canyon Spreading Grounds which is operated by a Committee of Nine.

### **Lower San Gabriel Canyon Basin**

The basin is located south of the Upper San Gabriel Canyon Basin and is separated from it by the underground Lohmon Dike. Groundwater cascades over the Lohmond dike from the Upper San

Gabriel Canyon Basin and recharges the Lower San Gabriel Canyon Basin. The Department spread approximately 2,540 acre-feet of local water during 1994-95 and 800 acre-feet of local water during 1995-96 in Sawpit Spreading Grounds which is within the Lower Canyon Basin.

### **Wayhill Basin**

The Department spread approximately 460 acre-feet of local water and 900 acre-feet of imported water during 1994-95 and 290 acre-feet of local water and 1,000 acre-feet of imported during 1995-96 at Forbes spreading facility in the Wayhill Basin.

### **Foothill Basin**

The Department spread approximately 5,550 acre-feet during 1994-95 and 2,425 acre-feet during 1995-96 of local water at its San Dimas Canyon Spreading Grounds facility in the Foothill Basin.

### **Glendora Basin**

The Department spread 2,440 acre-feet of local water during 1994-95 and 1,150 acre-feet of local water and 5,270 acre-feet of imported water during 1995-96 in its Big and Little Dalton facilities within the Glendora Basin.

### **Claremont Heights Basin**

The Department has no spreading facilities in the Claremont Heights Basin.

### **Live Oak Basin**

The Department has no spreading facilities in the Live Oak Basin.

### **Chino Basin**

The basin is located in the most eastern part of the County. No Department recharge facilities are located within the Chino Basin.

### **San Dimas Basin**

The basin is north of the San Jose Hills, east of the Main Basin, and south of the Wayhill Basin. The Department spread 440 acre-feet during 1994-95 and 265 acre-feet during 1995-96 of local water in its Live Oak Spreading Grounds to recharge the basin.

### **Pomona Basin**

The basin is located south of Claremont, Live Oak, and San Dimas Basins, and north of the Chino Basin and northeast of the San Jose Hills. The Department has no water spreading facilities within this basin.

## **Puente and Spadra Basins**

No spreading occurs in this area.

## **Raymond Basin**

The basin covering approximately 40 square miles is located in the northwest corner of the San Gabriel Valley and is separated from the Main San Gabriel Basin by the Raymond Fault. The Raymond Basin contains the Monk Hill Basin and the Pasadena and Santa Anita Subareas. The Department recharged 10,090 acre-feet during 1994-95 and 3,960 acre-feet during 1995-96 of local water by its spreading facilities in the Raymond Basin and diverted 2,460 acre-feet during 1994-95 and 2,140 acre-feet during 1995-96 to the City of Sierra Madre's spreading facility during the report period.

## **COASTAL PLAIN**

The groundwater basins underlying the Coastal Plain are divided by geological features into the Central (includes the Montebello and Los Angeles Forebays), West Coast, Santa Monica, and Hollywood Basins. During 1994-95, the Department recharged 101,185 acre-feet of local water, 21,500 acre-feet of imported water, and 33,300 acre-feet of reclaimed water to the groundwater basins underlying the Coastal Plain. Most of the water was spread in the Montebello Forebay.

During 1995-96, the Department recharged 64,840 acre-feet of local water, 17,890 acre-feet of imported water, and 53,867 acre-feet of reclaimed water in the Montebello Forebay.

## **Central Basin**

The Central Basin has the most storage capacity of the basins in the Coastal Plain. In addition to the water recharged in the Department's spreading facilities, water injected in the Alamitos Barrier Project also contributes to the replenishment of the pressure aquifers underlying the Central Basin.

During 1994-96 water year, the Department cleaned out the water conservation pool in the Whittier Narrows Flood Control Basin. The project entailed excavation of 837,700 C.Y. of sediment to restore the pool's 2,500 acre-feet capacity. This conservation pool provides storage for ultimate spreading in the Rio Hondo Coastal Basin Spreading Grounds.

## **West Coast Basin**

The West Coast Basin is the second largest basin underlying the Coastal Plain and is separated from the Central Basin by the Newport-Inglewood Fault zone. Groundwater is primarily recharged by Central Basin subsurface flows and by water injected by the Department in the West Coast Basin and Dominguez Gap Barrier Projects. Groundwater elevations in the West Coast Basin are below sea level except in the area of the West Coast Basin Barrier injection mound.

## **Santa Monica and Hollywood Basins**

The Department has no spreading facilities in either the Santa Monica or Hollywood groundwater

basins.

### SAN FERNANDO VALLEY

The San Fernando Valley is also called the Upper Los Angeles River Area (ULARA). Most of the runoff from the surrounding mountains flows to the Valley.

#### **San Fernando Main Basin**

The basin is the largest basin underlying the San Fernando Valley. The Department spread 69,108 acre-feet during 1994-95 and 21,240 acre-feet during 1995-96 of local water and no imported water were spread by the Department. The County entered into an agreement with the City of Los Angeles to spread water at the newly renovated Tujunga Wash Spreading Grounds which is located approximately two miles downstream of Hansen Spreading Grounds. The City installed a rubber dam diversion and appurtenant facilities for County Spreading operations which started in March 1990.

#### **Sylmar Basin**

A much smaller basin underlying the San Fernando Valley is the Sylmar Basin; the Department has no spreading facility within this basin.

#### **Verdugo and Eagle Rock Basins**

The small Verdugo and Eagle Rock Basins comprise the remaining basins underlying the San Fernando Valley. The Department has no spreading facilities within either basin.

### SANTA CLARITA VALLEY

The Department has no spreading facilities in the area. Much of the Valley is open space, permitting substantial natural percolation.

The Upper Santa Clarita subunit comprises five basins.

### ANTELOPE VALLEY

There are several groundwater subbasins underlying the Antelope Valley. Five of them are located within Los Angeles County.

The Department operates no spreading facilities in the Antelope Valley.

The hydrographs for Well Nos. 9974 and 8825 are shown on pages G32 and G33. They are located in the Lancaster and Little Rock subbasins respectively.



**LOS ANGELES COUNTY DEPARTMENT OF PUBLIC WORKS  
HYDRAULIC/WATER CONSERVATION DIVISION**

**SUMMARY OF DATA ON SPREADING FACILITIES  
OWNED AND OPERATED BY THE DEPARTMENT  
UPDATED THROUGH SEPTEMBER 1996**

SPREADING FACILITY	TYPE	SEASON FIRST USED	AREA (ACRES)		CAPACITIES				LOCATION	SOURCE OF WATER	REMARKS
			GROSS	WETTED	CHANNEL** (CFS)	INTAKE (CFS)	STORAGE (A.F.)	PERCOLATION* (CFS)			
ARROYO SECO	SHALLOW BASINS	1948-49	24	15.1	-	75	30	18	EASTERLY SIDE OF ARROYO SECO, 0.5 MILES ABOVE DEVIL'S GATE DAM.	CONTROLLED FLOW FROM CITY OF PASADENA. UNCONTROLLED FLOW FROM ARROYO SECO AND THE ALTADENA STORM DRAIN.	SPREADING GROUNDS ARE HELD UNDER EASEMENT FROM THE CITY OF PASADENA.
BEN LOMOND	SHALLOW BASINS	1958-59	24	17.0	-	25	25	18	BOTH NORTH AND SOUTH SIDES OF SAN DIMAS WASH CHANNEL AT SOUTHWESTERLY CORNER OF INTERSECTION OF ARROW HIGHWAY AND BARRANCA AVENUE.	COVINA IRRIGATING COMPANY.	SPREADING GROUNDS UTILIZED TO CONSERVE EXCESS COVINA IRRIGATION COMPANY WATER RELEASED FROM THE COMMITTEE OF NINE.
BIG DALTON	SHALLOW BASINS	1930-31	24	7.7	-	45	12	12	WESTERLY SIDE OF BIG DALTON WASH, ONE HALF MILE ABOVE SIERRA MADRE AVENUE.	CONTROLLED FLOWS FROM BIG DALTON DAM AND BIG DALTON DEBRIS BASIN.	
BRANFORD	DEEP BASIN	1956-57	12	7.0	1,540	1,540	137	1	SOUTHWESTERLY OF ARLETA AVENUE ABOVE CONFLUENCE OF TUJUNGA WASH AND PACOIMA DIVERSION CHANNEL.	UNCONTROLLED FLOWS FROM BRANFORD STREET DRAIN.	INSTREAM SPREADING FACILITY. OUTLET CAPACITY 1,540 CFS TO PACOIMA DIVERSION CHANNEL.
BUENA VISTA	DEEP BASIN	1954-55	10	6.0	2,900	2,900	177	6	1.0 MILE EASTERLY OF SAWPIT WASH. 0.5 MILE NORTHERLY OF ARROW HIGHWAY, BETWEEN MERIDIAN STREET AND BUENA VISTA CHANNEL.	CONTROLLED FLOW FROM SANTA FE DAM AND UNCONTROLLED FLOW FROM BUENA VISTA CHANNEL.	INSTREAM SPREADING FACILITY. TOTAL OUTLET CAPACITY OF 270 CFS.
CITRUS	SHALLOW BASINS	1960-61	19	14.6	11,000	245	80	28	SOUTH SIDE OF BIG DALTON WASH BETWEEN CITRUS AND CERRITOS AVENUES.	CONTROLLED FLOWS FROM BIG DALTON DAM AND LITTLE DALTON DEBRIS DAMS. UNCONTROLLED FLOWS FROM BIG DALTON WASH.	THERE ARE 2 INTAKES, ONE IS A DROP INLET, THE OTHER AN AIR INFLATED RUBBER DAM.
DOMINGUEZ GAP	DEEP BASINS	1957-58	54	23.8	-	20	234	1	SOUTH OF DEL AMO BOULEVARD AND BORDERS THE EASTERN AND WESTERN SIDES OF THE LOS ANGELES RIVER	CONTROLLED FLOW FROM LOS ANGELES RIVER LOW FLOW CHANNEL AND UNCONTROLLED FLOWS FROM STORM DRAINS.	EAST SIDE BASIN USED FOR FLOOD REGULATION WITH SOME CONSERVATION STORAGE. INTAKE CAPACITY IS 20 CFS FOR LOW FLOW DIVERSION FROM THE LOS ANGELES RIVER. THE WEST SIDE BASIN IS FED BY A 24-INCH CONCRETE PIPE FROM THE EAST SIDE BASIN.

\* THE CAPACITIES LISTED ARE ESTIMATES OF INFILTRATION RATES. NUMBERS DO NOT REFLECT LONG TERM SPREADING OPERATIONS.

\*\* DESIGN CAPACITY OF MAIN CHANNEL



**LOS ANGELES COUNTY DEPARTMENT OF PUBLIC WORKS  
HYDRAULIC/WATER CONSERVATION DIVISION**

**SUMMARY OF DATA ON SPREADING FACILITIES  
OWNED AND OPERATED BY THE DEPARTMENT  
UPDATED THROUGH SEPTEMBER 1996**

SPREADING FACILITY	TYPE	SEASON FIRST USED	AREA (ACRES)		CAPACITIES				LOCATION	SOURCE OF WATER	REMARKS
			GROSS	WETTED	CHANNEL** (CFS)	INTAKE (CFS)	STORAGE (A.F.)	PERCOLATION* (CFS)			
EATON BASIN	DEEP BASIN	1956-57	16	10.5	9,500	400	284	10	EAST SIDE OF EATON WASH, NORTH OF DUARTE ROAD, 0.6 MILES SOUTH OF HUNTINGTON DRIVE.	CONTROLLED FLOW FROM EATON WASH DAM AND UNCONTROLLED FLOWS BETWEEN DAM AND SPREADING BASIN.	
EATON WASH	DEEP & SHALLOW BASINS	1947-48	28	25.4	6,600	200	525	14	EASTERLY SIDE OF EATON WASH FROM BELOW EATON DAM TO FOOTHILL BOULEVARD.	CONTROLLED FLOW FROM EATON WASH DAM. IMPORTED WATER CAN BE SPREAD IN STRIP BASINS.	
FORBES	SHALLOW BASINS	1964-65	21	10	-9,000	100	87	5	SOUTH SIDE OF SAN DIMAS WASH BETWEEN LONE HILL AVENUE AND VALLEY CENTER AVENUE.	CONTROLLED RELEASES FROM PUDDINGSTONE DIVERSION DAM, AND UNCONTROLLED FLOWS FROM SAN DIMAS WASH; ALSO IMPORTED .	
HANSEN	SHALLOW BASINS	1944-45	156	105.3	22,000	400	279	150	NORTHWESTERLY SIDE OF TUJUNGA WASH FROM ABOVE GLENOAKS BOULEVARD SOUTHWESTERLY TO SAN FERNANDO ROAD.	CONTROLLED FLOWS FROM HANSEN DAM AND BIG TUJUNGA DAM.	
IRWINDALE\MANNING PIT	DEEP BASINS	1958-59	62	30	25,500	400	1134	60	NORTHEASTERLY OF INTERSECTION OF BIG DALTON CHANNEL AND IRWINDALE AVENUE; CONTINUES 1,300 FEET EAST OF IRWINDALE VENUE	BIG DALTON CHANNEL CONTROLLED FLOWS FROM BIG AND LITTLE DALTON DEBRIS DAMS AND PUDDINGSTONE DIVERSION DAM; UNCONTROLLED FLOWS; ALSO IMPORTED RELEASES .	IRWINDALE CLEANED OUT SUMMER OF 1996.
LITTLE DALTON	SHALLOW BASINS	1931-32	14	4.7	-	20	5	15	WESTERLY OF GLENDORA MT. ROAD FROM LITTLE DALTON DEBRIS BASIN SOUTH TO EAST PALM DRIVE.	CONTROLLED FLOW FROM LITTLE DALTON DEBRIS BASIN AND IMPORTED WATER. (IMPORTED WATER DELIVERY COMMENCED IN OCTOBER 1995).	
LIVE OAK	SHALLOW BASINS	1961-62	5	2.2	-	15	2	13	WESTERLY SIDE OF LIVE OAK WASH. NORTH OF BASE LINE ROAD (PROJECTED).	CONTROLLED FLOW FROM LIVE OAK DAM AND LIVE OAK DEBRIS BASIN	
LOPEZ	SHALLOW BASINS	1956-57	18	2.211.9	-	25	23.6	15	SOUTHEASTERLY SIDE OF PACOIMA WASH, NORTHEASTERLY OF FOOTHILL BOULEVARD.	CONTROLLED FLOW FROM PACOIMA DAM AND LOPEZ FLOOD CONTROL BASIN	

\* THE CAPACITIES LISTED ARE ESTIMATES OF INFILTRATION RATES. NUMBERS DO NOT REFLECT LONG TERM SPREADING OPERATIONS.

\*\* DESIGN CAPACITY OF MAIN CHANNEL

**LOS ANGELES COUNTY DEPARTMENT OF PUBLIC WORKS  
HYDRAULIC/WATER CONSERVATION DIVISION**

**SUMMARY OF DATA ON SPREADING FACILITIES  
OWNED AND OPERATED BY THE DEPARTMENT  
UPDATED THROUGH SEPTEMBER 1996**

SPREADING FACILITY	TYPE	SEASON FIRST USED	AREA (ACRES)		CAPACITIES				LOCATION	SOURCE OF WATER	REMARKS
			GROSS	WETTED	CHANNEL** (CFS)	INTAKE (CFS)	STORAGE (A.F.)	PERCOLATION* (CFS)			
PACOIMA	SHALLOW BASINS	1932-33	169	107.3	17,000	600	440	65	BOTH SIDES OF OLD PACOIMA WASH CHANNEL FROM ARLETA AVENUE SOUTHWESTERLY TO WOODMAN AVENUE.	CONTROLLED FLOW FROM PACOIMA DAM. PARTIALLY CONTROLLED FLOW FROM LOPEZ FLOOD CONTROL BASIN, UNCONTROLLED FLOW FROM EAST CANYON AND PACOIMA WASH AND IMPORTED WATER.	
PECK ROAD	DEEP BASIN	1959-60	157	105	30,100	30,100	3,347	25	CONFLUENCE OF SAWPIT AND SANTA ANITA WASHES.	CONTROLLED RELEASES FROM SANTA ANITA AND SAWPIT DEBRIS BASINS AND UNCONTROLLED FLOWS FROM LOCAL RUNOFF VIA SAWPIT AND SANTA ANITA WASHES.	INSTREAM SPREADING FACILITY.
RIO HONDO COASTAL	SHALLOW BASINS	1937-38	570	430.1	40,000	1,950	3,694	400	EASTERLY SIDE OF RIO HONDO SOUTHERLY FROM S. P. R. R. (SOUTH OF WHITTIER BLVD.) TO SLAUSON AVENUE; WEST SIDE OF RIO HONDO CHANNEL FROM 0.2 MILE ABOVE WHITTIER BOULEVARD SOUTH TO FOSTER BRIDGE BOULEVARD.	CONTROLLED RELEASES FROM SAN GABRIEL CANYON DAMS, SANTA FE AND WHITTIER NARROWS DAMS. UNCONTROLLED RUNOFF VIA SAN GABRIEL RIVER, RIO HONDO CHANNEL AND THEIR TRIBUTARIES; ALSO IMPORTED AND RECLAIMED WATER.	IN COOPERATION WITH THE CORPS OF ENGINEERS. THE DISTRICT OPERATES 2,500 ACRE-FOOT POOL AT WHITTIER NARROWS DAM FOR RETENTION OF STORM WATER.
SAN DIMAS CANYON	SHALLOW BASINS	1965-66	22	10.8	-	25	22	12	SOUTHEAST SIDE OF SAN DIMAS WASH BETWEEN PUDDINGSTONE DIVERSION AND SAN DIMAS CANYON ROAD.	CONTROLLED RELEASES FROM PUDDINGSTONE DIVERSION DAM; UNCONTROLLED FLOW FROM LOCAL STORM RUNOFF.	
SAN GABRIEL CANYON	DEEP BASINS	1917	165	-	98,000	475	8170	35	EASTERLY SIDE OF SAN GABRIEL RIVER. BELOW MOUTH OF SAN GABRIEL CANYON. NORTH OF THE CITY OF AZUSA.	SAN GABRIEL RIVER CONTROLLED RELEASES FROM COGSWELL DAM, SAN GABRIEL DAM, AND MORRIS DAM. COMMITTEE OF NINE SURPLUS FLOWS AND IMPORTED WATER.	THERE ARE 2 INTAKES TO THIS FACILITY, ONE IS FED FROM SURPLUS 'COMMITTEE OF NINE' FLOWS, THE OTHER IS FROM THE RIVER INTO BASIN NO. 2.
SAN GABRIEL COASTAL	SHALLOW BASINS	1938-39	128	95.9	20,000	350	550	75	WESTERLY SIDE OF SAN GABRIEL RIVER, SOUTHERLY FROM WHITTIER BOULEVARD TO WASHINGTON BOULEVARD.	CONTROLLED RELEASES FROM SAN GABRIEL CANYON DAMS, SANTA FE AND WHITTIER NARROWS DAMS. ALSO IMPORTED AND RECLAIMED WATER.	

\* THE CAPACITIES LISTED ARE ESTIMATES OF INFILTRATION RATES. NUMBERS DO NOT REFLECT LONG TERM SPREADING OPERATIONS.

\*\* DESIGN CAPACITY OF MAIN CHANNEL

**LOS ANGELES COUNTY DEPARTMENT OF PUBLIC WORKS  
HYDRAULIC/WATER CONSERVATION DIVISION**

**SUMMARY OF DATA ON SPREADING FACILITIES  
OWNED AND OPERATED BY THE DEPARTMENT  
UPDATED THROUGH SEPTEMBER 1996**

SPREADING FACILITY	TYPE	SEASON FIRST USED	AREA (ACRES)		CAPACITIES				LOCATION	SOURCE OF WATER	REMARKS
			GROSS	WETTED	CHANNEL** (CFS)	INTAKE (CFS)	STORAGE (A.F.)	PERCOLATION* (CFS)			
SAN GABRIEL RIVER (MONTEBELLO FOREBAY)	SHALLOW BASINS	1954-55	308	308	20,000	550	913	75	HEADWORKS TO FIRESTONE AVE. ONLY. STORAGE BEHIND THE SEVEN RUBBER DAMS INSTALLED ON DROP STRUCTURE.	SAME AS SAN GABRIEL COASTAL.	
SAN GABRIEL RIVER (SAN GABRIEL VALLEY)		1965-66	196	196	41,000 TO 98,000	-	-	180	SAN GABRIEL RIVER FROM SANTA FE DAM TO WHITTIER NARROWS DAM.	CONTROLLED FLOW FROM DAMS IN SAN GABRIEL CANYON, SANTA FE DAM AND UNCONTROLLED VALLEY RUNOFF BELOW SANTA FE DAM; ALSO IMPORTED WATER.	
SANTA ANITA	SHALLOW BASINS	1944-45	20	8.5	-	20	25	5	WESTERLY SIDE OF SANTA ANITA WASH 1.25 MILES ABOVE FOOTHILL BOULEVARD.	CONTROLLED FLOW FROM SANTA ANITA DAM AND SANTA ANITA DEBRIS BASIN.	THE HEADWORKS LOCATED UPSTREAM OF THE DEBRIS BASIN DIVERTS WATER TO SANTA ANITA SPREADING GROUNDS AND CITY OF SIERRA MADRE SPREADING GROUNDS
SANTA FE	SHALLOW BASINS	1953-54	338	168	98,000	500	540	400	WITHIN SANTA FE DAM RESERVOIR AND SPILLWAY AREAS.	CONTROLLED FLOWS FROM SAN GABRIEL CANYON RESERVOIRS. UNCONTROLLED FLOWS FROM SAN GABRIEL RIVER BELOW MORRIS RESERVOIR; ALSO IMPORTED WATER.	NEW DIVERSION HEADWORKS STRUCTURE CONSTRUCTED, CONSISTING OF A NEW RUBBER DAM AND 2 INTAKES GATES.
SA WPIT	SHALLOW BASINS	1946-47	12	3.8	-	30	13	12	WESTERLY SIDE OF SA WPIT WASH BELOW MOUTH OF CANTON NEAR NORUMBEGA DRIVE, MONROVIA.	CONTROLLED FLOWS FROM SAWPIT DAM AND SAWPIT DEBRIS BASIN.	
VALLY BLVD. RUBBER DAM	SHALLOW BASIN	1994-95	60	60	60,000	-	400	UNKNOWN	DROP STRUCTURE SOUTH OF VALLY BLVD, AT THE CONFLUENCE OF THE SAN GABRIEL RIVER AND WALNUT CREEK.	SAME AS FORBES AND IRWINDALE/MANNING PIT CAN ALSO RECEIVE RELEASE FROM SAN GABRIEL CANYON RERSERVOIRS AND IMPORTED WATER.	
WALNUT	DEEP BASIN	1962-63	16	8.1	8,000	150	170.5	5	WEST SIDE OF WALNUT WASH, NORTH OF SAN BERNARDINO FREEWAY.	CONTROLLED FLOW FROM PUDDINGSTONE DAM AND UNCONTROLLED FLOWS FROM WALNUT CREEK.	BASIN CLEANED OUT SUMMER OF 1995.

\* THE CAPACITIES LISTED ARE ESTIMATES OF INFILTRATION RATES.  
NUMBERS DO NOT REFLECT LONG TERM SPREADING OPERATIONS.

\*\* DESIGN CAPACITY OF MAIN CHANNEL

LOS ANGELES COUNTY DEPARTMENT OF PUBLIC WORKS  
HYDRAULIC/WATER CONSERVATION DIVISION

SUMMARY OF DATA ON SPREADING FACILITIES  
NOT OWNED BY THE DEPARTMENT  
UPDATED THROUGH SEPTEMBER 1996

SPREADING FACILITY	TYPE	SEASON FIRST USED	AREA (ACRES)		CAPACITIES				LOCATION	SOURCE OF WATER	REMARKS
			GROSS	WETTED	CHANNEL** (CFS)	INTAKE (CFS)	STORAGE (A.F.)	PERCOLATION* (CFS)			
SIERRA MADRE (CITY OF, SIERRA MADRE)	SHALLOW BASINS	ABOUT 1933	22	9.0	-	25	47	15	CITY OF SIERRA MADRE, SOUTH SIDE OF GRANDVIEW AVENUE, ONE HALF MILE WEST OF SANTA ANITA AVENUE	LITTLE SANTA ANITA CREEK AND STREET RUNOFF ALSO CONTROLLED FLOWS FROM SANTA ANITA DAM.	THE DEPARTMENT DIVERTS WATER TO THIS FACILITY VIA SANTA ANITA HEADWORKS.
FISH CANYON (COMMITTEE OF NINE)	SHALLOW BASINS	ABOUT 1917	6	4.0	-	-	-	7	WESTERLY SIDE OF SAN GABRIEL RIVER BELOW MOUTH OF FISH CANYON AND NORTH OF THE CITY OF AZUSA.	THE 'COMMITTEE OF NINE'.	OWNED AND OPERATED BY CAL-AMERICAN WATER COMPANY.
THOMPSON CREEK **** POMONA VALLEY PROTECTIVE ASSOCIATION	DITCHES CHECKS AND DEEP BASIN	ABOUT 1928	53	37.0	-	35	-	15	SOUTHERLY FROM, AND ADJACENT TO THOMPSON CREEK DAM, EAST SIDE OF CREEK.	COBAL, WILLIAMS, PALMER, AND PADUA CREEKS, ALSO THOMPSON CREEK, WHEN RESERVOIR ABOVE ELEVATION 1,625.	OPERATED BY POMONA VALLEY PROTECTIVE ASSOCIATION. THE DEPARTMENT DIVERTS WATER TO THIS FACILITY VIA THE PALMER DIVISION.
TUJUNGA (L.A. CITY DEPT. OF WATER AND POWER) ***	SHALLOW BASINS	ABOUT 1931-32	188	83.2	22,000	400	100	120	SAN FERNANDO VALLEY, EAST SIDE OF TUJUNGA WASH AT ROSCOE BOULEVARD.	CONTROLLED RELEASES FROM BIG TUJUNGA DAM, HANSEN DAM AND UNCONTROLLED RUNOFF FROM STORM DRAINS. ALSO IMPORTED WATER.	THE DEPARTMENT HAS AN AGREEMENT WITH THE CITY OF LOS ANGELES TO OPERATE THIS FACILITY.
	TOTALS:		269	133.2	-	-	147	157			

\* THE CAPACITIES LISTED ARE ESTIMATES OF INFILTRATION RATES.

\*\* DESIGN CAPACITY OF MAIN CHANNEL.

Los Angeles County, Department of Public Works, Hydraulic / Water Conservation Division  
**TOTAL MONTHLY WATER CONSERVED DURING WATER YEAR 1994-95**

AREA	SPREADING FACILITIES	OCT	NOV	DEC	JAN	FEB	MAR	APR	MAY	JUN	JUL	AUG	SEP	ACC. TOT
SAN FERNANDO VALLEY	BRANFORD	34	56	70	105	60	60	81	21	47	22	17	12	585
	HANSEN	425	387	466	5,950	4,560	9,930	6,950	1,640	2,100	1,480	868	381	35,137
	LOPEZ	0	0	0	3	217	100	472	199	90	1	3	0	1,086
	PACOIMA	0	34	109	3,280	2,190	3,740	3,080	876	480	101	46	128	14,064
	TUJUNGA	0	6	70	4,558	2,675	3,120	2,914	4,030	787	0	0	76	18,235
	SUBTOTAL	460	483	715	13,896	9,702	16,950	13,497	6,766	3,504	1,604	935	597	69,108
SAN GABRIEL VALLEY	ARROYO SECO	7	41	83	889	1,050	910	1,160	934	535	69	0	0	5,678
	BEN LOMOND	127	182	186	153	237	219	264	135	352	606	82	332	2,875
	BIG DALTON	0	0	0	185	24	18	94	32	171	113	9	28	674
	BUENA VISTA	25	14	0	129	45	37	0	0	0	0	0	0	250
	CITRUS	83	105	77	427	828	1,662	991	905	530	279	483	107	6,478
	EATON BASIN	25	31	45	288	52	378	291	135	78	60	18	44	1,445
	EATON GROUNDS	0	0	0	526	675	827	887	332	109	75	28	0	3,459
	FORBES	2	0	122	202	103	161	39	0	64	176	279	209	1,357
	IRWINDALE	227	1	808	1,440	1,300	1,290	439	509	946	550	903	752	9,165
	LITTLE DALTON	0	0	0	235	315	599	376	80	113	30	13	5	1,766
	LIVE OAK	0	0	0	29	122	0	37	101	132	4	12	0	437
	MORRIS TO STA. F190	1,039	1,680	2,300	6,102	4,138	8,664	7,290	5,215	1,526	5,135	746	384	44,219
	STA. F190 TO S.F. DAM OUTFLO	836	1,156	1,834	1,888	2,236	3,095	3,760 *	2,000 *	1,010	1,937	300	0	20,050
	PECK ROAD	152	592	302	2,328	2,056	1,131	1,991	1,353	605	95	84	70	10,759
	SAN DIMAS CANYON	0	0	1	429	722	754	767	928	668	771	509	6	5,555
	SAN GABRIEL CANYON	10	1,980	1,650	476	1,248	818	1,960	1,307	990	2,300	732	354	13,825
	SANTA ANITA	0	0	0	196	202	116	126	156	74	49	32	4	956
	SANTA FE SPRD. GROUNDS	0	0	0	3,529	12,698	8,630	17,530	5,996	10	5,877	1,980	0	56,250
	SANTA FE TO STA. F263	2,062	2,095	8,695	3,957	3,898	5,608	576	11,785	6,479	7,306	1,100	0	53,561
SANTA FE DIVERSION	16	104	419	305	346	72	66	412	103	0	0	0	1,841	
SAWPIT	55	58	51	232	493	430	311	316	301	284	8	0	2,539	
WALNUT	170	71	96	158	322	77	185	1	0	(18) #	(14) #	0	1,047	
	SUBTOTAL	4,836	8,110	16,669	24,103	33,109	35,496	39,140	32,631	14,795	25,698	7,304	2,295	244,190
COASTAL PLAIN	RIO HONDO EAST FLUME	857	2,680	2,820	6,950	4,250	3,870	1,370	3,510	3,680	32	146	678	30,843
	WEST FLUME	1,370	0	474	2,490	1,540	866	572	442	689	190	68	9	8,710
	R/W FLUME	125	3	3	227	82	593	253	17	7	0	0	0	1,310
	102" INTAKE	728	3,184	3,513	4,124	1,386	2,422	3,306	970	1,293	0	0	0	20,926
	RIO HONDO VICINITY	1,520	2,505	2,825	3,914	3,354	2,908	1,454	1,670	1,727	198	401	210	22,686
	SAN GABRIEL SYSTEM	6,268	3,437	5,669	10,729	6,975	12,500	4,695	5,093	2,817	6,695	4,019	2,343	71,240
	DOMINGUEZ GAP	7	44	16	0	0	91	13	0	0	70	0	29	270
		SUBTOTAL	10,875	11,853	15,320	28,434	17,587	23,250	11,664	11,702	10,213	7,185	4,634	3,269
OTHER FACILITIES	SIERRA MADRE	0	0	0	224	187	151	333	442	500	437	185	0	2,459
	FISH CREEK	182	155	139	89	311	311	531	815	785	873	849	775	5,813
		SUBTOTAL	182	155	139	313	498	462	864	1,257	1,285	1,310	1,034	775
<b>TOTAL OF ALL WATER CONSERVED</b>		<b>16,352</b>	<b>20,600</b>	<b>32,843</b>	<b>66,746</b>	<b>60,897</b>	<b>76,157</b>	<b>65,165</b>	<b>52,356</b>	<b>29,797</b>	<b>35,796</b>	<b>13,906</b>	<b>6,936</b>	<b>477,550</b>

# : Water pumped out from grounds due to basin cleanout.

\* : Estimated

⊕ - rounded values to the nearest 10.

: Water spread at Little Dalton during Sept. was a test for the new TVMWD outlet.

Los Angeles County, Department of Public Works  
Hydraulic Water Conservation Division

**Imported and Reclaimed Water Delivered in Acre-Feet  
WATER YEAR : 1994-1995**

MONTH	IMPORTED WATER OUTLET RELEASES									RECLAIMED WATER DELIVERED									
	SAN DIMAS	THOMPSON CREEK	SAN GAB. RIVER	ALHAMBRA	OLDEN ST	USG 3	BEATTY CANYON	SAN DIMAS WH	MONTHLY TOTAL	WHITTIER NARROWS PLANT			SAN JOSE PLANT			POMONA	MONTHLY TOTAL		
	CB - 48	CB - 28	CB - 37	CB - 36	L.A. 699	USGMWD	SGVMWD	SGVMWD	SPREAD	DELIVERED		WASTED	MONTHLY	DELIVERED		WASTED	MONTHLY	PLANT	SPREAD
										R.HONDO	S.GABRIEL		SPREAD	R.HONDO	S.GABRIEL		SPREAD		
OCT	0.0	6,841.6	0.0	1,421.0	0.0	438.5	2,064.0	176.0	10,941.1	1,082.3	18.2	3.2	1,097.3	681.0	116.5	2.6	794.9	344.3	2,236.5
NOV	0.0	5,417.9	0.0	1,164.9	0.0	2,865.9	0.0	0.0	9,448.7	1,076.3	0.0	0.0	1,076.3	881.1	293.2	0.0	1,174.3	321.4	2,572.0
DEC	0.0	5,176.2	0.0	1,114.7	0.0	8,611.3	0.0	945.0	15,847.2	839.0	0.0	0.0	839.0	724.0	527.3	0.0	1,251.3	294.9	2,385.2
JAN	0.0	575.1	0.0	126.1	0.0	0.0	0.0	0.0	701.2	909.5	0.0	465.4	444.1	131.5	1,420.2	761.1	790.6	608.8	1,843.5
FEB	0.0	0.0	0.0	0.0	0.0	0.0	0.0	438.0	438.0	1,124.2	0.0	158.7	965.5	573.2	688.3	170.6	1,090.9	517.8	2,574.2
MAR	0.0	0.0	0.0	0.0	0.0	0.0	0.0	0.0	0.0	1,264.7	0.0	923.1	341.6	87.0	1,925.9	1,591.4	421.5	584.7	1,347.8
APR	0.0	0.0	0.0	0.0	0.0	0.0	0.0	0.0	0.0	1,288.3	0.0	28.0	1,260.3	281.7	1,624.2	6.6	1,899.3	465.8	3,625.4
MAY	0.0	0.0	0.0	0.0	0.0	0.0	0.0	489.0	489.0	1,310.4	0.0	0.0	1,310.4	519.5	1,292.1	0.0	1,811.6	360.9	3,482.9
JUN	0.0	0.0	0.0	0.0	0.0	0.0	0.0	1,133.0	1,133.0	1,200.7	37.0	22.0	1,215.7	1,422.7	1,480.0	0.0	2,902.7	214.8	4,333.2
JUL	0.0	0.0	0.0	0.0	0.0	0.0	0.0	1,715.0	1,715.0	0.0	924.7	0.0	924.7	71.8	2,699.3	42.0	2,729.1	154.8	3,808.6
AUG	0.0	0.0	0.0	0.0	0.0	0.0	0.0	1,239.0	1,239.0	0.0	589.1	0.0	589.1	5.2	2,714.7	290.0	2,429.9	42.0	3,061.0
SEP	0.0	0.0	0.0	0.0	0.0	0.0	0.0	1,081.0	1,081.0	192.3	385.5	0.0	577.8	730.5	1,897.1	1,493.0	1,134.6	317.4	2,029.8
<b>TOTALS</b>	<b>0.0</b>	<b>18,010.8</b>	<b>0.0</b>	<b>3,826.7</b>	<b>0.0</b>	<b>11,915.7</b>	<b>2,064.0</b>	<b>7,216.0</b>	<b>43,033.2</b>	<b>10,287.7</b>	<b>1,954.5</b>	<b>1,600.4</b>	<b>10,641.8</b>	<b>6,109.2</b>	<b>16,678.8</b>	<b>4,357.3</b>	<b>18,430.7</b>	<b>4,227.6</b>	<b>33,300.1</b>



Los Angeles County, Department of Public Works, Hydraulic / Water Conservation Division

TOTAL MONTHLY WATER CONSERVED DURING WATER YEAR 1995-96

AREA	SPREADING FACILITY	OCT	NOV	DEC	JAN	FEB	MAR	APR	MAY	JUN	JUL	AUG	SEP	ACC. TOT
San Fernand Valley	Branford	14	18	89	48	72	39	27	13	7	6	6	6	345
	Hansen	0	0	689	1,089	2,723	1,234	1,349	555	216	373	4	0	8,232
	Lopez	0	0	0	0	69	97	172	25	0	0	0	0	363
	Pacoima	0	0	61	250	1,544	2,172	505	0	0	0	0	0	4,532
	Tujunga†	372	497	277	26	1,740	3,250	0	750	336	0	255	264	7,767
	SUBTOTAL	386	515	1,116	1,413	6,148	6,792	2,053	1,343	559	379	265	270	21,240
San Gabriel Valley	Arroyo Seco	20	48	118	188	529	936	251	13	20	4	6	19	2,152
	Ben Lomond	444	585	589	520	294	712	221	461	216	293	270	284	4,889
	Big Dalton	0	0	30	0	129	417	207	69	20	0	0	0	872
	Buena Vista	0	0	19	79	21	27	0	0	0	0	0	0	146
	Citrus	18	128	41	166	259	454	589	124	8	71	29	10	1,897
	Eaton Basin	21	17	32	196	362	178	38	26	25	24	29	24	972
	Eaton Grounds	0	0	0	0	411	661	86	39	0	0	0	0	1,197
	Forbes	252	120	136	61	69	28	90	51	260	224	0	0	1,291
	Irwindale	748	925	447	211	544	222	950	70	911	1,009	-350 ‡	0	5,690 <sup>⊕</sup>
	Little Dalton	893	946	1	444	26	208	283	500	794	0	747	704	5,546
	Live Oak	3	0	1	0	39	176	7	36	1	0	0	0	263
	Morris to Sta. F190	2,310	510	460	445	917	2,620	1,480	3,300	4,950	3,850	5,160	5,950	31,952
	Sta. F190 to S. Fe Dam O/F	554	6	32	127	665	1,177	1,371	2,153	1,091	368	1,176	1,115	9,835
	Peck Road	3,007	116	264	882	880	345	275	320	2,769	43	1,511	726	11,138
	San Dimas Canyon	0	118	0	174	262	654	414	94	297	307	106	0	2,426
	San Gabriel Canyon	363	158	143	220	713	1,812	5,944	1,525	1,067	893	2,715	2,427	17,980
	Santa Anita	12	8	6	6	83	199	129	71	31	25	0	40	610
	Santa Fe SG	0	0	0	0	0	0	3,533	5,578	2,751	5,113	7,410	6,562	30,947
	Santa Fe to Sta. F263	830	488	200	515	2,970	2,466	840	1,139	1,539	2,022	1,595	1,477	16,081
	Santa Fe Diversion	0	0	0	0	0	0	0	10	0	34	286	210	540
Sawpit	0	0	0	0	102	42	183	145	124	101	76	30	803	
Walnut	0	0	0	0	316	133	0	91	93	85	63	84	865	
Sierra Madre†	170	78	84	119	172	497	462	254	115	87	0	100	2,138	
Fish Creek†	714	521	464	463	374	784	685	775	753	776	769	755	7,833	
	SUBTOTAL	10,359	4,772	3,068	4,816	10,137	14,748	18,038	16,844	17,835	15,329	21,600 <sup>⊕</sup>	20,517	158,060 <sup>⊕</sup>
Coastal Plain	Rio Hondo East flume	6,590	2,185	3,129	2,597	5,426	3,873	3,045	2,484	4,488	644	3,083	2,968	40,512
	West Flume	661	779	946	1,030	1,263	363	1,065	1,245	1,593	995	1,638	896	12,474
	R/W Flume	0	0	0	63	862	1,005	161	365	369	134	153	439	3,551
	102" Intake	595	629	460	2,505	4,028	2,805	1,744	383	2,846	1,250	1,242	2,860	21,347
	Rio Hondo Vicinity	584	486	256	1,110	2,580	2,392	470	186	3,266	559	957	1,076	13,922
	San Gabriel System	290	4,121	6,348	5,767	6,210	4,286	4,304	4,355	3,135	3,578	180	1,530	44,104
	Dominguez Gap	28	0	0	0	0	0	33	148	115	123	123	119	689
		SUBTOTAL	8,748	8,200	11,139	13,072	20,369	14,724	10,822	9,166	15,812	7,283	7,376	9,888
<b>Total Water Conserved</b>		<b>19,494</b>	<b>13,487</b>	<b>15,323</b>	<b>19,301</b>	<b>36,654</b>	<b>36,264</b>	<b>30,913</b>	<b>27,353</b>	<b>34,206</b>	<b>22,991</b>	<b>29,241</b>	<b>30,675</b>	<b>315,899</b>

† : Owned by other entities.

⊕ - rounded values to the nearest 10.

‡ : Water pumped out from grounds due to basin cleanout.

Los Angeles County, Department of Public Works  
Hydraulic Water Conservation Division

**Imported and Reclaimed Water Delivered in Acre-Feet  
WATER YEAR : 1995-1996**

	IMPORTED WATER OUTLET RELEASES											RECLAIMED WATER DELIVERED										
	San Dimas	Thompson Creek	San Gabriel River	Alhambra	Olden Street	TVMWD Little Dalton	USG 3 USGMWD	SGVMWD			Waste to the Ocean	MONTHLY TOTAL SPREAD	WHITTIER NARROWS PLANT			SAN JOSE PLANT			MONTHLY TOTAL SPREAD			
	CB - 48	CB - 28	CB - 37	CB - 36	L.A. 699	PM26	USGMWD	Beatty Canyon	San Dimas	SG Canyon Basin 1			DELIVERED	WASTED	MONTHLY SPREAD	DELIVERED	WASTED	MONTHLY SPREAD		Pomona Plant		
													Rio Hondo	San Gabriel		Rio Hondo	San Gabriel					
OCT	0.0	0.0	0.0	0.0	0.0	850.0	0.0	0.0	1,004.0	0.0	0.0	1,854.0	683.0	0.0	0.0	683.0	1,928.8	0.0	0.0	1,928.8	288.6	2,900.4
NOV	0.0	0.0	0.0	1,052.8	0.0	967.4	0.0	0.0	1,114.0	0.0	0.0	3,134.2	1,152.6	0.0	0.0	1,152.6	1,310.9	3,705.9	0.0	5,016.8	350.1	6,519.5
DEC	0.0	8.0	0.0	722.2	0.0	1.5	0.0	0.0	644.0	0.0	0.0	1,375.7	981.7	0.0	0.0	981.7	1,297.9	4,446.9	0.0	5,744.8	427.1	7,153.6
JAN	0.0	0.0	0.0	1,389.9	0.0	443.1	0.0	0.0	0.0	0.0	0.0	1,833.0	873.9	0.0	50.0	823.9	1,362.5	3,508.7	56.9	4,814.3	394.1	6,032.3
FEB	0.0	0.0	0.0	0.0	0.0	0.0	0.0	0.0	0.0	0.0	0.0	0.0	1,118.5	0.0	152.6	965.9	1,483.1	2,382.1	370.7	3,494.5	490.6	4,951.0
MAR	0.0	0.0	0.0	0.0	0.0	0.0	0.0	0.0	0.0	0.0	0.0	0.0	1,038.7	0.0	82.4	956.3	1,122.5	1,441.4	138.9	2,425.0	520.3	3,901.6
APR	0.0	2,772.8	0.0	1,167.7	0.0	279.9	7,693.6	0.0	953.0	1,572.0	0.0	14,439.0	931.3	0.0	29.8	901.5	382.7	1,553.7	6.1	1,930.3	180.7	3,012.5
MAY	0.0	2,463.0	0.0	1,797.9	0.0	476.0	7,859.4	0.0	1,420.0	0.0	0.0	14,016.3	1,086.9	0.0	0.0	1,086.9	1,084.1	988.0	0.0	2,072.1	118.4	3,277.4
JUN	0.0	398.8	0.0	1,913.0	0.0	802.5	0.0	0.0	1,765.0	588.0	0.0	5,467.3	290.7	130.5	0.0	421.2	404.5	2,342.2	0.0	2,746.7	69.1	3,237.0
JUL	0.0	0.0	0.0	1,575.6	0.0	0.0	8,247.1	0.0	1,934.0	645.0	0.0	12,401.7	657.8	0.0	0.0	657.8	1,184.0	3,512.8	0.0	4,696.8	48.9	5,403.5
AUG	0.0	0.0	0.0	1,393.6	0.0	747.0	10,685.0	922.0	0.0	2,484.0	0.0	16,231.6	645.8	0.0	0.0	645.8	3,886.6	0.0	0.0	3,886.6	30.0	4,562.4
SEP	0.0	0.0	0.0	1,341.9	0.0	704.1	8,824.8	862.0	0.0	2,468.0	0.0	14,200.8	409.1	285.7	0.0	694.8	921.4	1,243.8	0.0	2,165.2	55.7	2,915.7
<b>TOT</b>	<b>0.0</b>	<b>5,642.6</b>	<b>0.0</b>	<b>12,354.6</b>	<b>0.0</b>	<b>5,271.5</b>	<b>43,309.9</b>	<b>1,784.0</b>	<b>8,834.0</b>	<b>7,757.0</b>	<b>0.0</b>	<b>84,953.6</b>	<b>9,870.0</b>	<b>416.2</b>	<b>314.8</b>	<b>9,971.4</b>	<b>16,369.0</b>	<b>25,125.5</b>	<b>572.6</b>	<b>40,921.9</b>	<b>2,973.6</b>	<b>53,866.9</b>

12-Nov-96

NOTES: - All PM 26 deliveries during October thru December 1995, January, April, May, and June 1996 for MWD cyclic storage.  
- CB28 release in December 1995 to flush the MWD pipeline.

## WELL HYDROGRAPHS INCLUDED IN THIS REPORT

GROUNDWATER BASIN	WELL NO.	APPROXIMATE LOCATION	PAGE NO.
WEST COAST	1346D 760C	11305 TRURO AVE., 250FT. N. OF IMPERIAL HWY., COMPTON 99 FT. S.W. OF INTERSECTION OF COMPTON BLVD. & DOTY AVE., LAWNSDALE	G21
CENTRAL BASIN	460K	2,600 FT. N.E. OF THE INTERSECTION OF LAKEWOOD BLVD. & PACIFIC COAST HWY., LONG BEACH	G22
	1601T	1,000 FT. S. OF THE INTERSECTION OF WASHINGTON BLVD. & ROSEMEAD BLVD., MONTEBELLO	G23
	906D	1,300 FT. N.W. OF THE INTERSECTION OF LONG BEACH & SAN ANTONIO DR., LONG BEACH	G24
MAIN SAN GABRIEL	3030F	600 FT. N.W. OF THE INTERSECTION OF LOS ANGELES ST. & MAINE AVE., BALDWIN PARK	G25
	2965C	100 FT. S.W. OF THIENES AVE. & 180 FT. N.W. OF DURFEE AVE. (NOW PECK ROAD)	G26
SAN GABRIEL CANYON	4284A	5,600 FT. N.W. OF THE INTERSECTION OF SIERRA MADRE AVE. & SAN GABRIEL CANYON ROAD., AZUSA	G27
	4285	2,700 FT. N.W. OF SAN GABRIEL CANYON RD. & SIERRA MADRE AVE.	
POMONA	3251E	2,200 FT. N. OF THE INTERSECTION OF SAN BERNARDINO FWY. & TOWNE AVE., POMONA	G28
	3261P	630 FT. N.E. FROM INTERSECTION OF LA VERNE AVE. & 50 FT. S.E. OF CENTERLINE OF TOWNE AVE.	
	4469A	739 FT. W. OF MOUNTAIN AVE., 1,025 FT. N. OF HARRISON AVE.	
CLAREMONT HEIGHTS	4508B	800 FT. S.E. OF THE INTERSECTION OF BASELINE RD. & PADUA AVE., CLAREMONT	G29
	4508A	270 FT. N.W. OF WELL 4508	
RAYMOND	4057H	LOS ROBLES & GLENARM STREETS, PASADENA	G30
SANTA CLARA	7048A	S.E. OF THE INTERSECTION OF NEWHALL AVE. & MAGIC MOUNTAIN PARKWAY, SAUGUS	G31
	7048C	544 FT. W. OF W. CURB OF VALENCIA BLVD., 56 FT. S. OF MAGIC MOUNTAIN PARKWAY, VALENCIA	
ANTELOPE VALLEY	9974	8,976 FT. S. OF AVE. K & 200 FT. W. OF SIERRA HWY., LANCASTER	G32
	8825	25 FT. N. OF AVE. T & 45 FT. E. OF 90TH ST., LITTLE ROCK	G33
MAIN SAN FERNANDO	3872H	CLARK AVE. & GRIFFITH PARK DR., BURBANK	G34
	4709	SHERMAN WAY & DEERING AVE., CANOGA PARK	G35







● KEY WELLS APPROXIMATE LOCATION

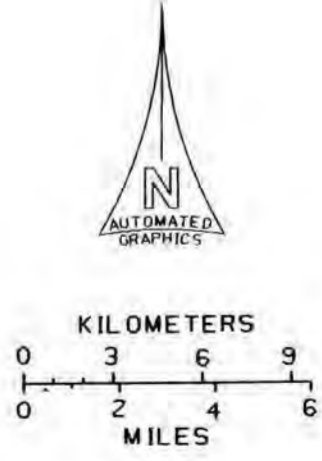

MAP OF  
**COUNTY OF LOS ANGELES**  
 DEPARTMENT OF PUBLIC WORKS  
 KEYWELL LOCATIONS

# GROUNDWATER FLUCTUATIONS FOR WELL NOS. 1346D, 760C & 1366C COASTAL PLAIN

G21

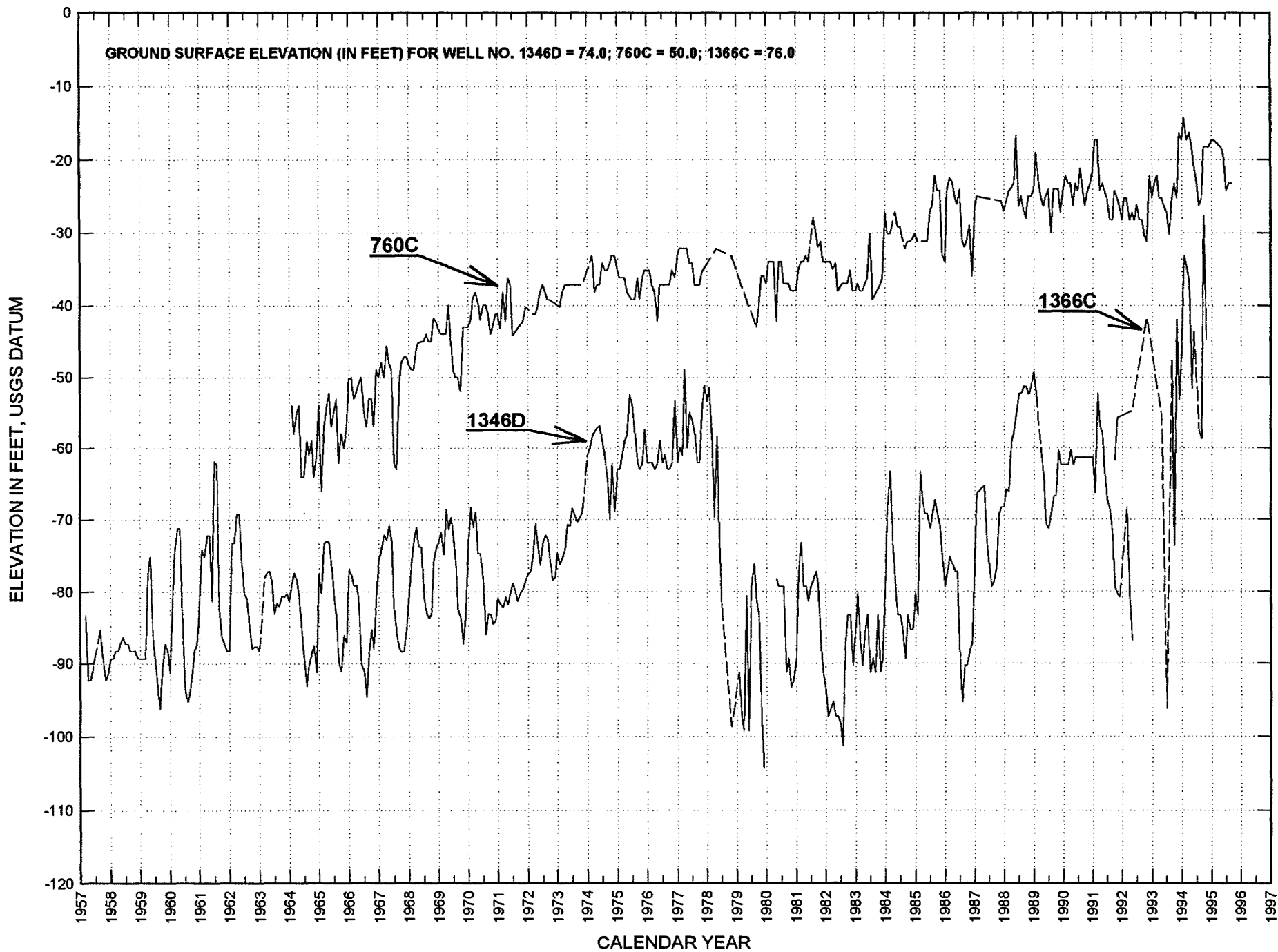



ELEVATION IN FEET, USGS DATUM

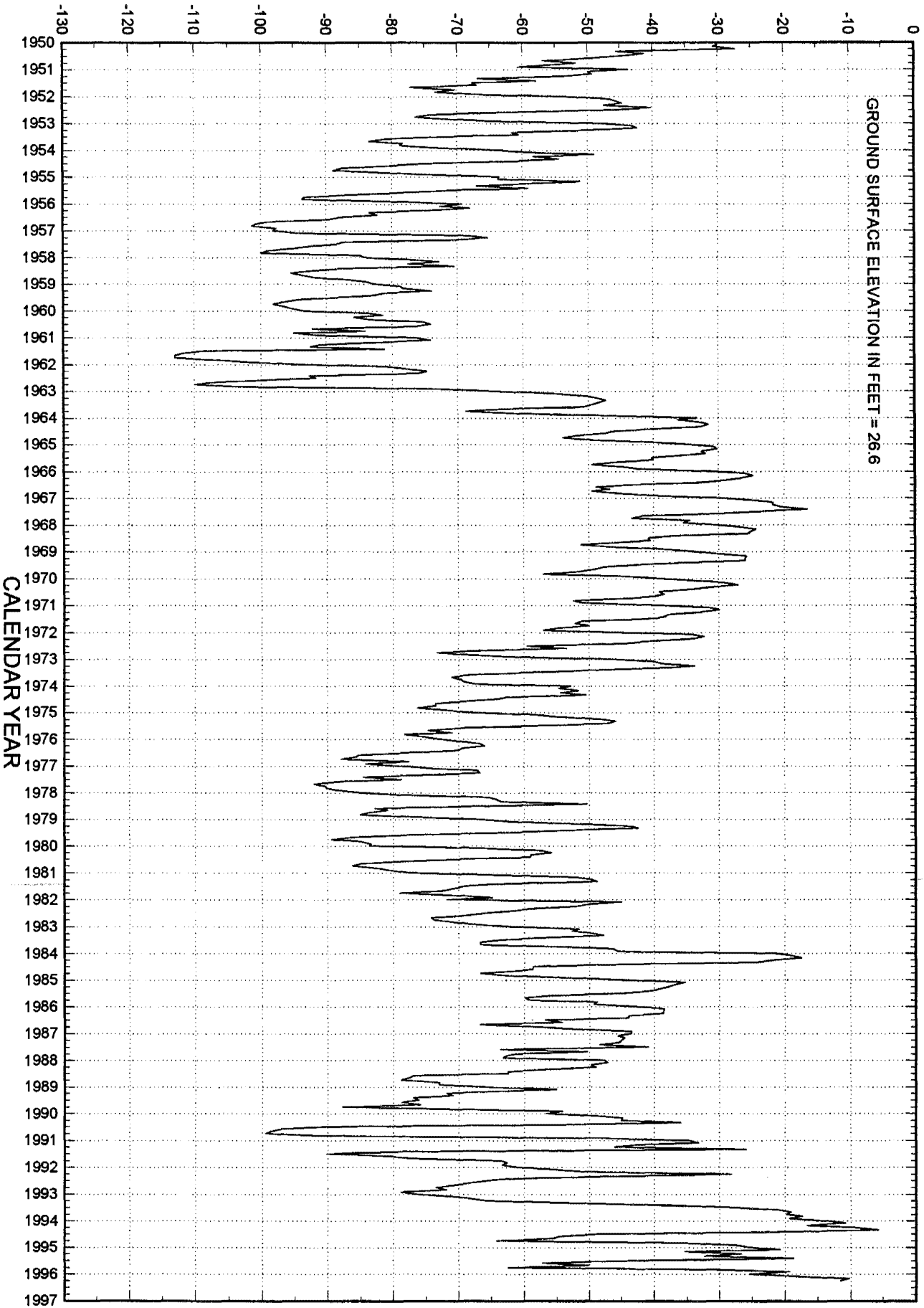

# GROUNDWATER FLUCTUATIONS FOR WELL NO. 460K

CITY OF LONG BEACH, COASTAL PLAIN FORMER ARTESIAN AREA

# GROUNDWATER FLUCTUATIONS FOR WELL NO. 1601T CENTRAL BASIN

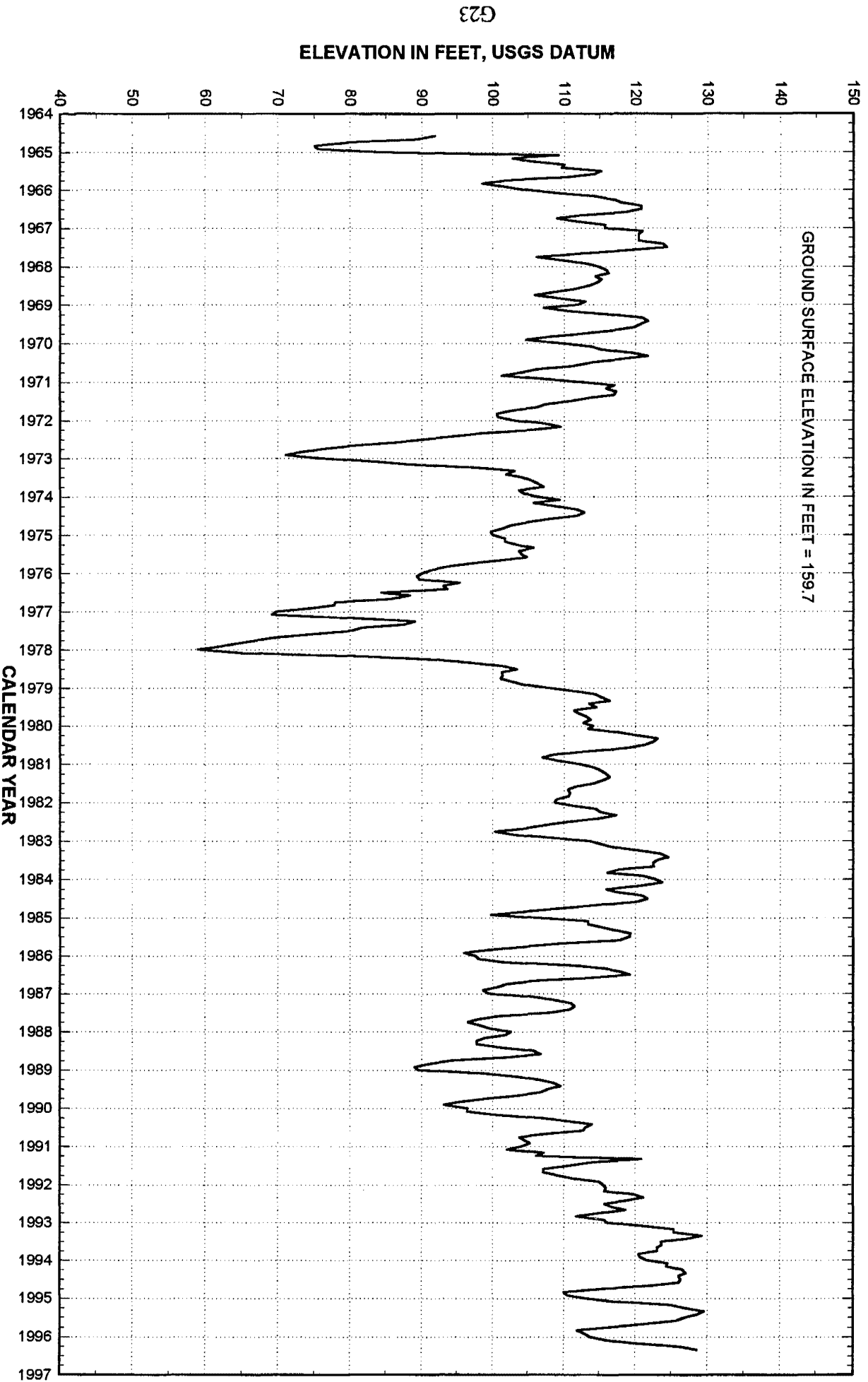

# GROUNDWATER FLUCTUATIONS FOR WELL NO. 906D CITY OF LONG BEACH, COASTAL PLAIN, FORMER ARTESIAN AREA

G24

ELEVATION IN FEET, USGS DATUM

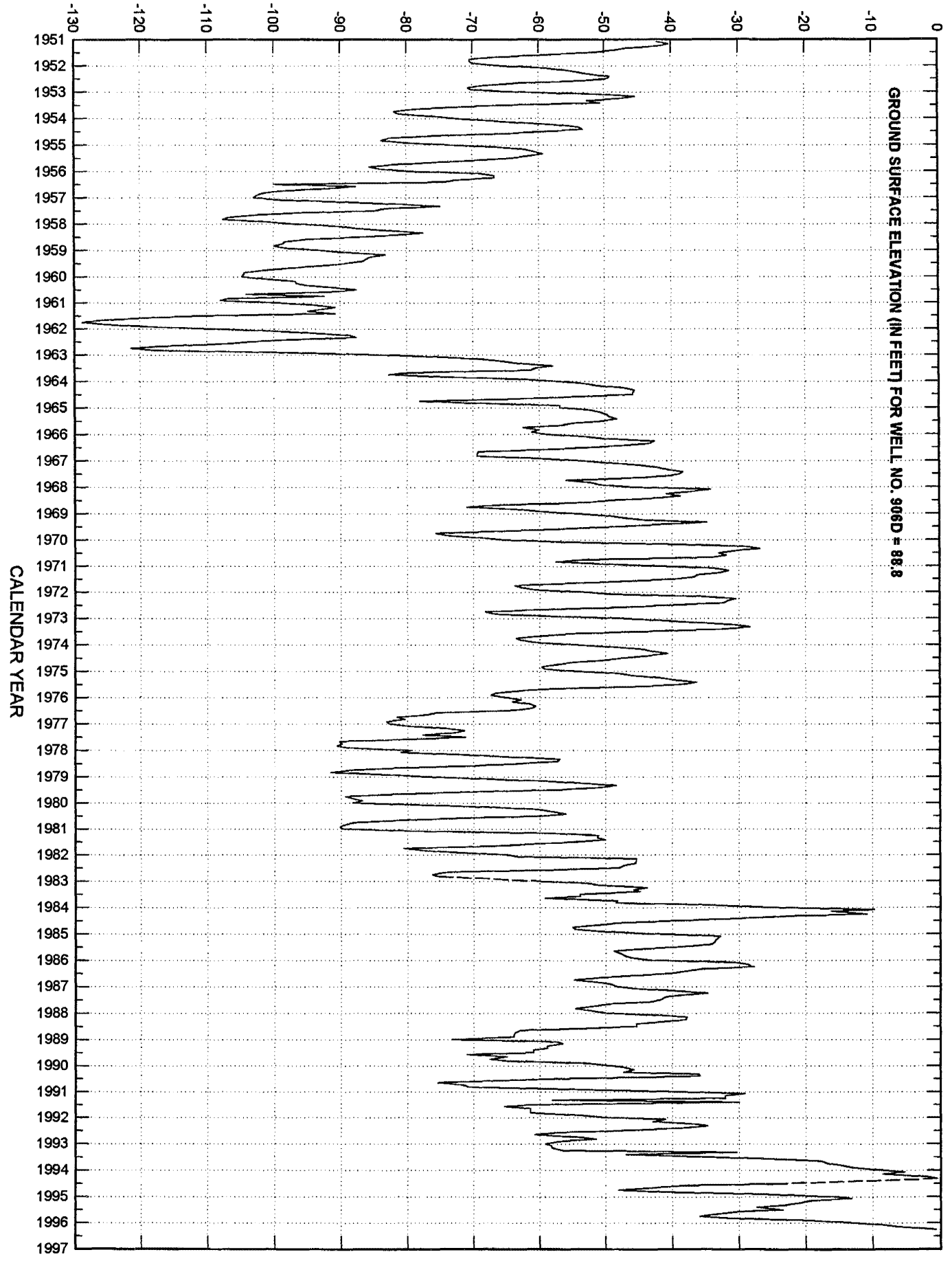

# GROUNDWATER FLUCTUATIONS FOR WELL NO. 3030F

BALDWIN PARK, MAIN SAN GABRIEL BASIN

G25

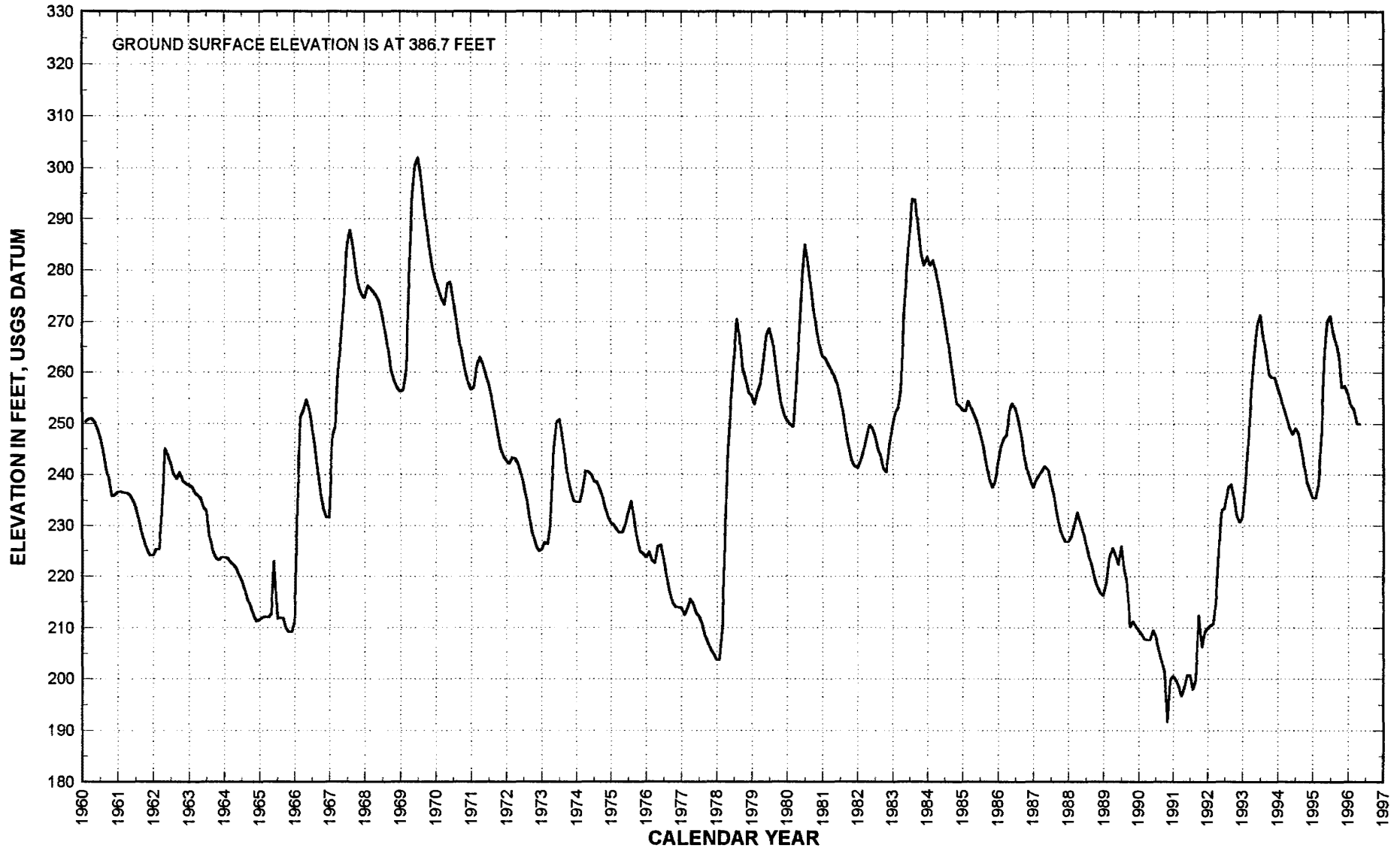

ELEVATION IN FEET, USGS DATUM

# GROUNDWATER FLUCTUATIONS FOR WELL NOS. 2955X & 2965C MAIN SAN GABRIEL BASIN

GROUND SURFACE ELEVATION (IN FEET) FOR WELL NO. 2955X = 231.9; 2965C = 245.0

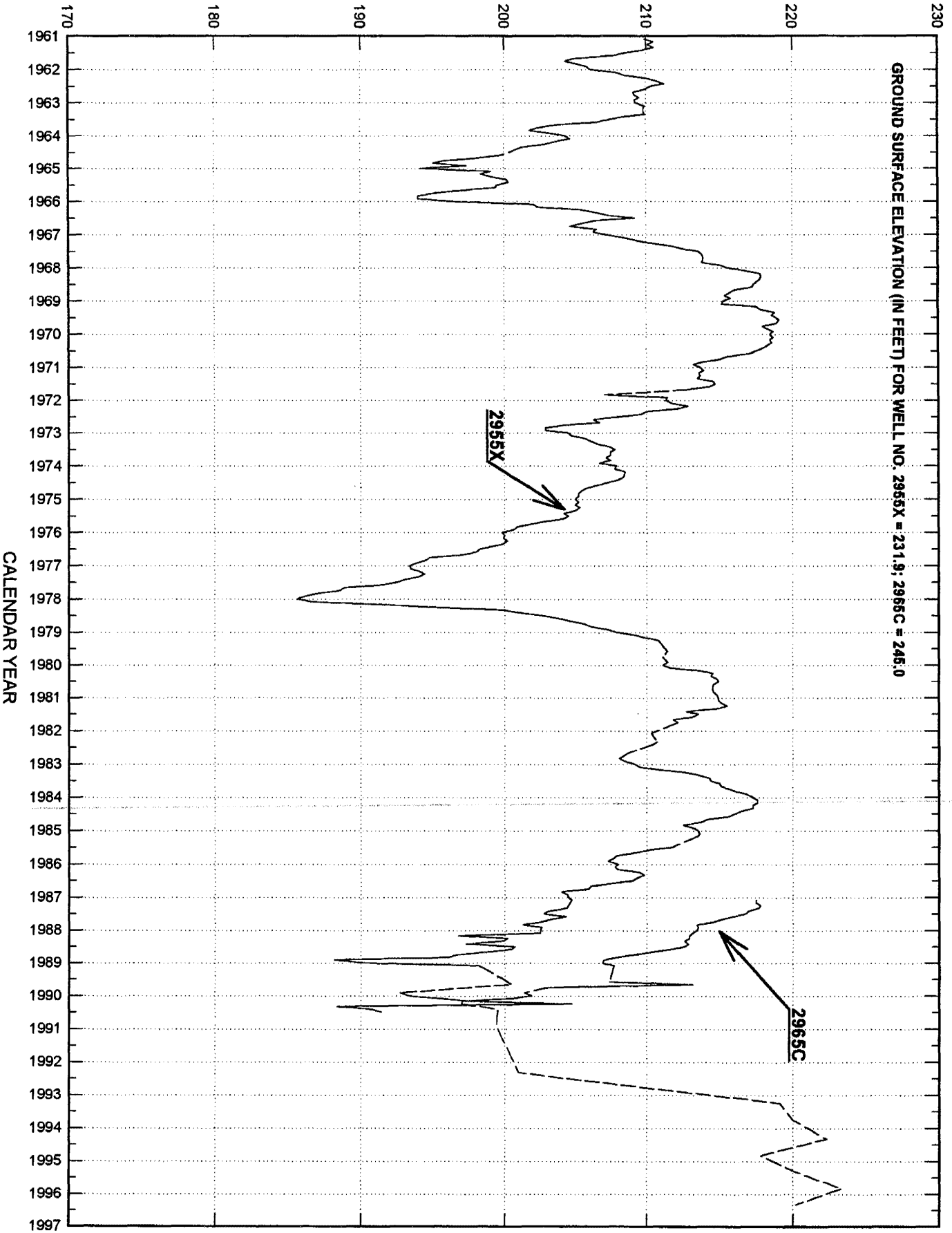

# GROUNDWATER FLUCTUATIONS FOR WELL NOS. 4285 & 4284A

NORTH OF AZUSA; SAN GABRIEL CANYON BASIN

G27

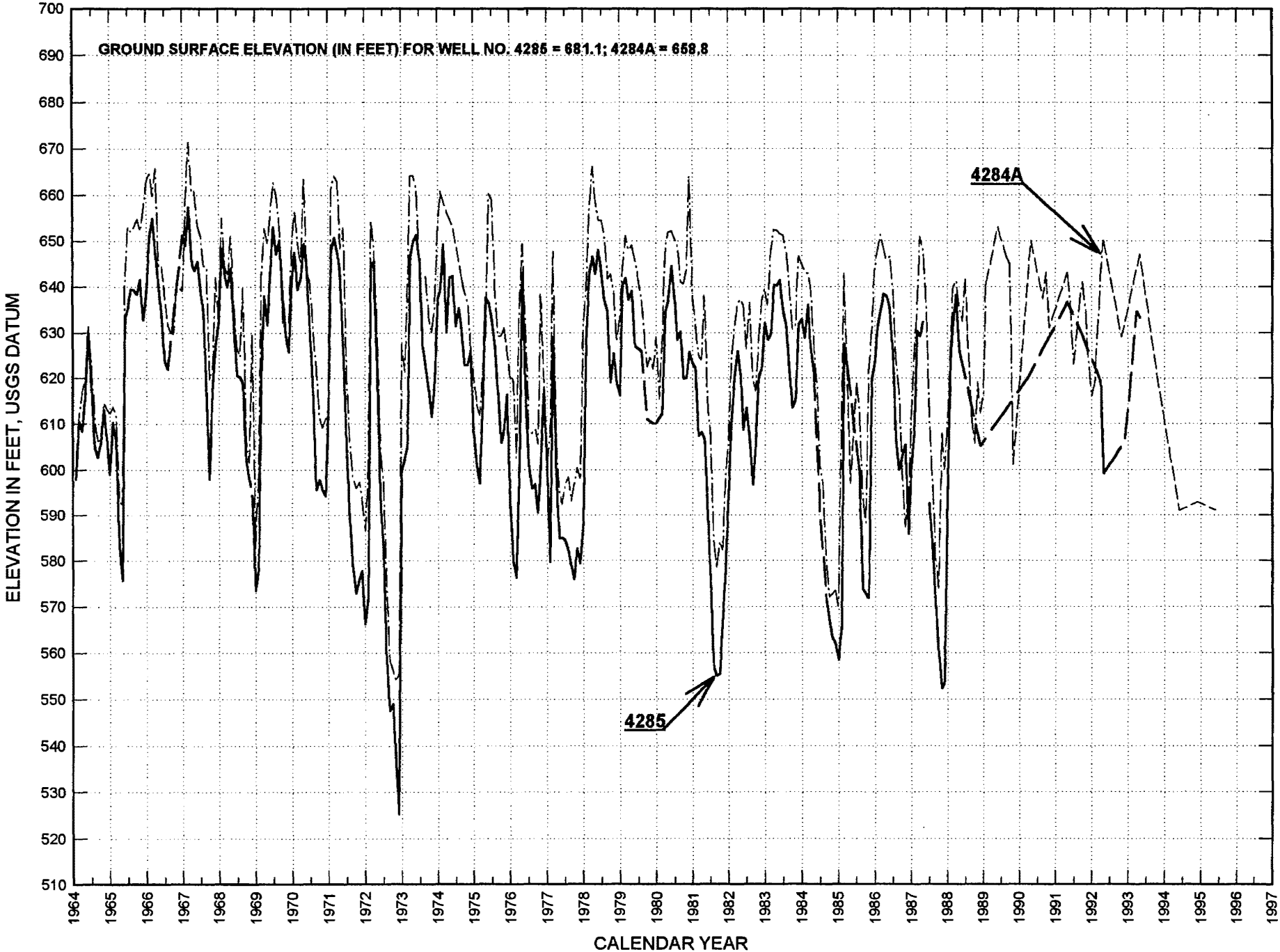



# GROUNDWATER FLUCTUATIONS FOR WELL NOS. 3251E, 3261P & 4469A POMONA BASIN

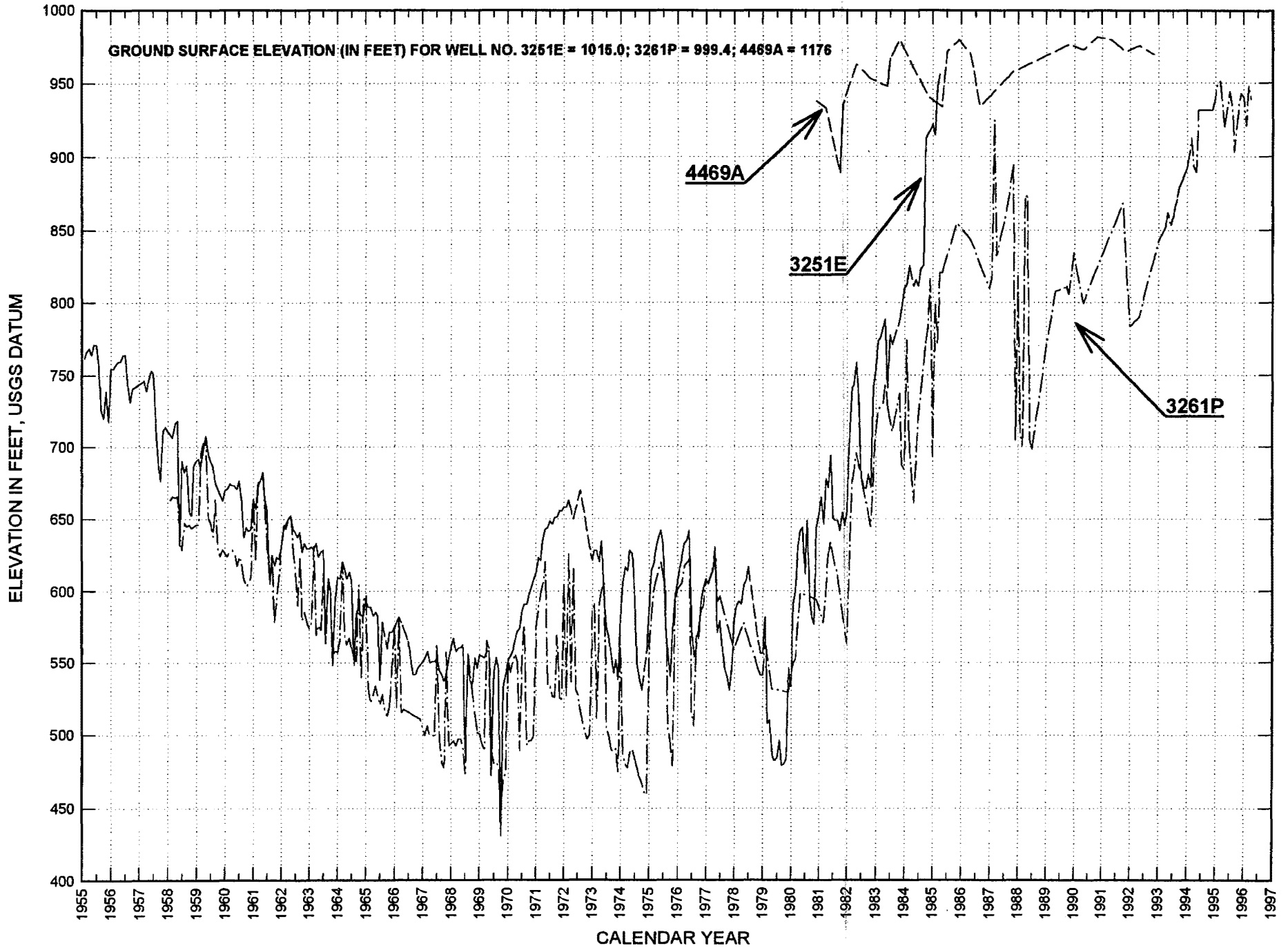

# GROUNDWATER FLUCTUATIONS FOR WELL NOS. 4508A & 4508B

## UPPER CLAREMONT HEIGHTS

G29

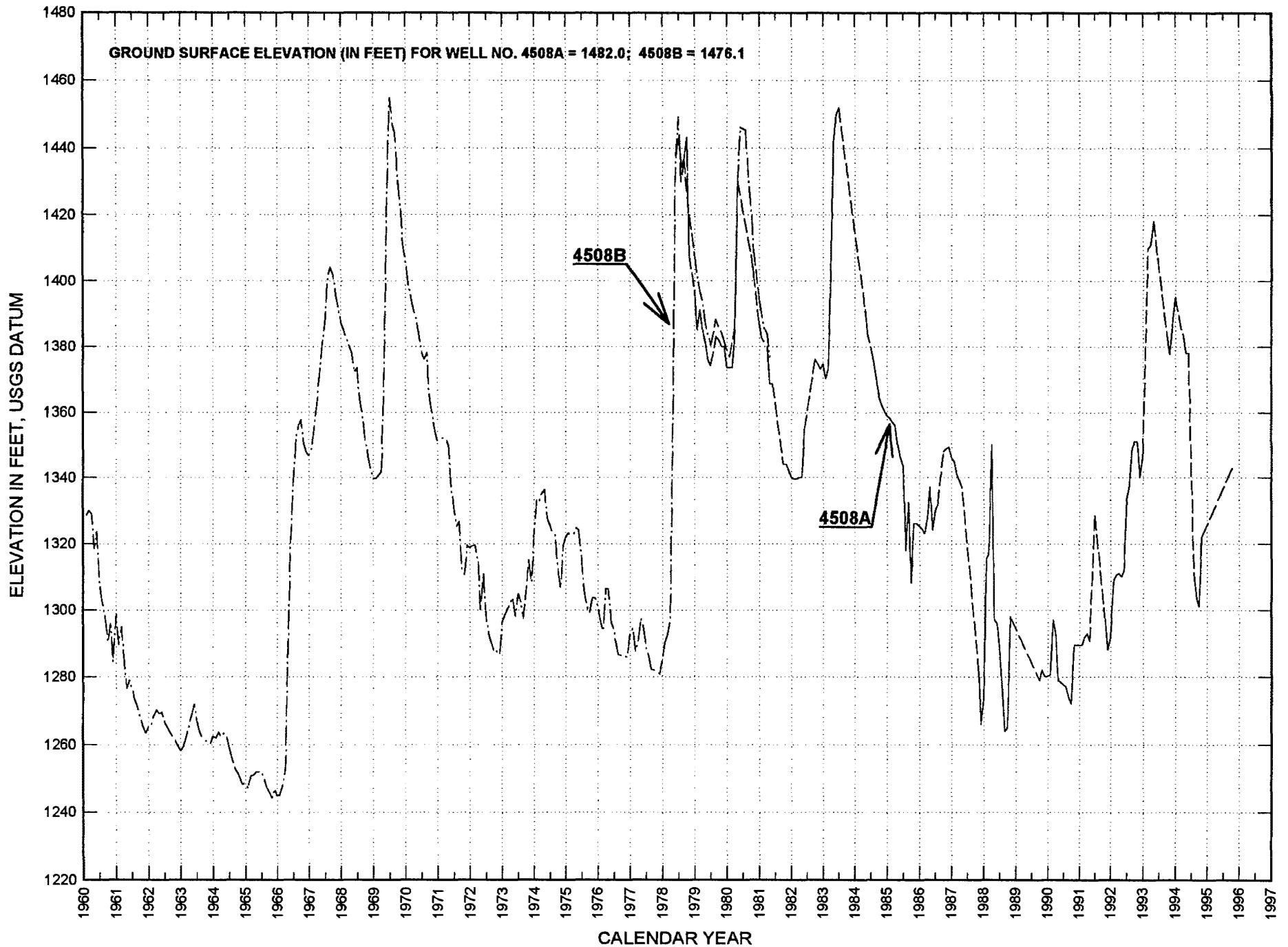

ELEVATION IN FEET, USGS DATUM

# GROUNDWATER FLUCTUATIONS FOR WELL NO. 4057H RAYMOND BASIN

GROUND SURFACE ELEVATION (IN FEET) FOR WELL NO. 4057H = 749.9

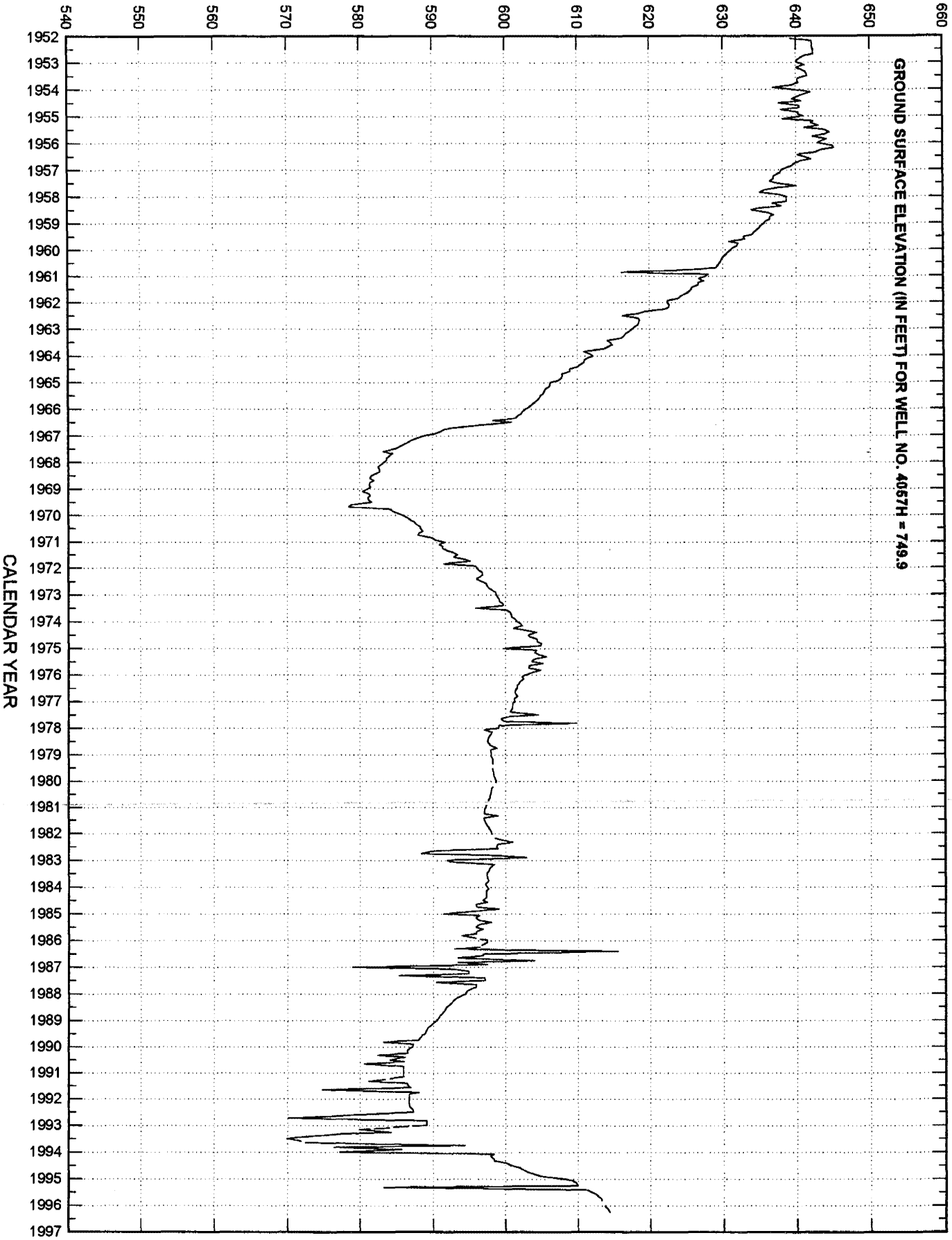

# GROUNDWATER FLUCTUATIONS FOR WELL NOS. 7048A, 7048C & 7057P NEAR CASTAIC JUNCTION, SANTA CLARITA VALLEY

631

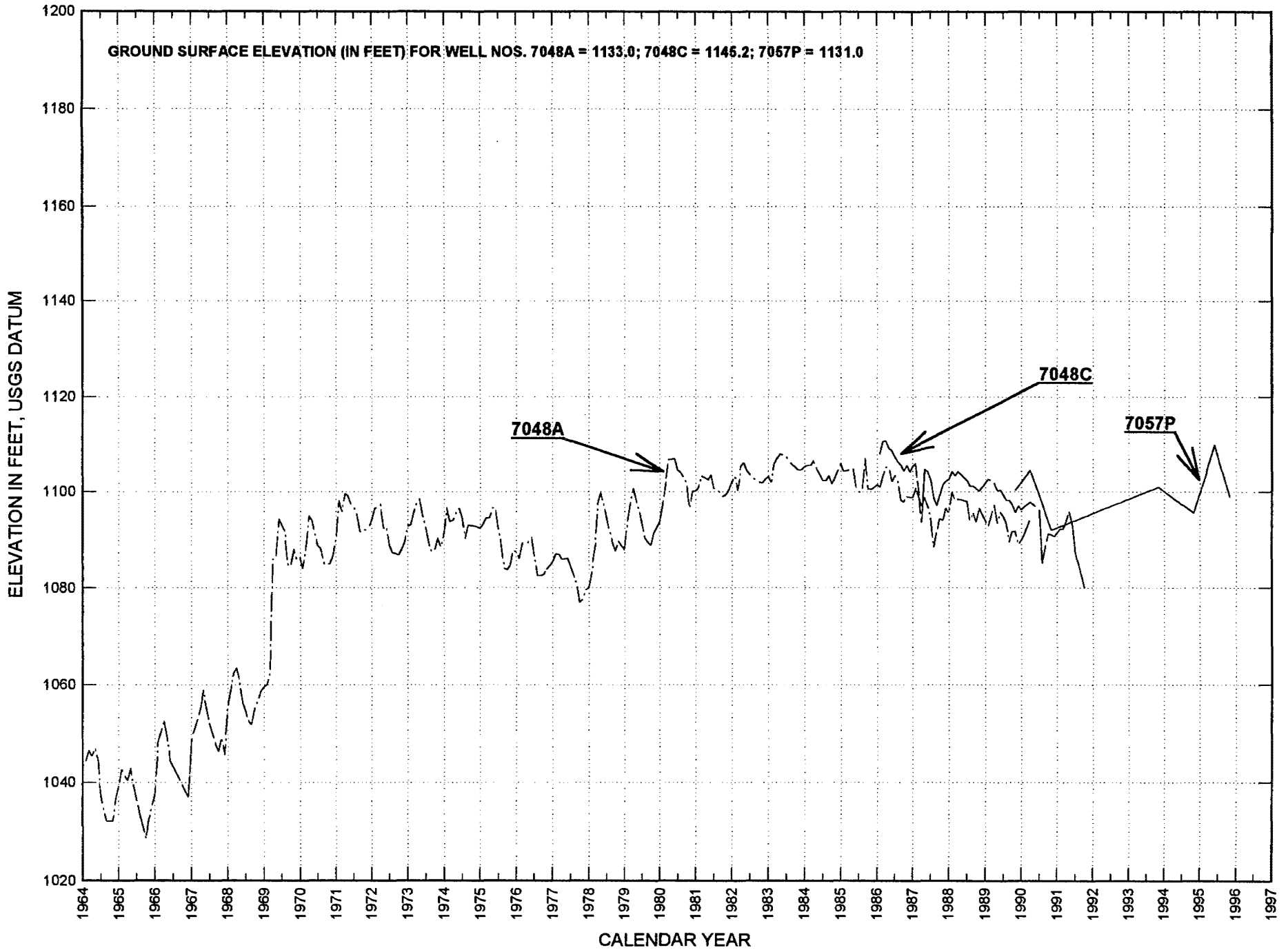

# GROUNDWATER FLUCTUATIONS FOR WELL NOS. 9962B, 9962C, 9962D & 9974 SOUTH OF LANCASTER, ANTELOPE VALLEY

G32

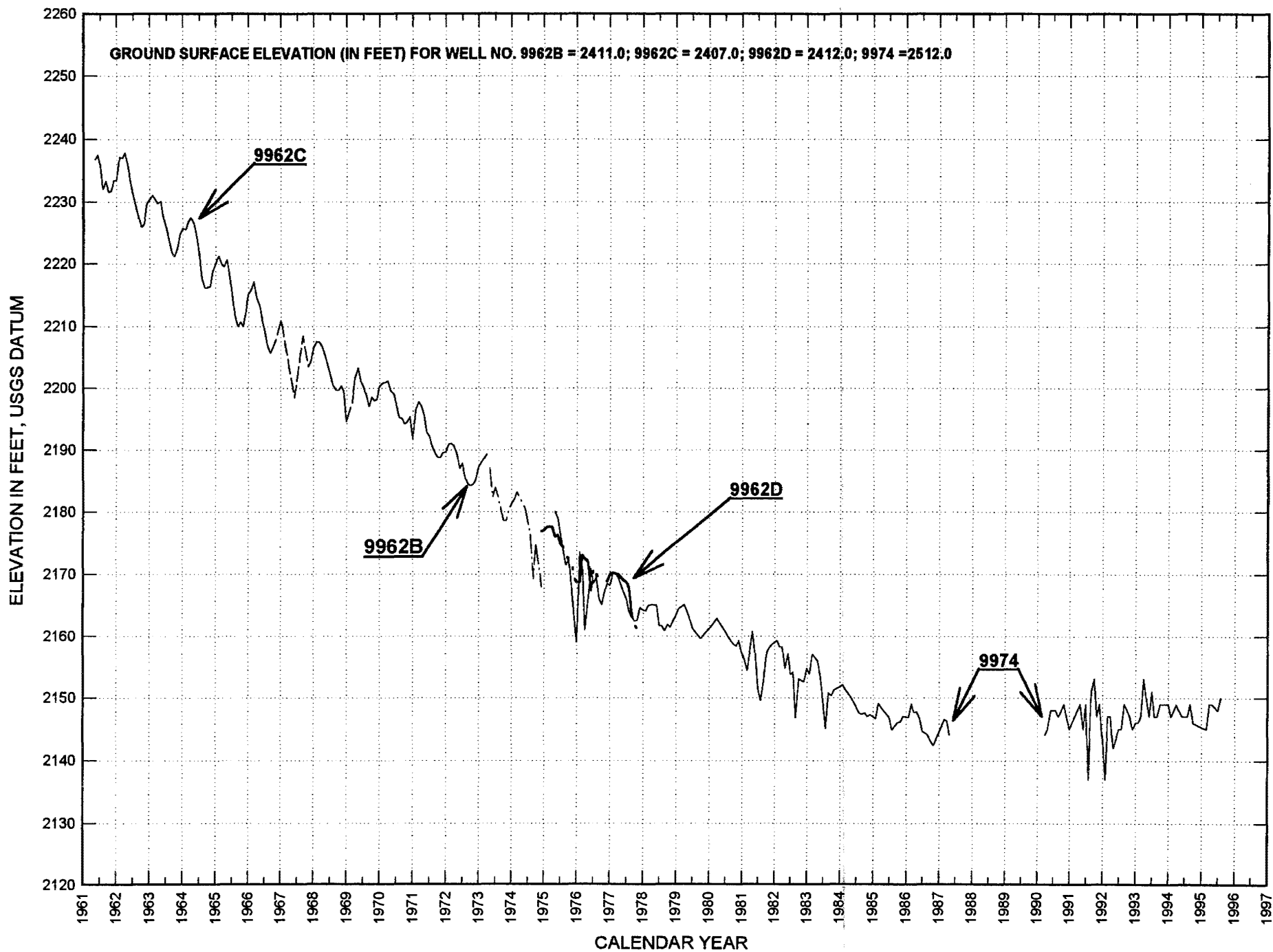

# GROUNDWATER FLUCTUATIONS FOR WELL NO. 8825

SOUTH OF PALMDALE, LITTLE ROCK

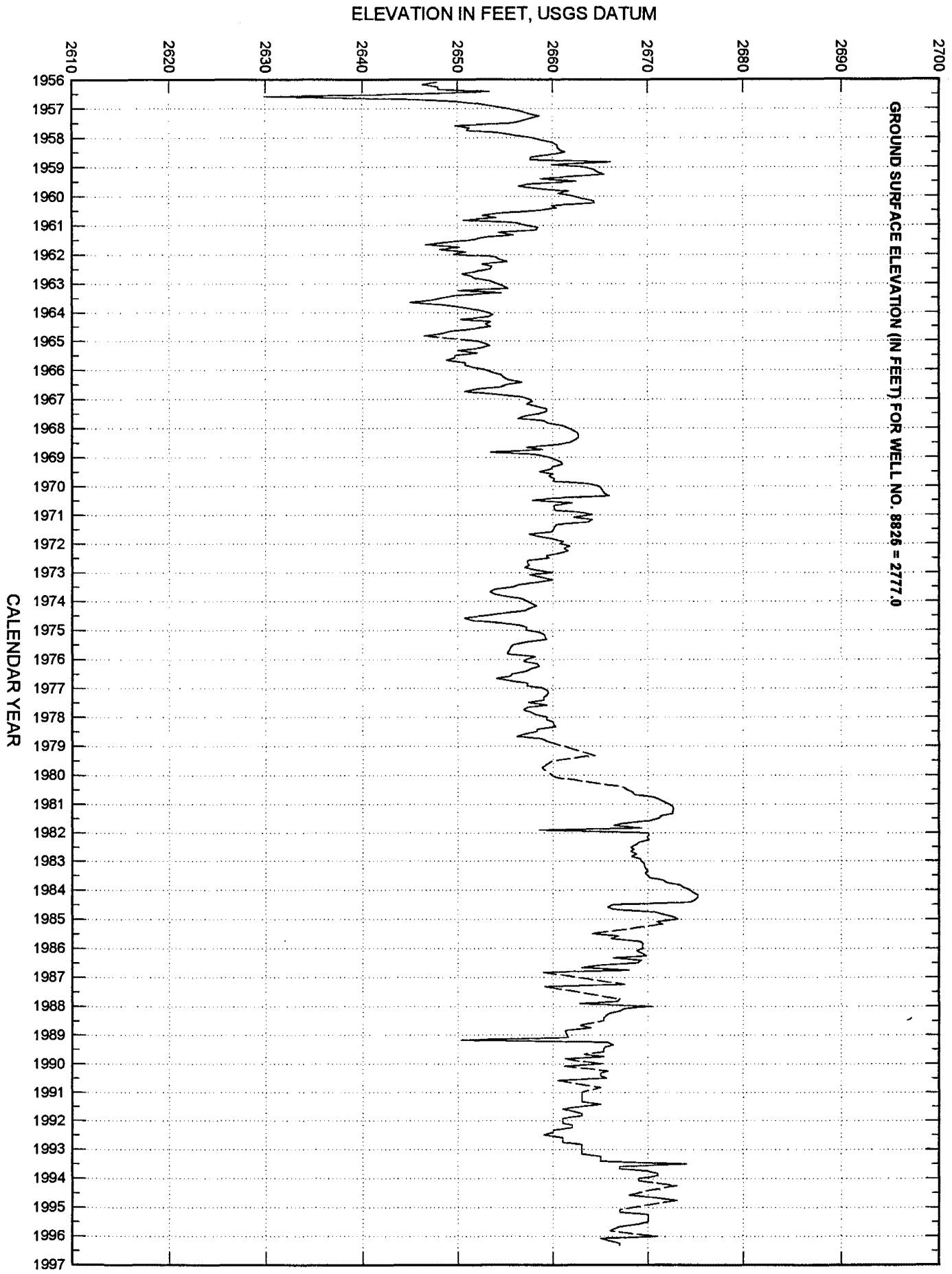



# GROUNDWATER FLUCTUATIONS FOR WELL NO. 3872H

BURBANK, SAN FERNANDO VALLEY

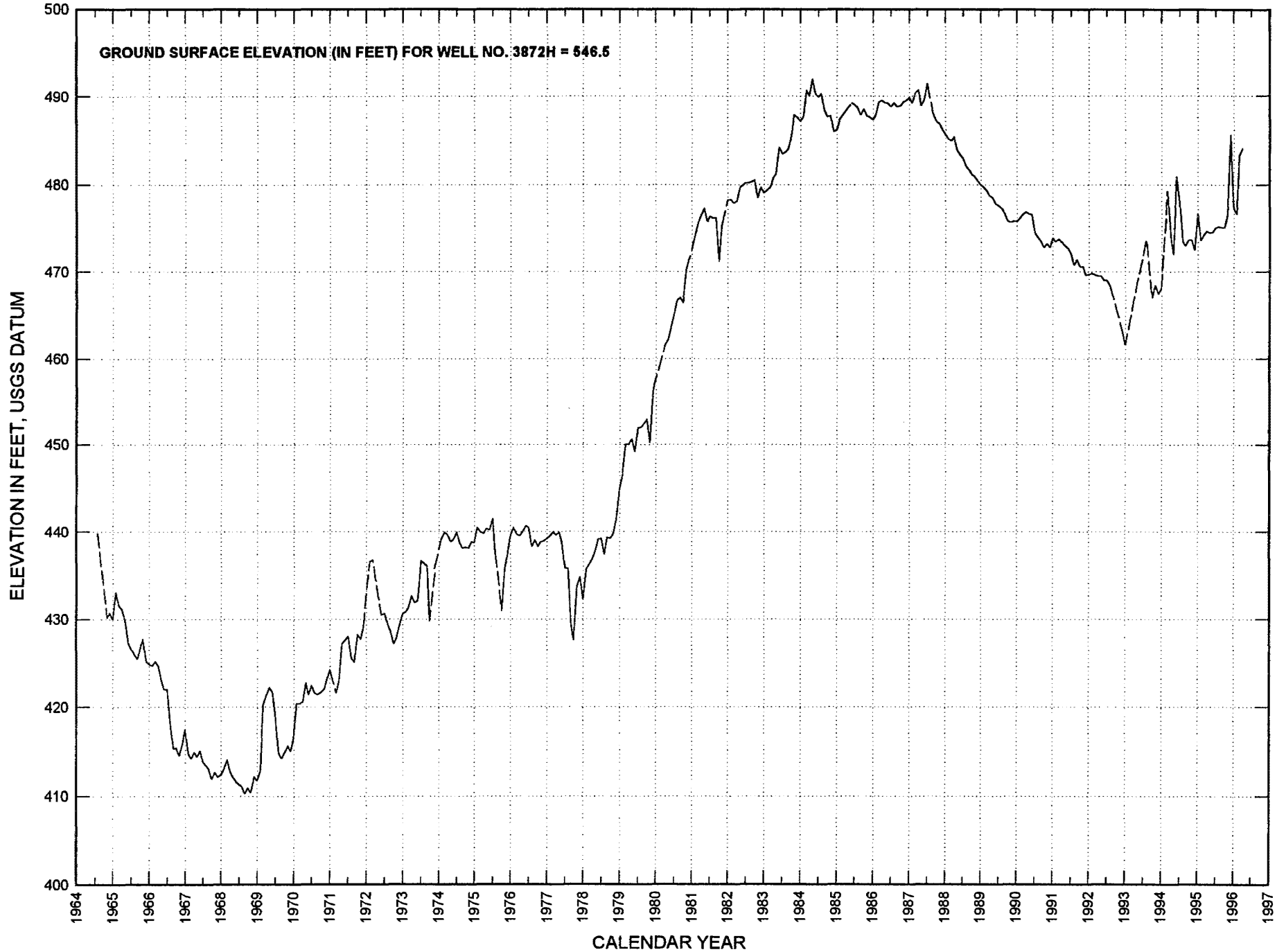

G34

# GROUNDWATER FLUCTUATIONS FOR WELL NOS. 4709 & 3600H

CANOGA PARK, SAN FERNANDO VALLEY

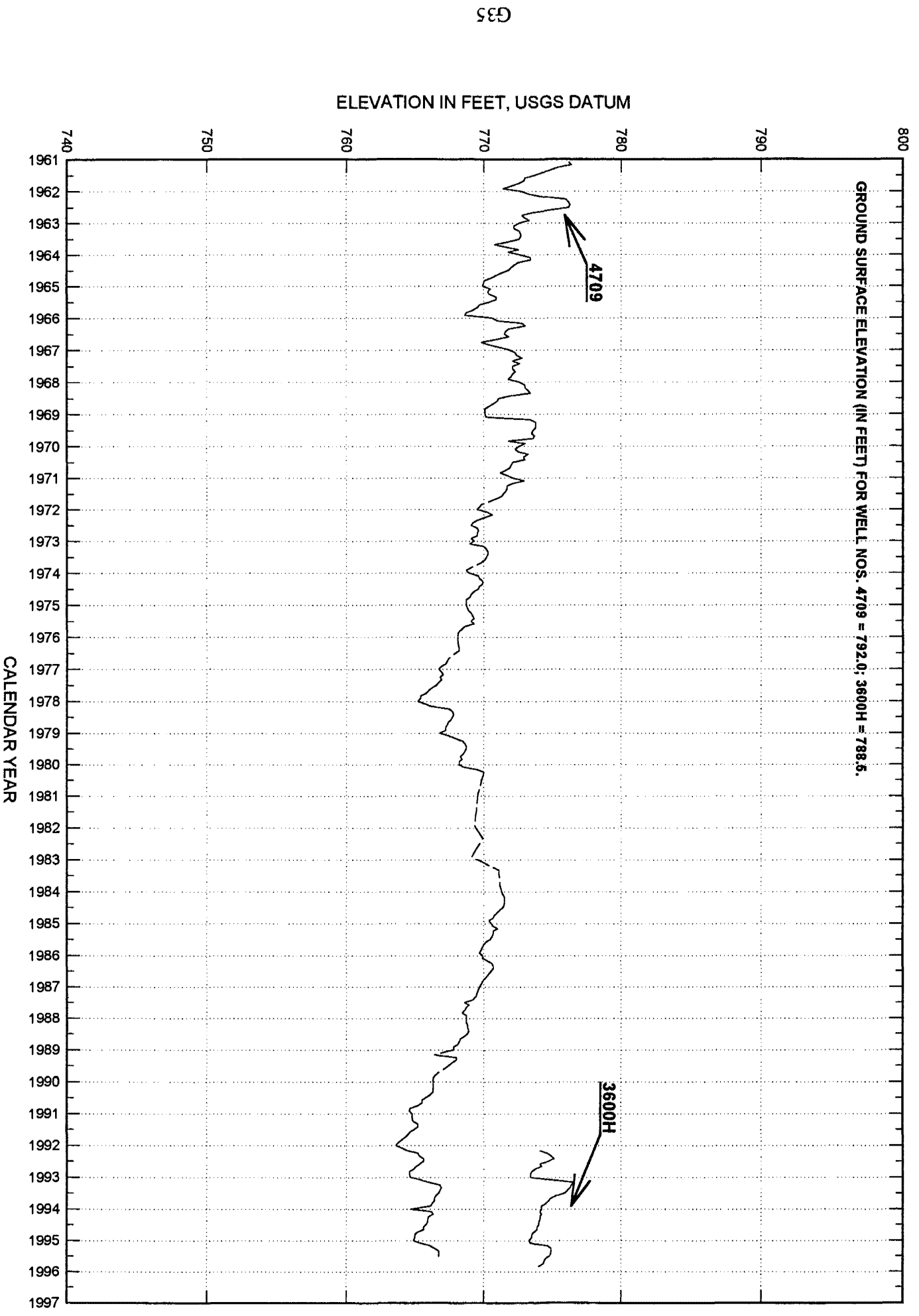





# LOS ANGELES COUNTY DEPARTMENT OF PUBLIC WORKS GROUNDWATER BASINS AND RECHARGE FACILITIES

- 1 CENTRAL BASIN**
  - A** DOMINGUEZ GAP S.G.
  - B** RIO HONDO COASTAL BASIN S.G.
  - C** SAN GABRIEL COASTAL BASIN S.G.
  - D** SAN GABRIEL RIVER (LOWER)
- 2 CHINO BASIN**
- 3 CLAREMONT HEIGHTS BASIN**
  - E** POMONA S.G.  
(this facility of owned and operated by the Pomona Valley Protective Assn.)
  - F** SAN ANTONIO S.G.  
(this facility of owned and operated by the Pomona Valley Protective Assn.)
  - G** THOMPSON CK. S.G.  
(this facility of owned and operated by the Pomona Valley Protective Assn.)
- 4 EAGLE ROCK BASIN**
- 5 FOOTHILL BASIN**
  - H** SAN DIMAS CYN. S.G.

- 6 GLENDORA BASIN**
  - I** BIG DALTON S.G.
  - J** LITTLE DALTON S.G.
- 7 HOLLYWOOD BASIN**
- 8 LA HABRA BASIN**
- 9 LIVE OAK BASIN**
- 10 LOWER SAN GABRIEL CANYON BASIN**
  - K** SAWPIT S.G.
- 11 MAIN SAN GABRIEL BASIN**
  - L** BEN LOMOND S.G.
  - M** BUENA VISTA S.B.
  - N** CITRUS S.G.
  - O** EATON S.B.
  - P** IRWINDALE S.B./MANNING PIT
  - Q** PECK RD. S.B.
  - R** SAN GABRIEL RIVER (UPPER)
  - S** SANTA FE RESERVOIR S.G.
  - T** WALNUT S.B.
  - U** WHITTIER NARROWS W.C. DIVERSION CANAL (ZONE 1 DITCH)

- 12 POMONA BASIN**
- 13 PUENTE BASIN**
- 14 RAYMOND BASIN**
  - V** ARROYO SECO S.G.
  - W** EATON S.G.
  - X** SANTA ANITA S.G.
  - Y** SIERRA MADRE S.G.
- 15 SAN DIMAS BASIN**
  - Z** LIVE OAK S.G.
- 16 SAN FERNANDO BASIN**
  - AA** BRANFORD S.B.
  - BB** HANSEN S.G.
  - CC** HEADWORKS S.G.  
(this facility is owned and operated by the City of Los Angeles - D.W.P.)
  - DD** LOPEZ S.G.
  - EE** PACOIMA S.G.  
(owned by the City of Los Angeles - D.W.P.)  
(operated by the County of Los Angeles - L.A.C.D.P.W.)
  - FF** TUJUNGA S.G.  
(owned by the City of Los Angeles - D.W.P.)  
(operated by the County of Los Angeles - L.A.C.D.P.W.)

- 17 SANTA MONICA BASIN**
- 18 SPADRA BASIN**
- 19 SYLMAR BASIN**
- 20 UPPER SAN GABRIEL CANYON BASIN**
  - GG** FISH CYN. S.G.  
(this facility is owned and operated by Cal American Water Co.)
  - HH** SAN GABRIEL CANYON S.G.
- 21 VERDUGO BASIN**
- 22 WAY HILL BASIN**
- 23 WEST COAST BASIN**

- - SGVMWD
- - OWENS VALLEY (LA)
- - MWD OUTLETS

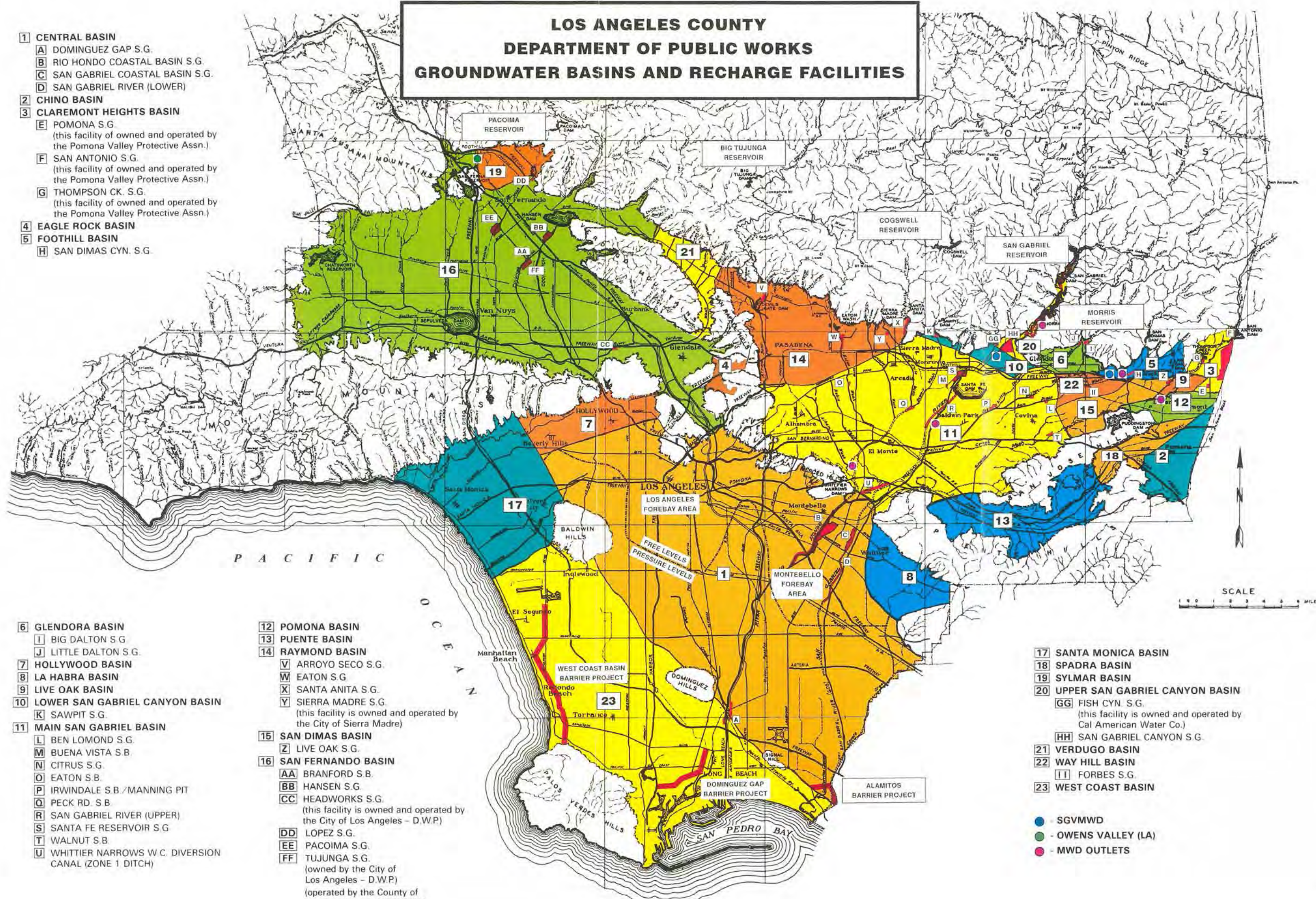



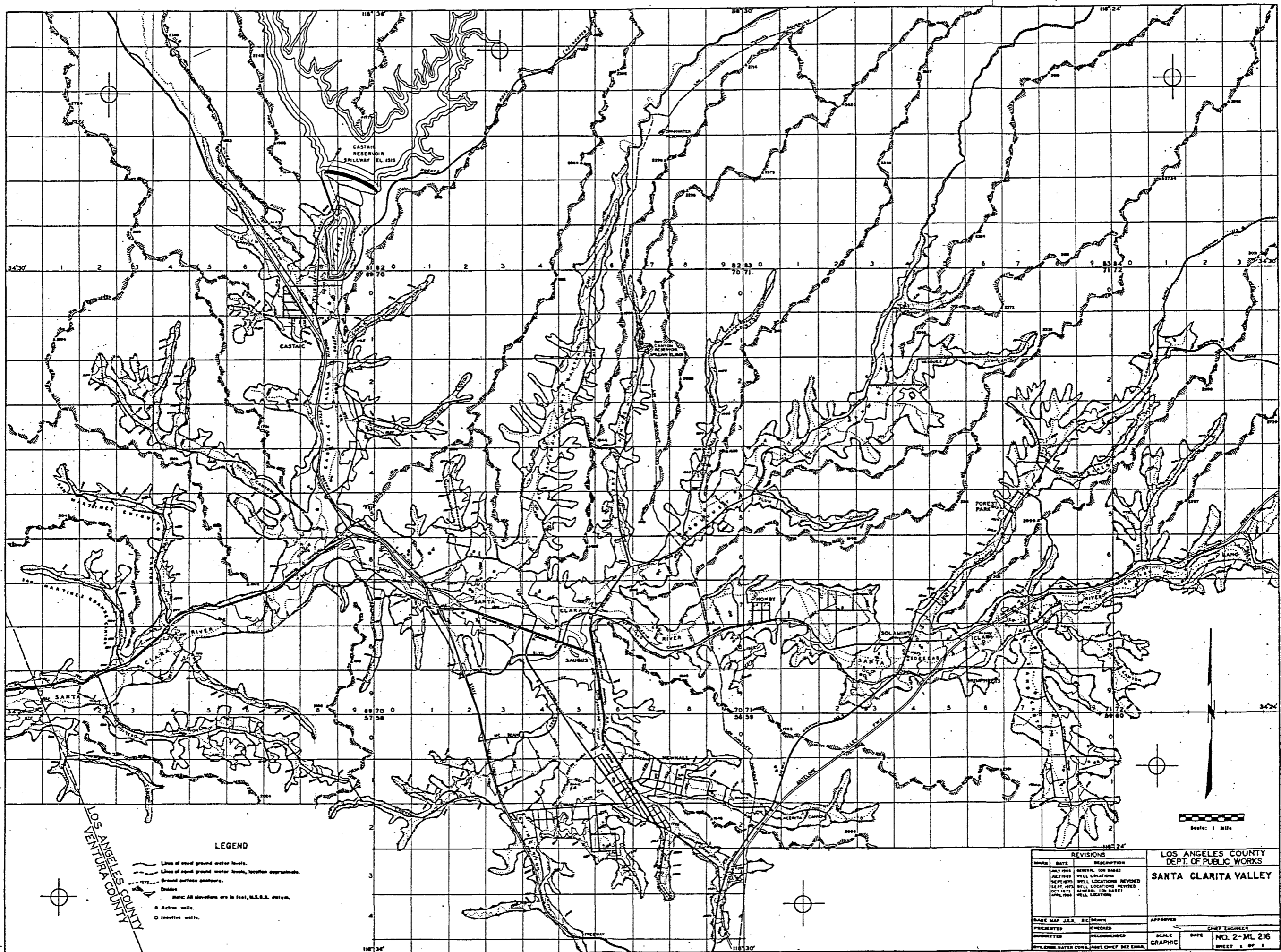

LOS ANGELES COUNTY  
VENTURA COUNTY

**LEGEND**

- Lines of equal ground water levels.
  - - - Lines of equal ground water levels, location approximate.
  - Ground surface contours.
  - Wells.
  - Active wells.
  - Inactive wells.
- Note: All elevations are in feet, U.S.S.S. datum.

REVISIONS			LOS ANGELES COUNTY DEPT. OF PUBLIC WORKS	
NO.	DATE	DESCRIPTION	SANTA CLARITA VALLEY	
JULY 1964	GENERAL	(ON BASE)		
AUG 1968	WELL LOCATIONS			
SEPT 1970	WELL LOCATIONS	REVISED		
SEPT 1973	WELL LOCATIONS	REVISED		
OCT 1975	GENERAL	(ON BASE)		
APR 1986	WELL LOCATIONS			

BASE MAP J.E.A. B.C. 1964	APPROVED	CHIEF ENGINEER
PREPARED BY	CHECKED	
DESIGNED BY	RECOMMENDED	
BY: JOHN BATES CONSULTANTS	ASST. CHIEF ENG. CORRA	
SCALE GRAPHIC	DATE	NO. 2-ML 216
		SHEET 1 OF 1

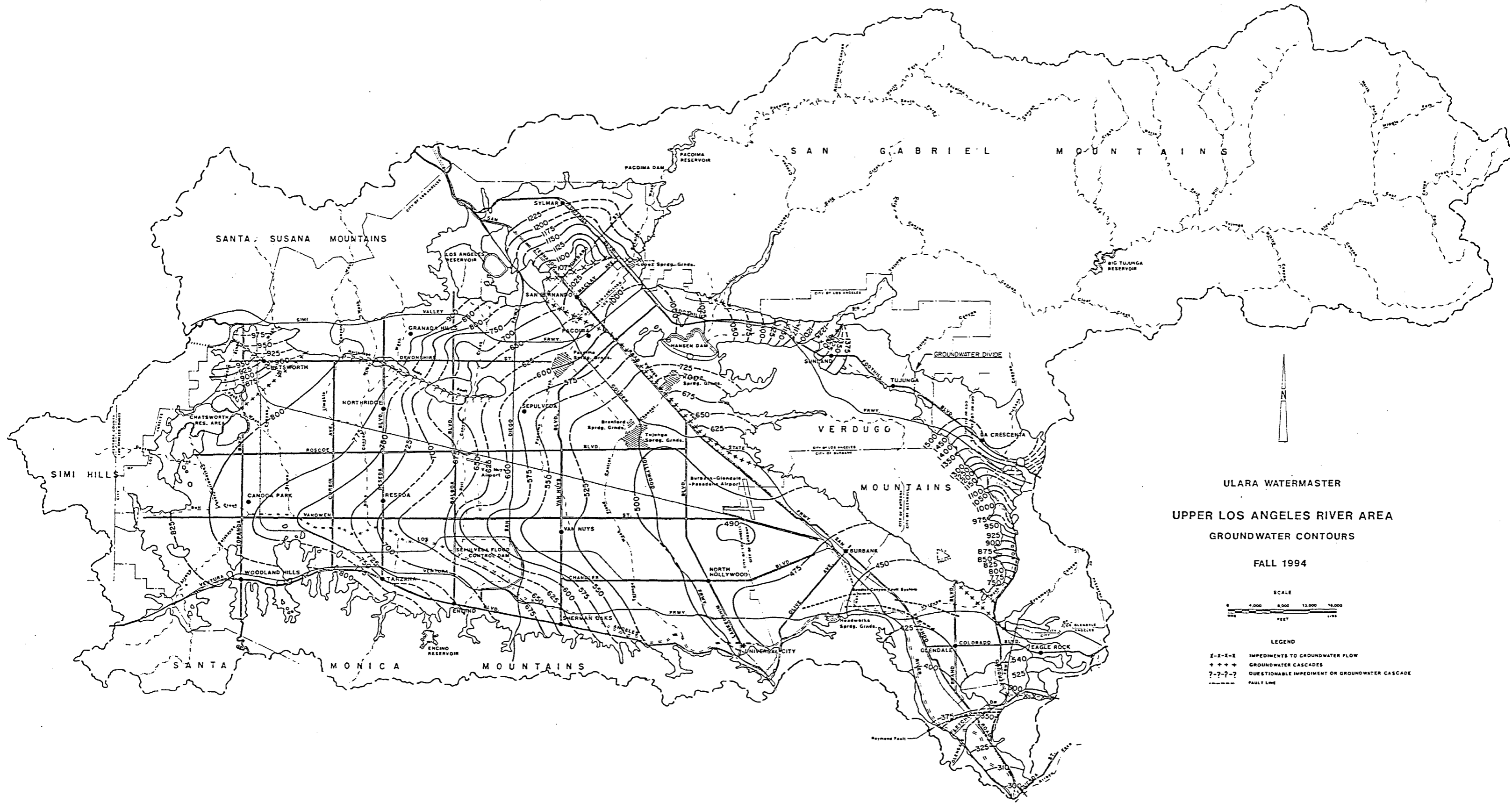

ULARA WATERMASTER  
 UPPER LOS ANGELES RIVER AREA  
 GROUNDWATER CONTOURS  
 FALL 1994

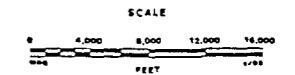

- LEGEND
- - - - - IMPEDIMENTS TO GROUNDWATER FLOW
  - + + + + + GROUNDWATER CASCADES
  - ? - ? - ? - ? QUESTIONABLE IMPEDIMENT OR GROUNDWATER CASCADE
  - FAULT LINE



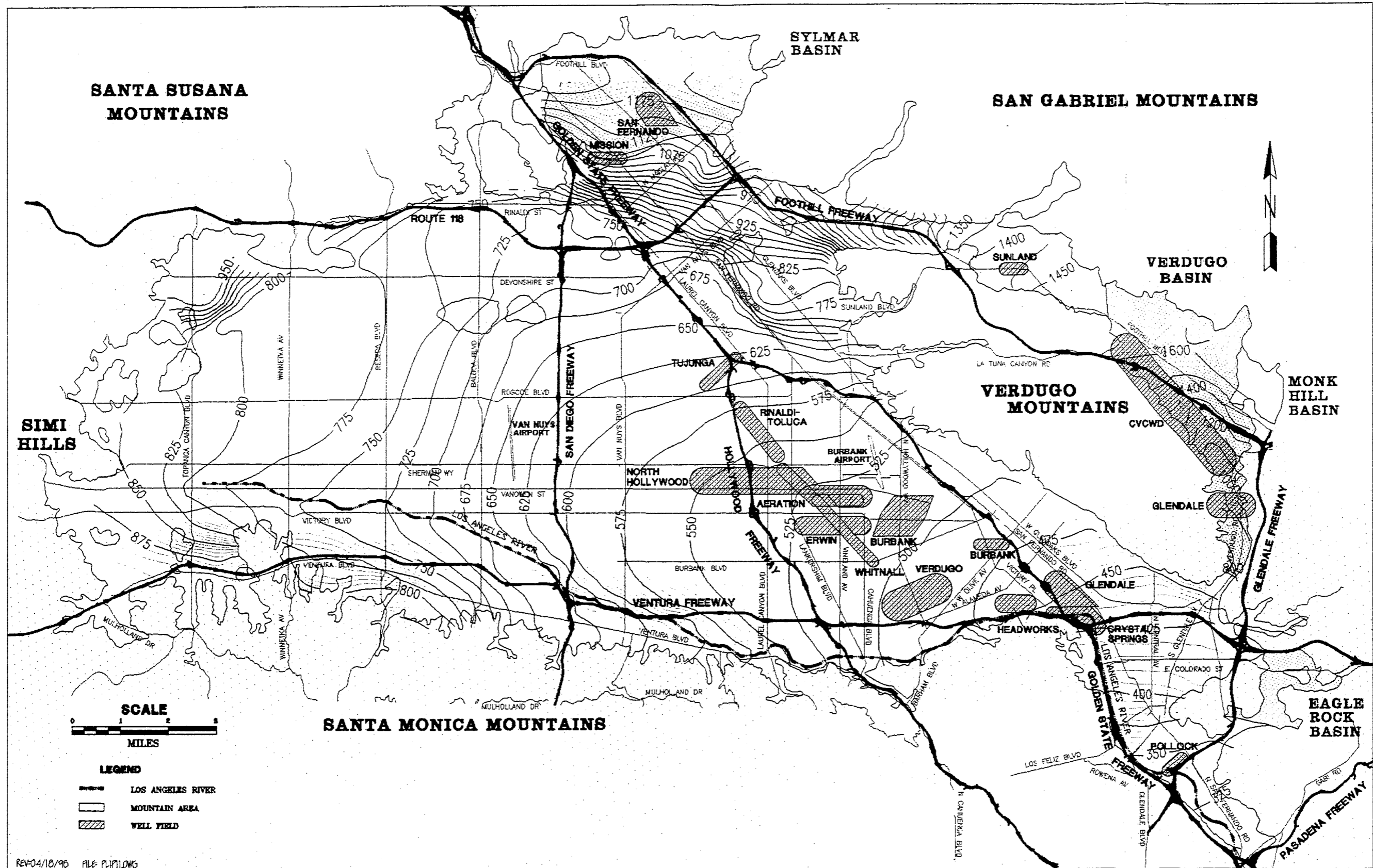

**ULARA Watermaster  
Report**

**Simulated Groundwater Contours  
FALL ( September ) 1995**

**PLATE  
12**

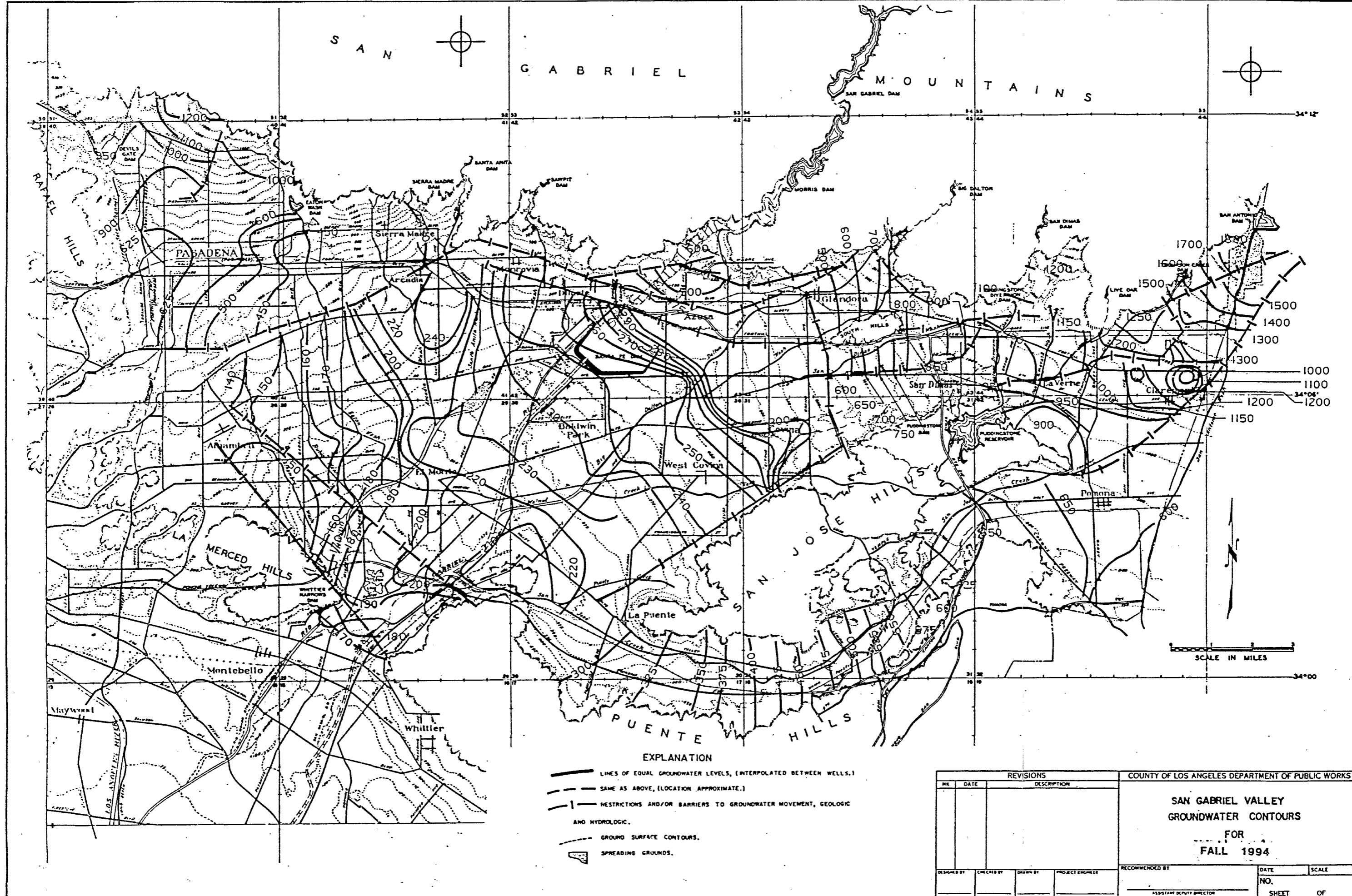

S A N G A B R I E L M O U N T A I N S

- EXPLANATION**
- LINES OF EQUAL GROUNDWATER LEVELS, (INTERPOLATED BETWEEN WELLS.)
  - - - SAME AS ABOVE, (LOCATION APPROXIMATE.)
  - |-| RESTRICTIONS AND/OR BARRIERS TO GROUNDWATER MOVEMENT, GEOLOGIC AND HYDROLOGIC.
  - - - GROUND SURFACE CONTOURS.
  - ◻ SPREADING GROUNDS.

SCALE IN MILES

REVISIONS				COUNTY OF LOS ANGELES DEPARTMENT OF PUBLIC WORKS	
NO.	DATE	DESCRIPTION			
				<b>SAN GABRIEL VALLEY GROUNDWATER CONTOURS</b> FOR <b>FALL 1994</b>	
DESIGNED BY				RECOMMENDED BY	
CHECKED BY				DATE	
DRAWN BY				SCALE	
PROJECT ENGINEER				NO.	
ASSISTANT DEPUTY DIRECTOR				SHEET OF	

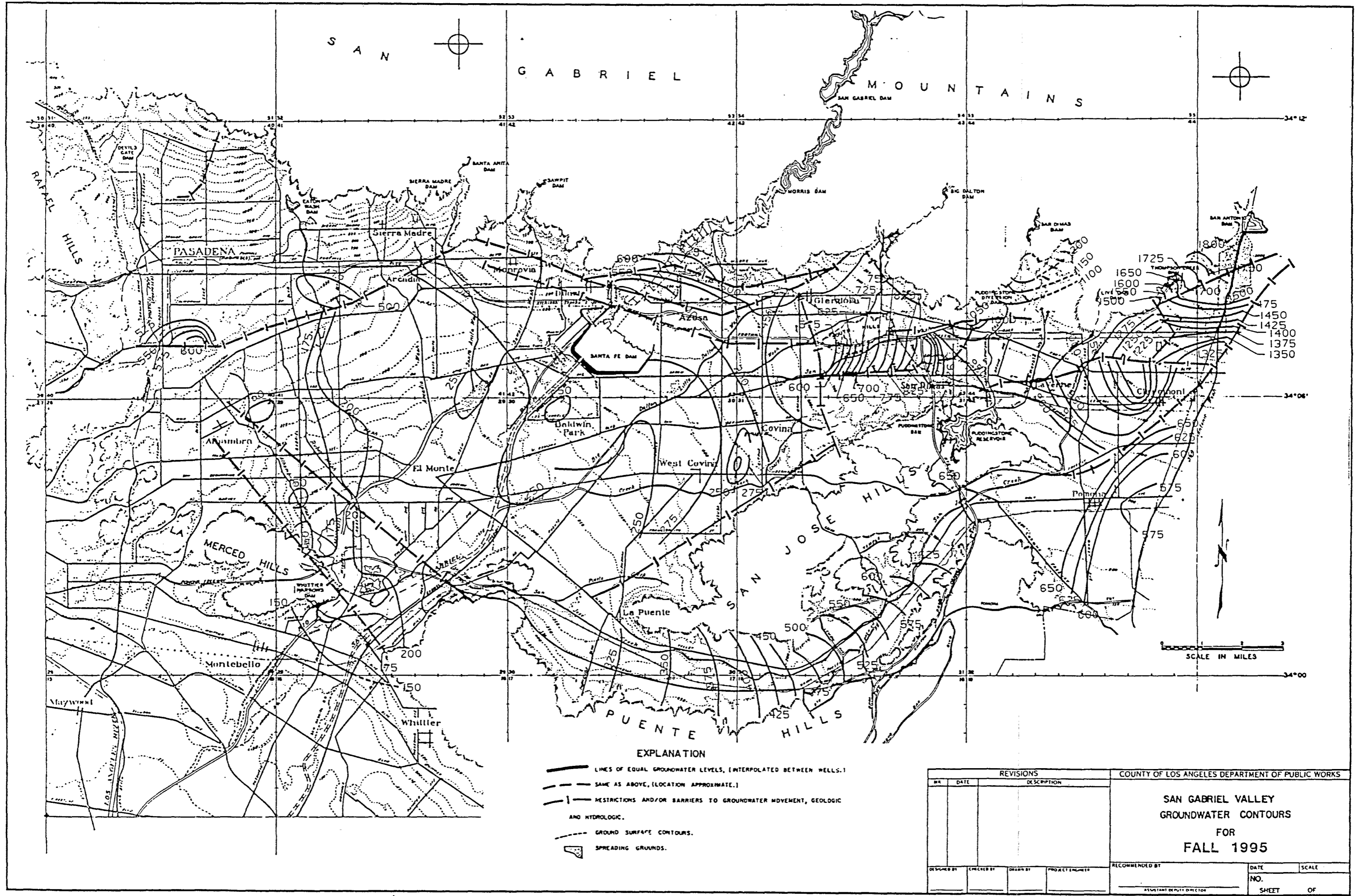

**EXPLANATION**

- LINES OF EQUAL GROUNDWATER LEVELS, (INTERPOLATED BETWEEN WELLS.)
- SAME AS ABOVE, (LOCATION APPROXIMATE.)
- RESTRICTIONS AND/OR BARRIERS TO GROUNDWATER MOVEMENT, GEOLOGIC AND HYDROLOGIC.
- GROUND SURFACE CONTOURS.
- SPREADING GROUNDS.

REVISIONS		
NO.	DATE	DESCRIPTION

COUNTY OF LOS ANGELES DEPARTMENT OF PUBLIC WORKS		
<b>SAN GABRIEL VALLEY GROUNDWATER CONTOURS FOR FALL 1995</b>		
DESIGNED BY	CHECKED BY	DRAWN BY
PROJECT ENGINEER	RECOMMENDED BY	DATE
		SCALE
		NO.
		SHEET OF

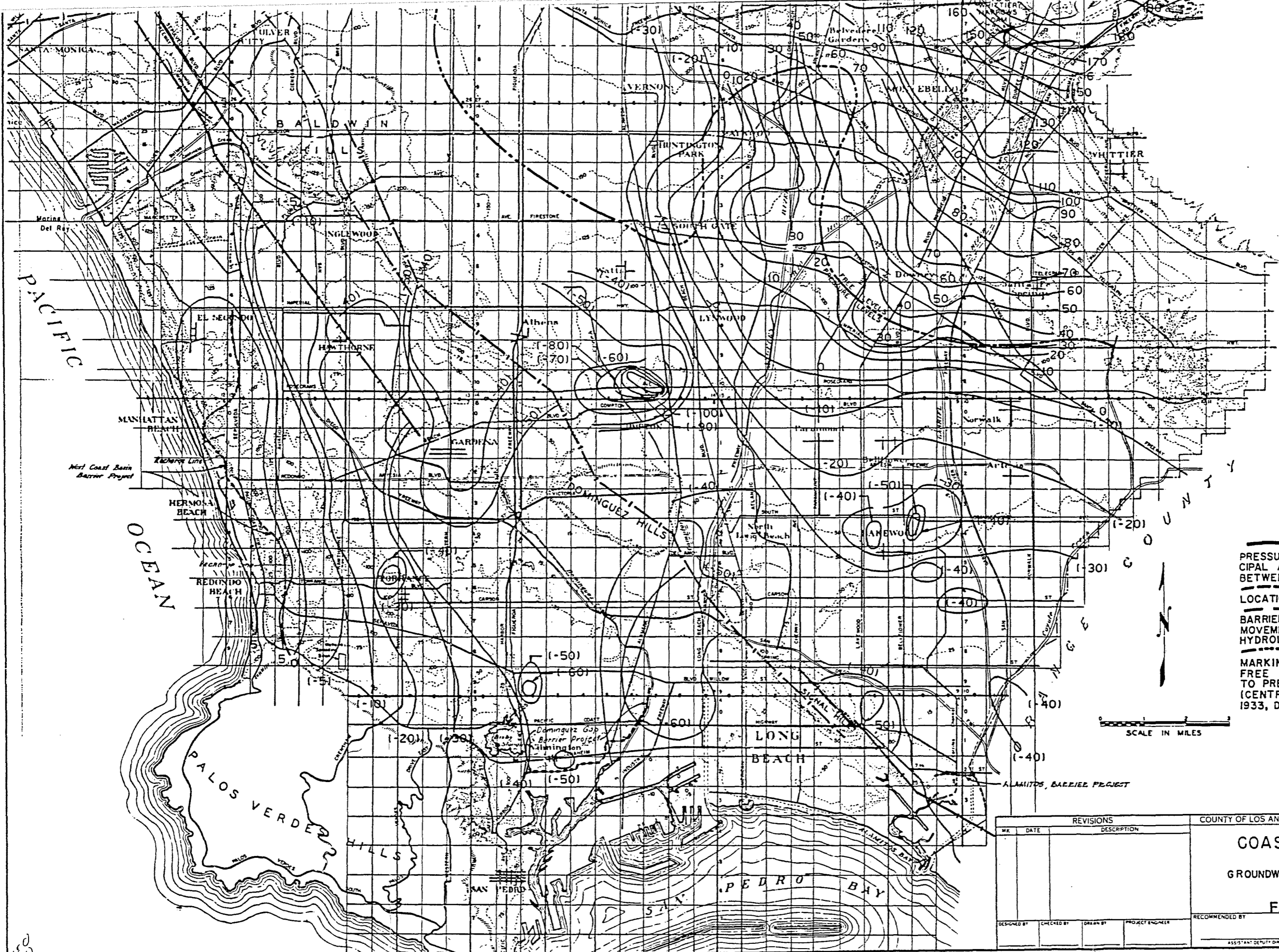

**EXPLANATION**

- LINES OF EQUAL PRESSURE ELEVATIONS- PRINCIPAL AQUIFER (INTERPOLATED BETWEEN WELLS)
- - - SAME AS ABOVE, LOCATION APPROXIMATE.
- RESTRICTIONS OR BARRIERS TO GROUNDWATER MOVEMENT, (GEOLOGIC AND/OR HYDROLOGIC)
- - - LINE APPROXIMATELY MARKING TRANSITION FROM FREE GROUNDWATER LEVELS TO PRESSURE LEVELS. (CENTRAL COASTAL PLAIN 1933, D.W.R. BULL. NO. 45.)

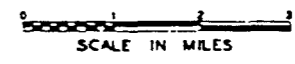

REVISIONS		COUNTY OF LOS ANGELES DEPARTMENT OF PUBLIC WORKS	
NO.	DATE	DESCRIPTION	
DESIGNED BY		PROJECT ENGINEER	
CHECKED BY		RECOMMENDED BY	
DRAWN BY		DATE	
		SCALE	
		NO. 2-H291	
		SHEET OF	

**COASTAL PLAIN  
DEEP AQUIFER  
GROUNDWATER CONTOUR MAP  
FOR  
FALL 1994**





**EXPLANATION**

- LINES OF EQUAL PRESSURE ELEVATIONS - PRINCIPAL AQUIFER (INTERPOLATED BETWEEN WELLS)
- - - - SAME AS ABOVE, LOCATION APPROXIMATE.
- RESTRICTIONS OR BARRIERS TO GROUNDWATER MOVEMENT, (GEOLOGIC AND/OR HYDROLOGIC)
- - - - LINE APPROXIMATELY MARKING TRANSITION FROM FREE GROUNDWATER LEVELS TO PRESSURE LEVELS. (CENTRAL COASTAL PLAIN 1933, D.W.R. BULL. NO. 45.)

SCALE IN MILES

REVISIONS				COUNTY OF LOS ANGELES DEPARTMENT OF PUBLIC WORKS	
NO.	DATE	DESCRIPTION	DESIGNED BY	CHECKED BY	PROJECT ENGINEER

  

<b>COASTAL PLAIN DEEP AQUIFER GROUNDWATER CONTOUR MAP FOR FALL 1995</b>		
RECOMMENDED BY	DATE	SCALE
ASSISTANT COUNTY DIRECTOR	NO.	SHEET OF

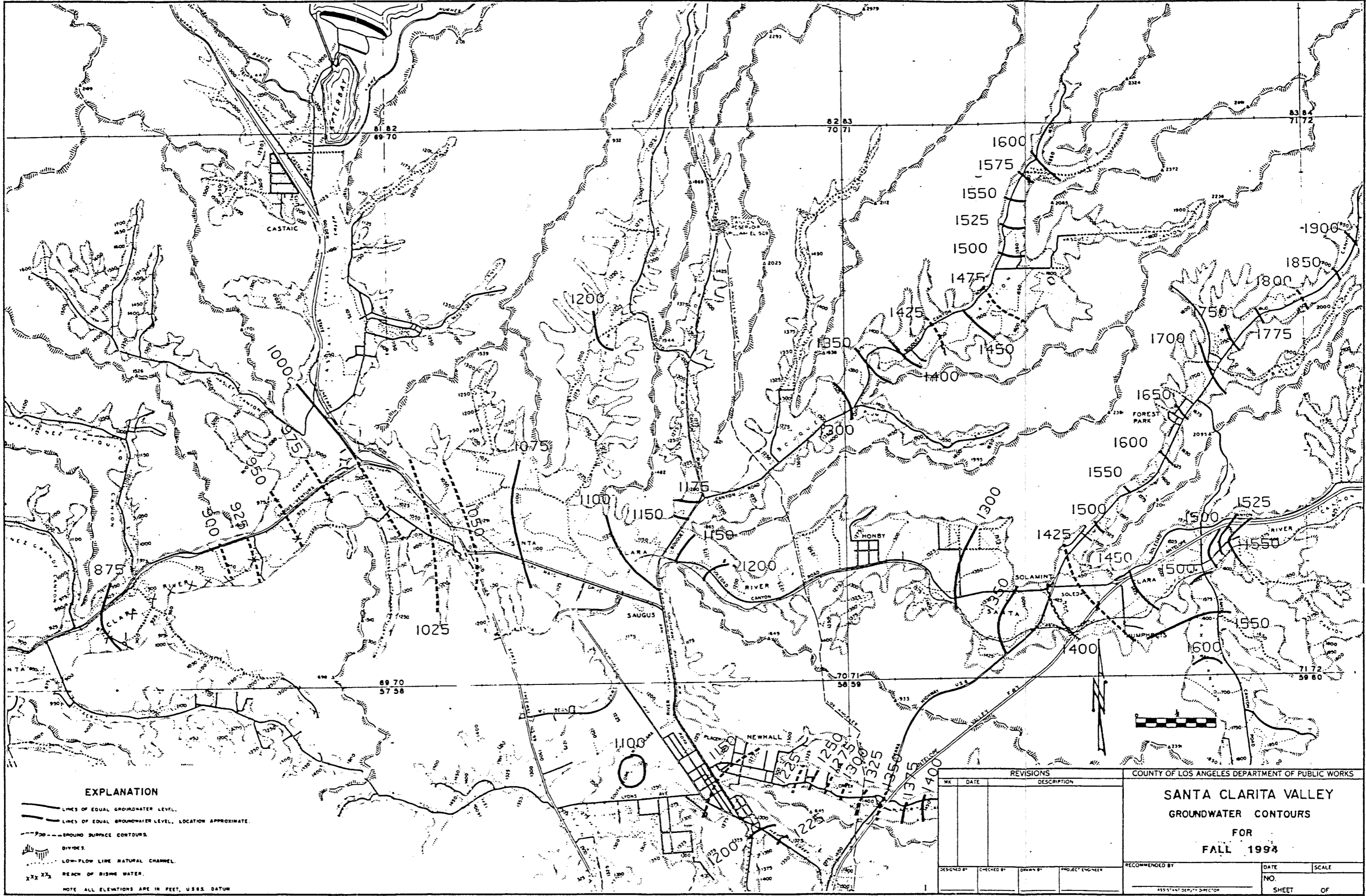

REVISIONS				COUNTY OF LOS ANGELES DEPARTMENT OF PUBLIC WORKS			
NO.	DATE	DESCRIPTION	DESIGNED BY	CHECKED BY	DRAWN BY	PROJECT ENGINEER	RECOMMENDED BY
<p align="center"><b>SANTA CLARITA VALLEY GROUNDWATER CONTOURS FOR FALL 1994</b></p>							<p>DATE _____</p> <p>SCALE _____</p>
<p>DESIGNED BY _____ CHECKED BY _____ DRAWN BY _____ PROJECT ENGINEER _____</p>							<p>RECOMMENDED BY _____</p> <p>ASSISTANT DEPUTY DIRECTOR</p>
<p>NO. _____</p>							<p>SHEET _____ OF _____</p>



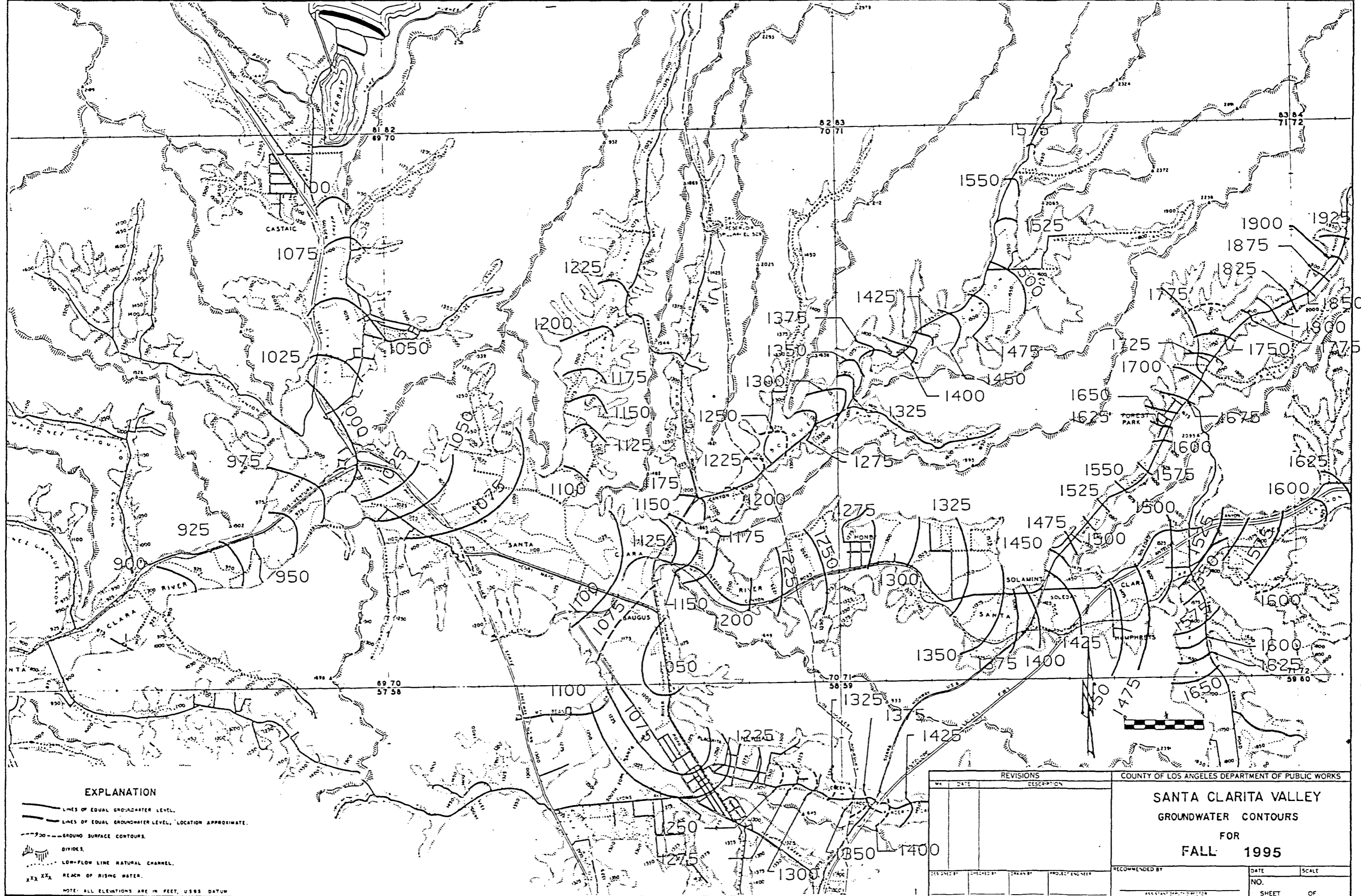

**EXPLANATION**

- LINES OF EQUAL GROUNDWATER LEVEL.
- - - LINES OF EQUAL GROUNDWATER LEVEL, LOCATION APPROXIMATE.
- · · GROUND SURFACE CONTOURS.
- ▲ DIVIDES.
- - - LOW-FLOW LINE NATURAL CHANNEL.
- XX XX REACH OF RISING WATER.

NOTE: ALL ELEVATIONS ARE IN FEET, USNS DATUM

REVISIONS				COUNTY OF LOS ANGELES DEPARTMENT OF PUBLIC WORKS	
NO.	DATE	DESCRIPTION			

<b>SANTA CLARITA VALLEY GROUNDWATER CONTOURS FOR FALL 1995</b>		
RECOMMENDED BY	DATE	SCALE
	NO.	SHEET OF